

[54] **MOTORCYCLE**

[75] **Inventor:** Atsushi Ishiyama, Tokyo, Japan

[73] **Assignee:** Yamaha Hatsudoki Kabushiki Kaisha, Japan

[**] **Term:** 14 Years

[21] **Appl. No.:** 296,237

[22] **Filed:** Aug. 25, 1981

[30] **Foreign Application Priority Data**

Feb. 27, 1981 [JP] Japan 56-8202

[51] **Int. Cl.** D12-11

[52] **U.S. Cl.** D12/110

[58] **Field of Search** D12/110; 180/219

[56] **References Cited**

U.S. PATENT DOCUMENTS

D. 264,574 5/1982 Kurishima et al. D12/110

OTHER PUBLICATIONS

Cycle World, 6/80, Suzuki 1980 GS Model Brochure, GS 750 ET & GS-1100 ET.

Primary Examiner—James M. Gandy
Attorney, Agent, or Firm—Ostrolenk, Faber, Gerb & Soffen

[57] **CLAIM**

The ornamental design for a motorcycle, as shown.

DESCRIPTION

FIG. 1 is a right front perspective view of a motorcycle; FIG. 2 is a right side elevational view of a motorcycle; FIG. 3 is a left side elevational view of a motorcycle; FIG. 4 is a top plan view of a motorcycle; FIG. 5 is a front elevational view of a motorcycle; and FIG. 6 is a rear elevational view of a motorcycle.

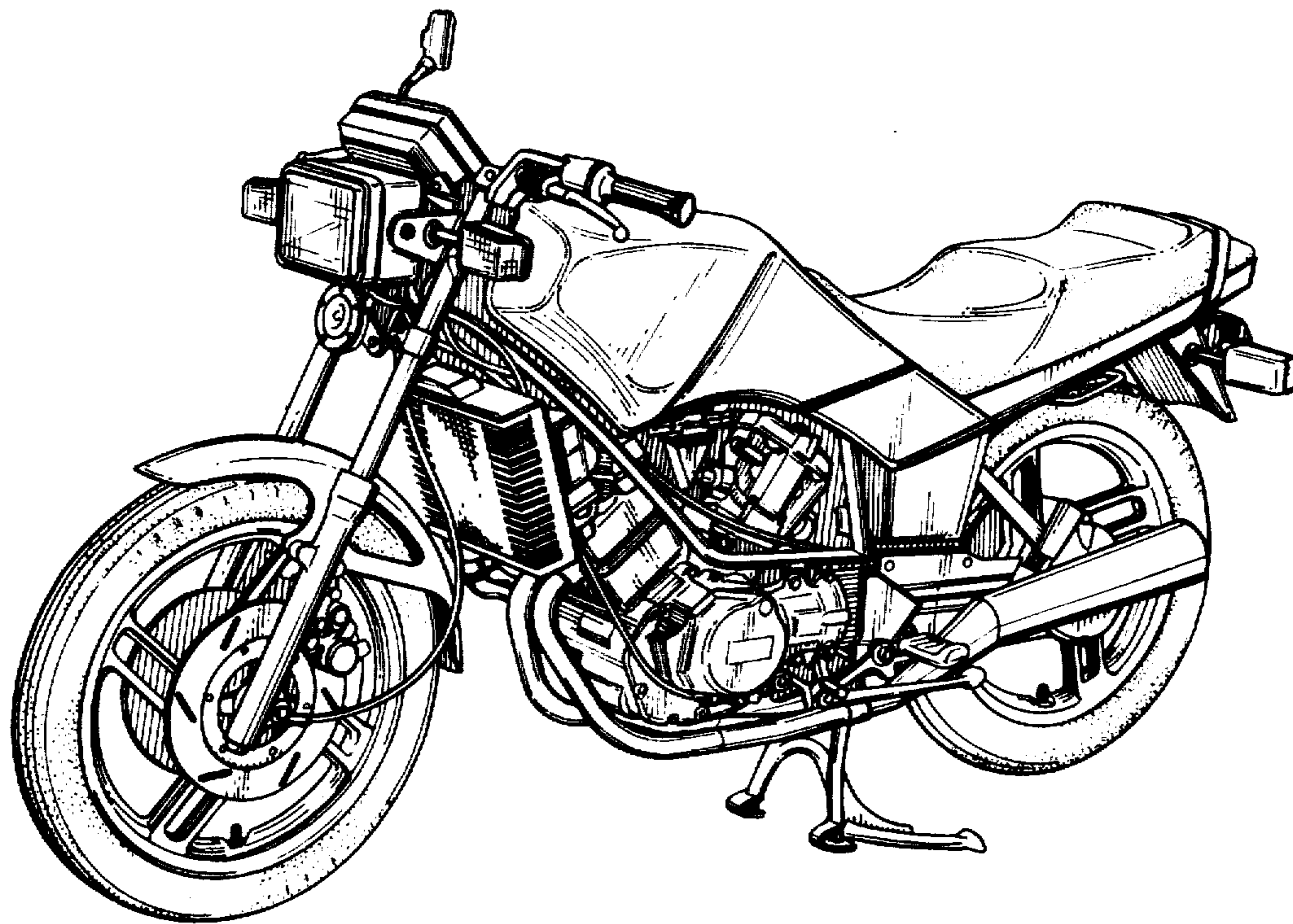

FIG. 1

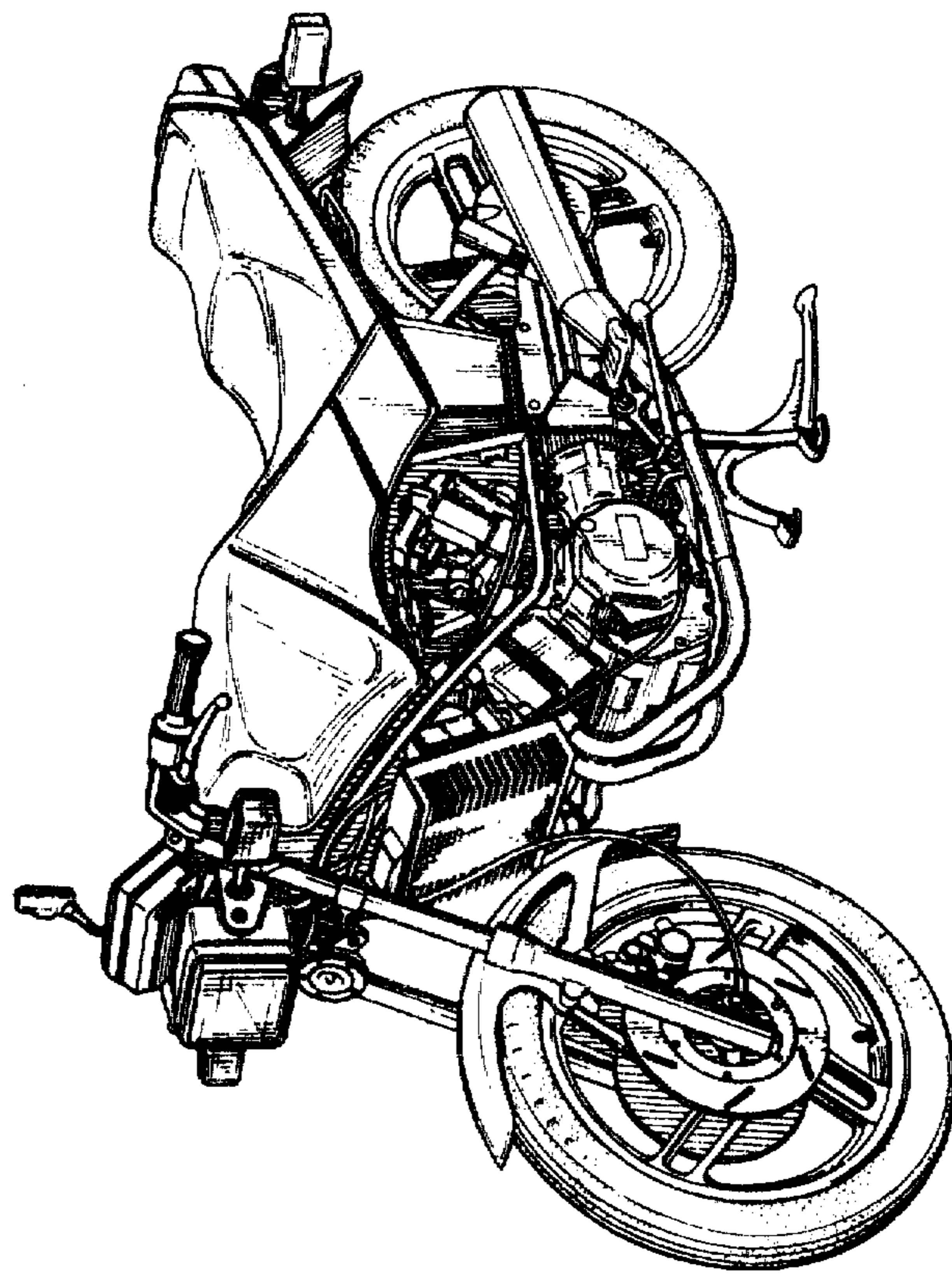

FIG.2

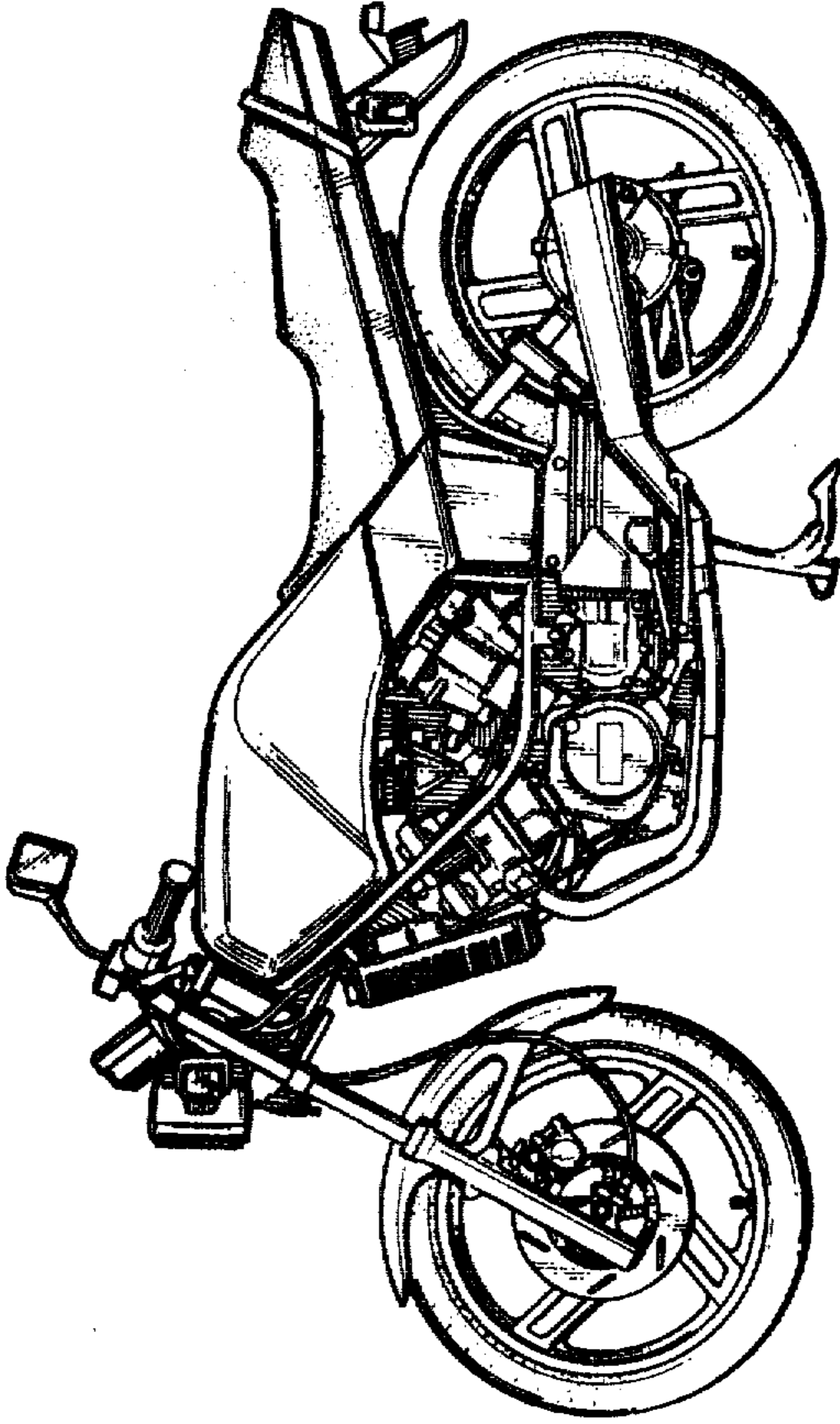

FIG.3

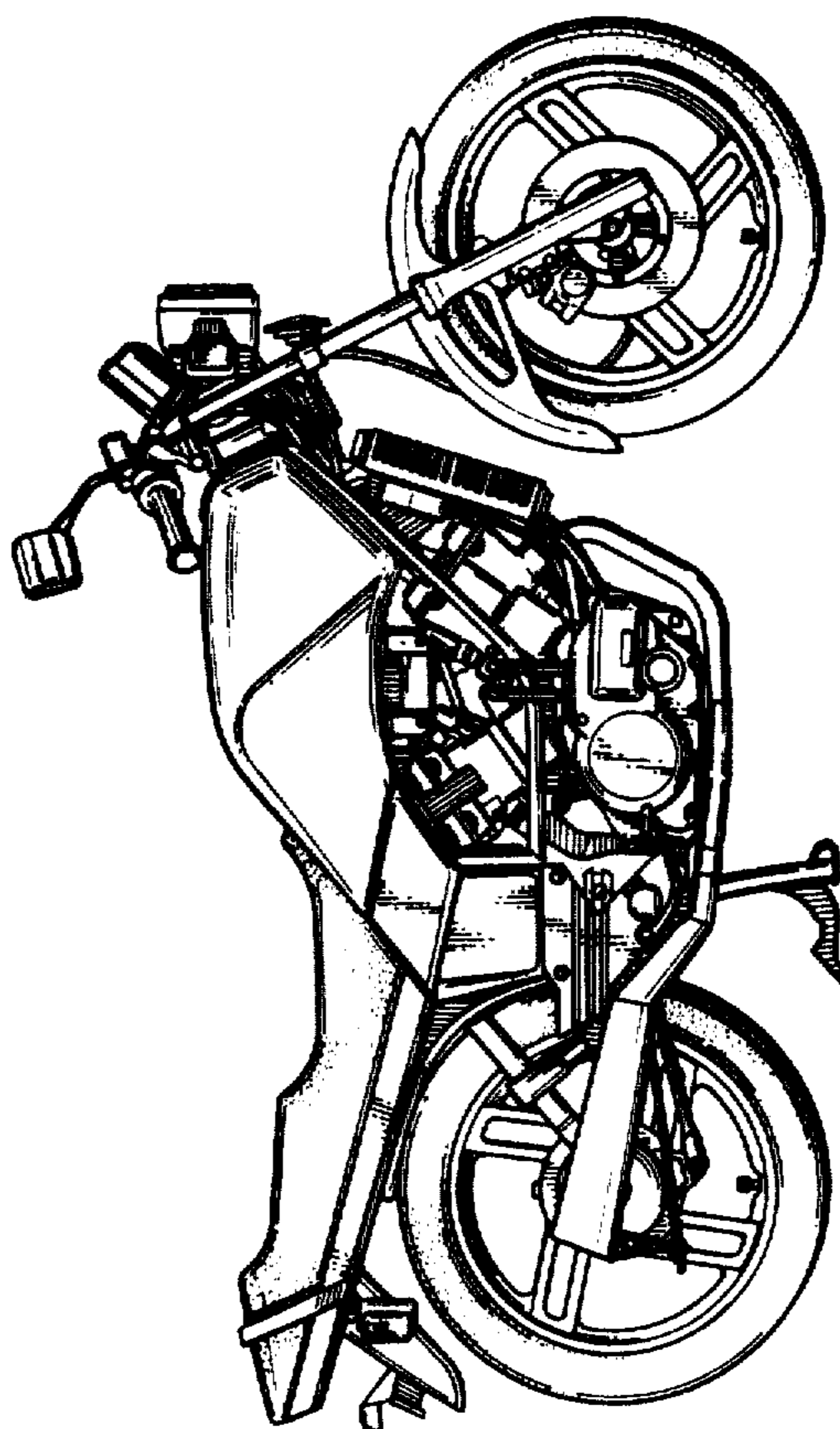

FIG.4

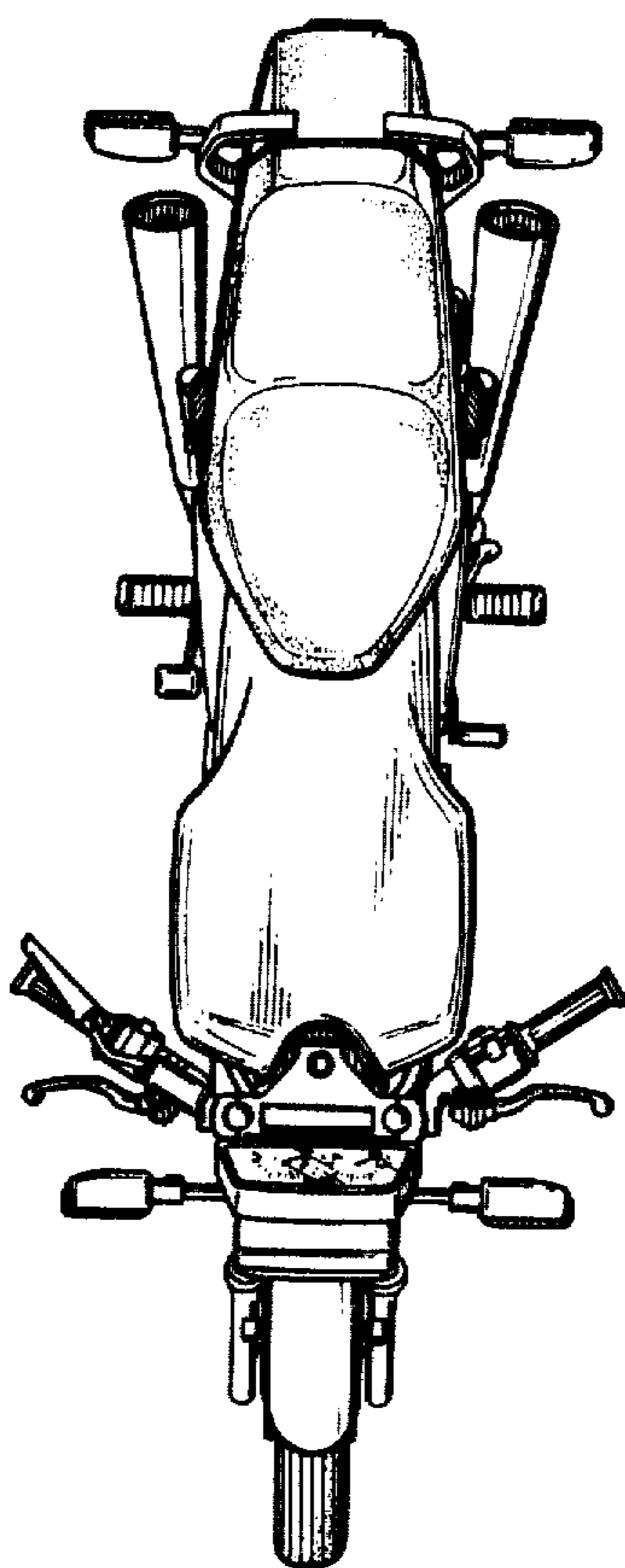

FIG.6

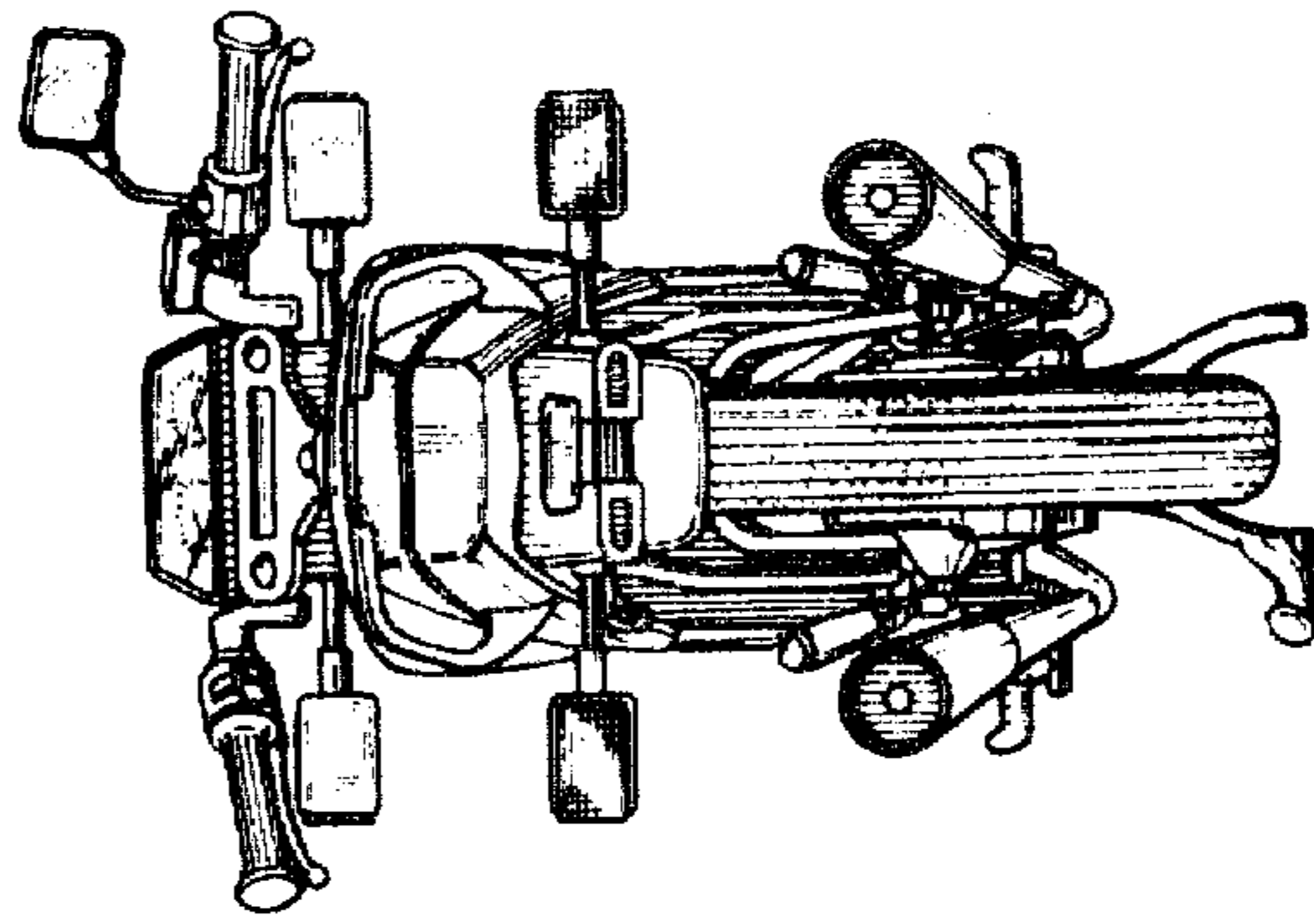

FIG.5

