

[54] QUICK HITCH FOR EARTH HANDLING TOOLS

[75] Inventor: Torsten Larsson, Karlskoga, Sweden

[73] Assignee: Aktiebolaget Bofors, Bofors, Sweden

[\*\*] Term: 14 Years

[21] Appl. No.: 315,117

[22] Filed: Oct. 26, 1981

[30] Foreign Application Priority Data

Apr. 27, 1981 [SE] Sweden ..... 81-1038

[51] Int. Cl. .... D15-03

[52] U.S. Cl. .... D15/28

[58] Field of Search ..... D15/10, 25, 28, 32; 172/439, 443, 248, 272; 280/456 A, 460 A, 461 A

[56] References Cited

U.S. PATENT DOCUMENTS

2,963,183	12/1960	Przybylski .....	414/723
3,874,533	4/1975	Montgomery et al. ....	172/272
3,935,953	2/1976	Stedman .....	172/272
4,204,794	5/1980	Aoshiba .....	172/272

Primary Examiner—Wallace R. Burke  
Assistant Examiner—Suzanne N. Gitlin  
Attorney, Agent, or Firm—Pollock, Vande Sande & Priddy

[57] CLAIM

The ornamental design for a quick hitch for earth handling tools, as shown and described.

DESCRIPTION

FIG. 1 is an oblique top right hand view of a quick hitch for earth handling tools embodying our new design; FIG. 2 is an oblique top left hand view thereof; and FIG. 3 is an oblique bottom right hand view thereof.

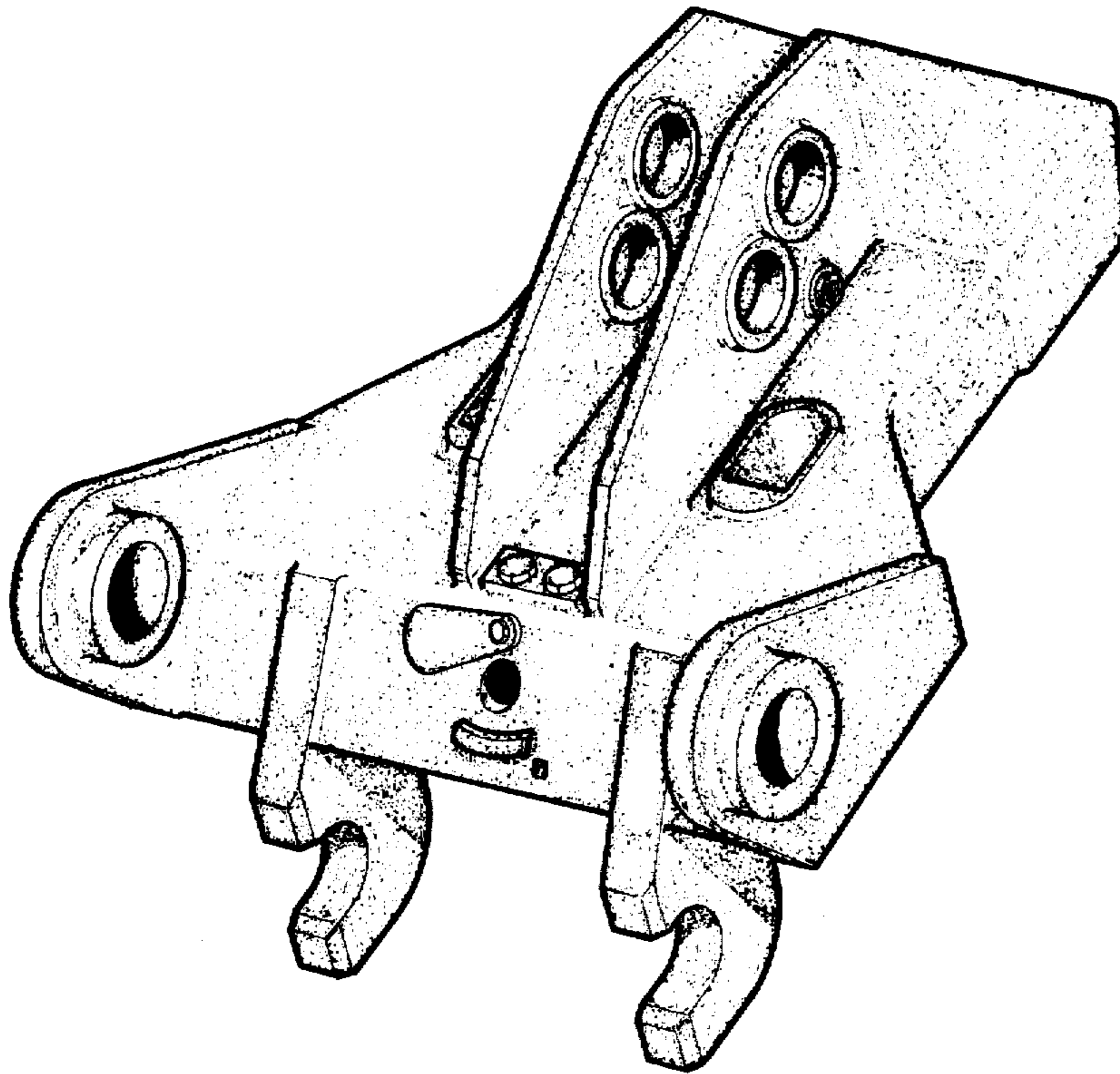

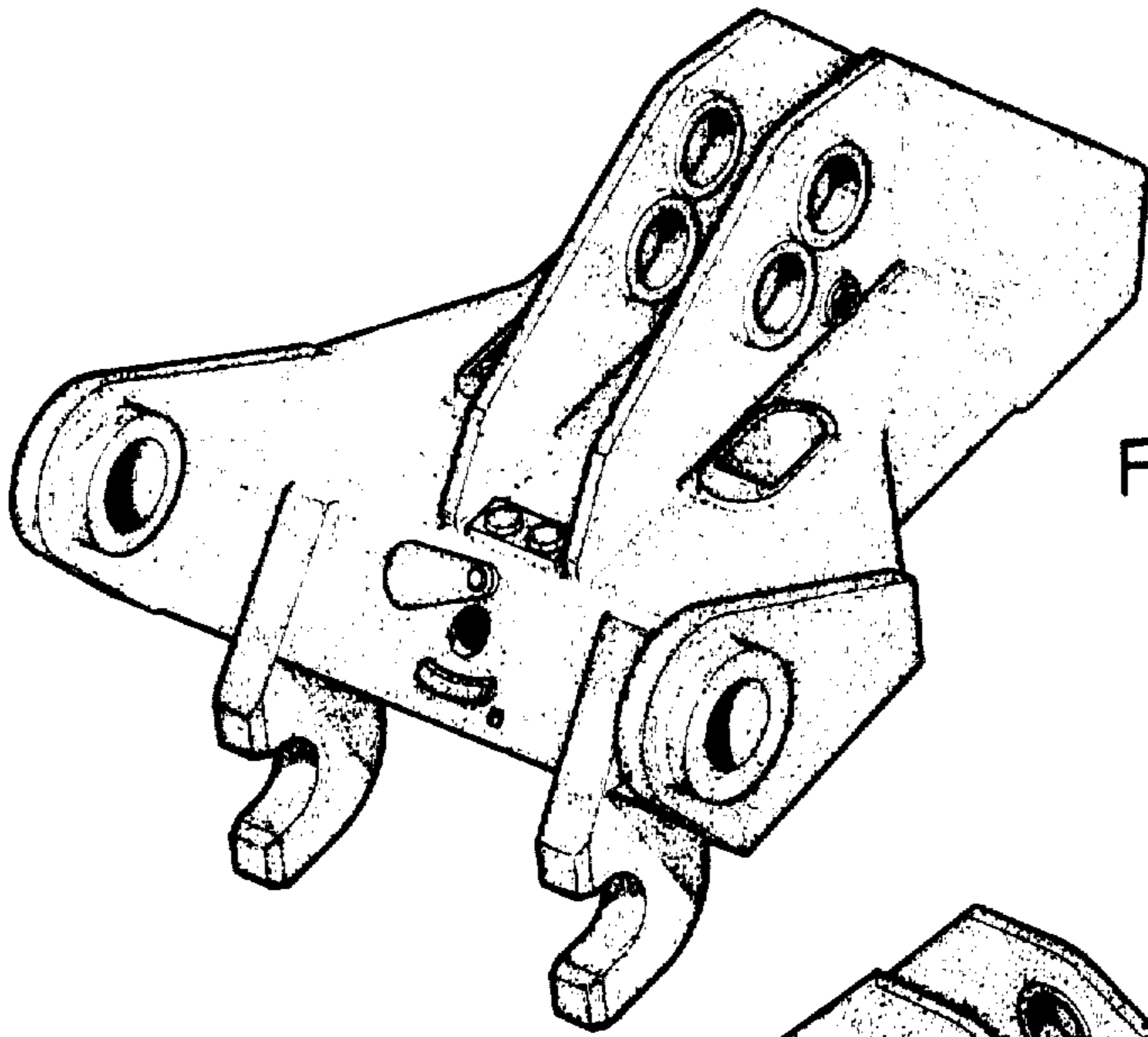

FIG. 1

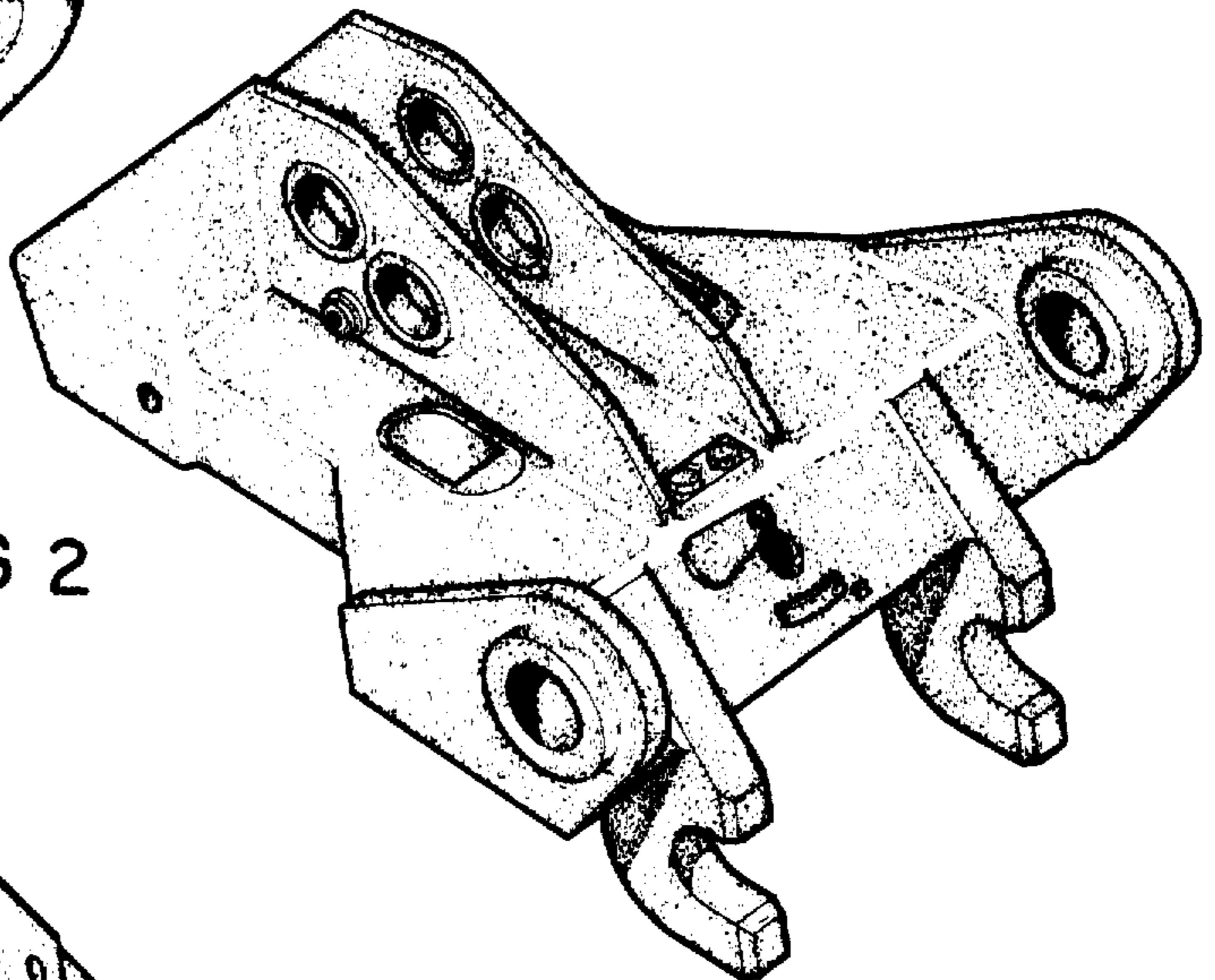

FIG 2

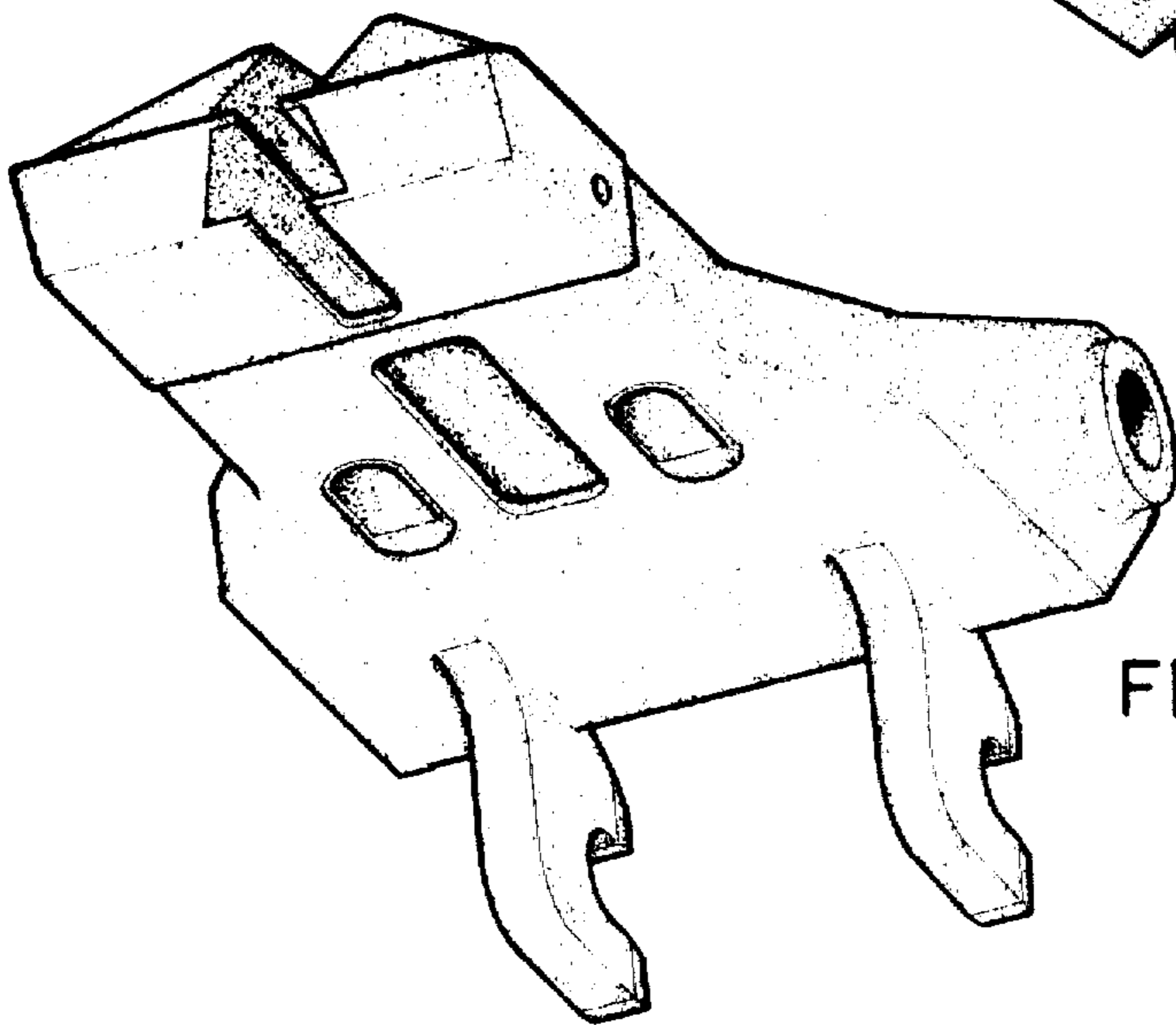

FIG. 3