

[54] **FRONT SHIELD FOR A MOTOR VEHICLE**

[75] **Inventor:** Jun Ito, Tokyo, Japan

[73] **Assignee:** Honda Giken Kogyo Kabushiki Kaisha, Tokyo, Japan

[**] **Term:** 14 Years

[21] **Appl. No.:** 277,507

[22] **Filed:** Jun. 26, 1981

[30] **Foreign Application Priority Data**

Dec. 26, 1980 [JP] Japan 55-54961

[51] **Int. Cl.** **D12-11**

[52] **U.S. Cl.** **D12/182**

[58] **Field of Search** D12/182; 296/78.1

[56] **References Cited**

U.S. PATENT DOCUMENTS

D. 257,838 1/1981 Mockett D12/182

OTHER PUBLICATIONS

Cycle World, 2/80, p. 106, Bates Fairing, top of page. Cycle, 6/79, p. 59, Moto Guzzi Fairing.

Primary Examiner—James M. Gandy
Attorney, Agent, or Firm—Sughrue, Mion, Zinn, Macpeak & Seas

[57] **CLAIM**

The ornamental design for a front shield for a motor vehicle, as shown and described.

DESCRIPTION

FIG. 1 is a perspective view of a front shield for a motor vehicle showing my new design; FIG. 2 is a front elevational view thereof; FIG. 3 is a top plan view thereof; FIG. 4 is a side elevational view of the other side thereof; FIG. 5 is a rear elevational view thereof; and FIG. 6 is a bottom plan view thereof.

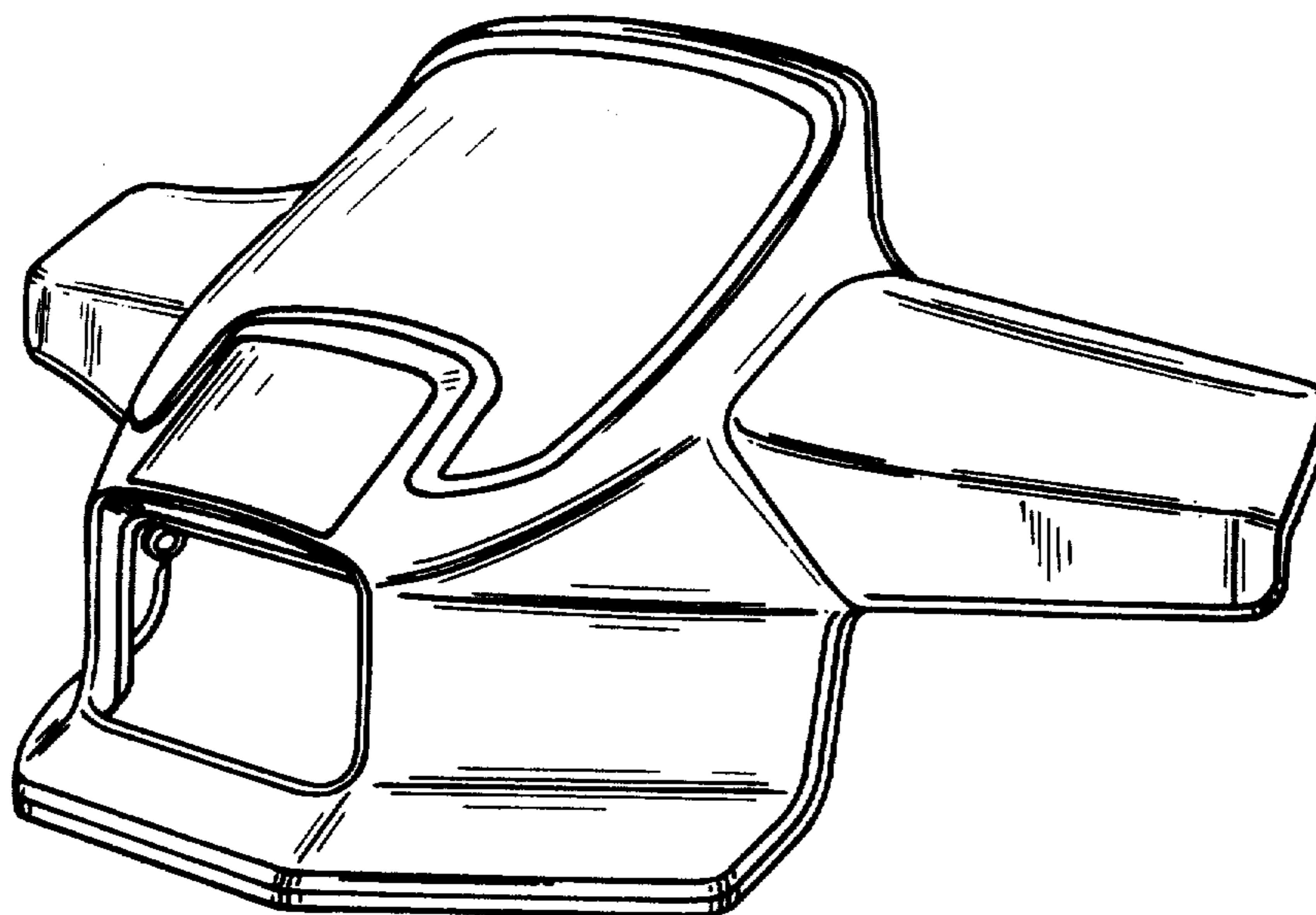

FIG. 1

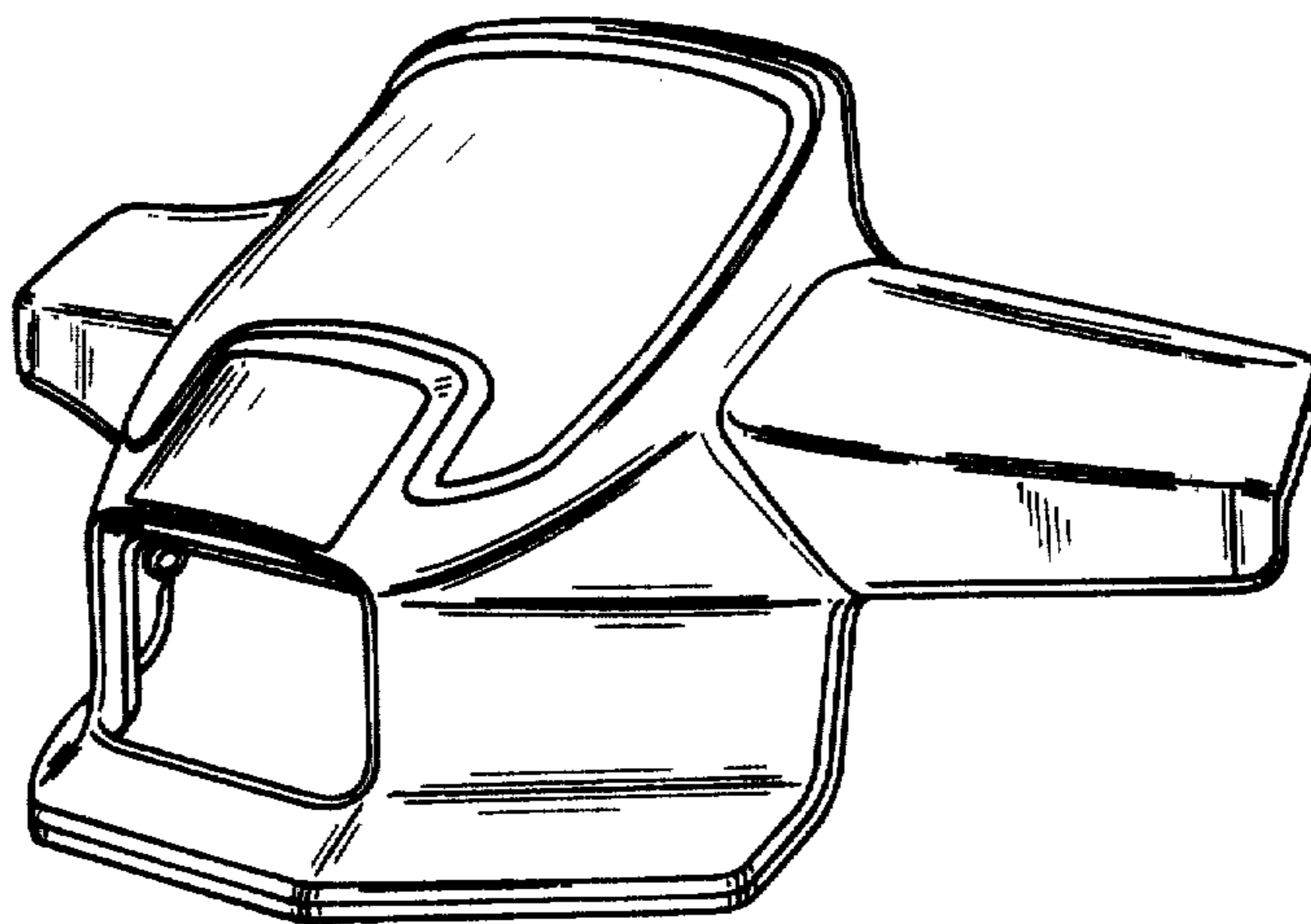

FIG. 2

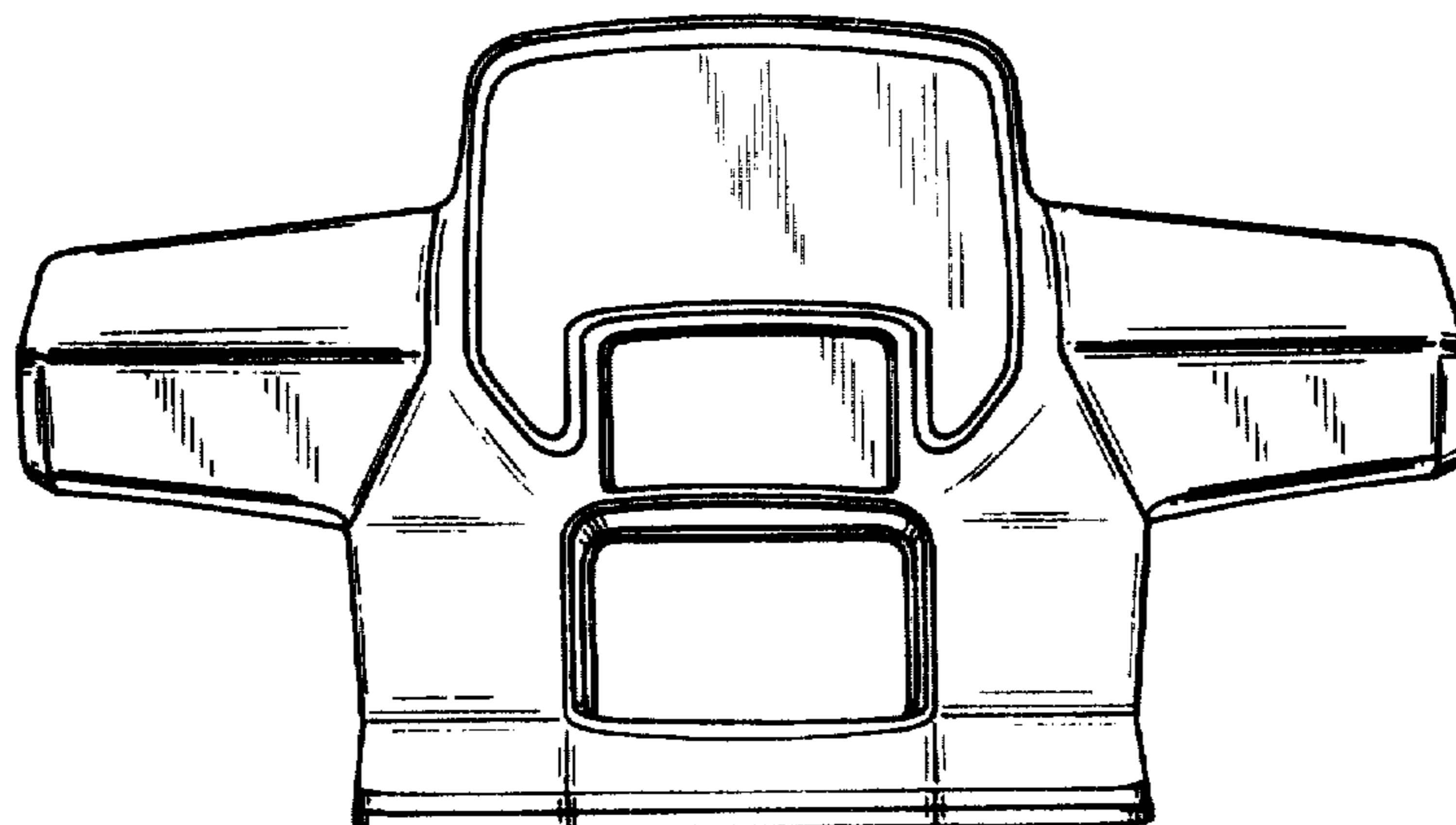

FIG. 3

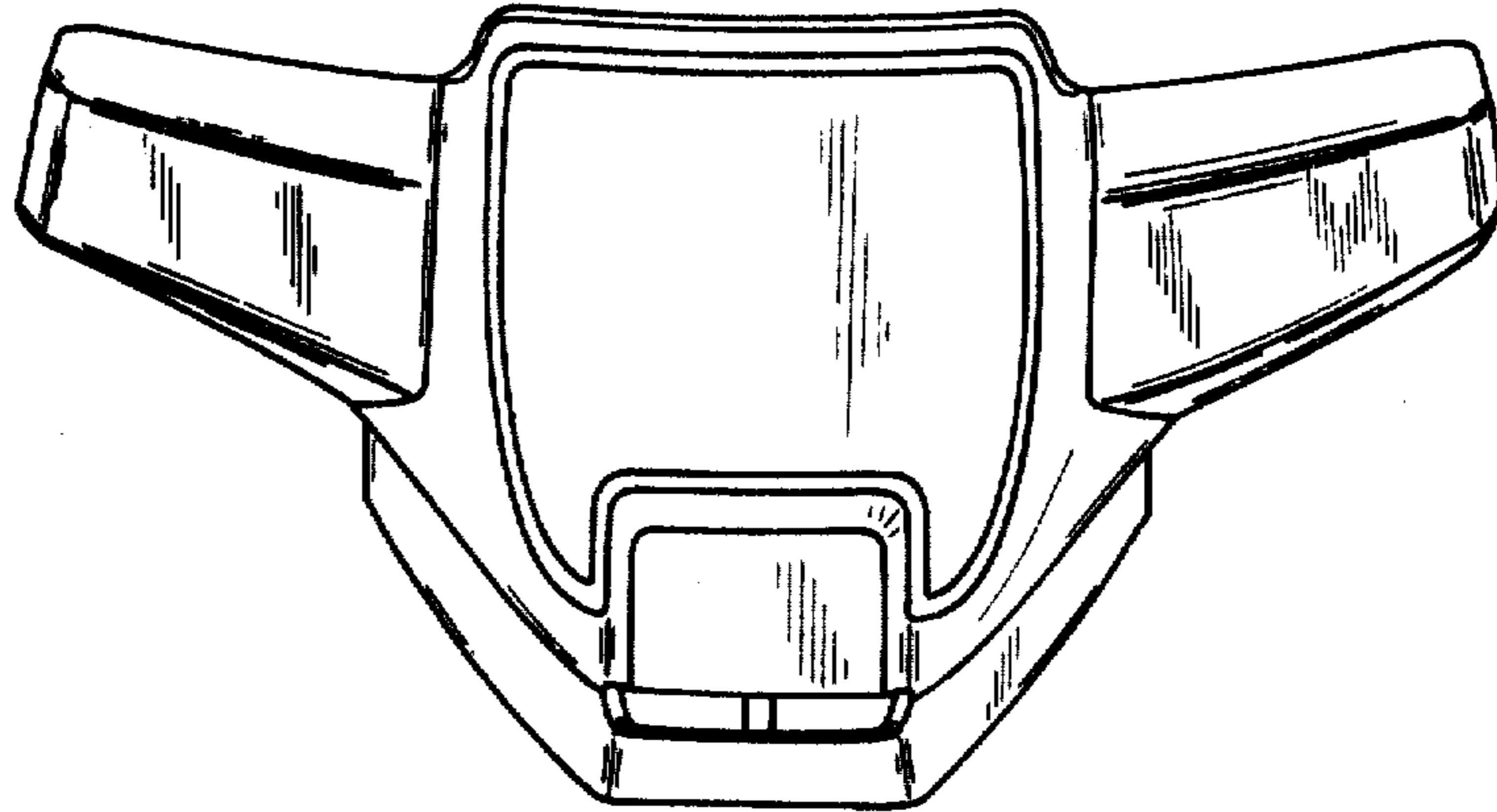

FIG. 4

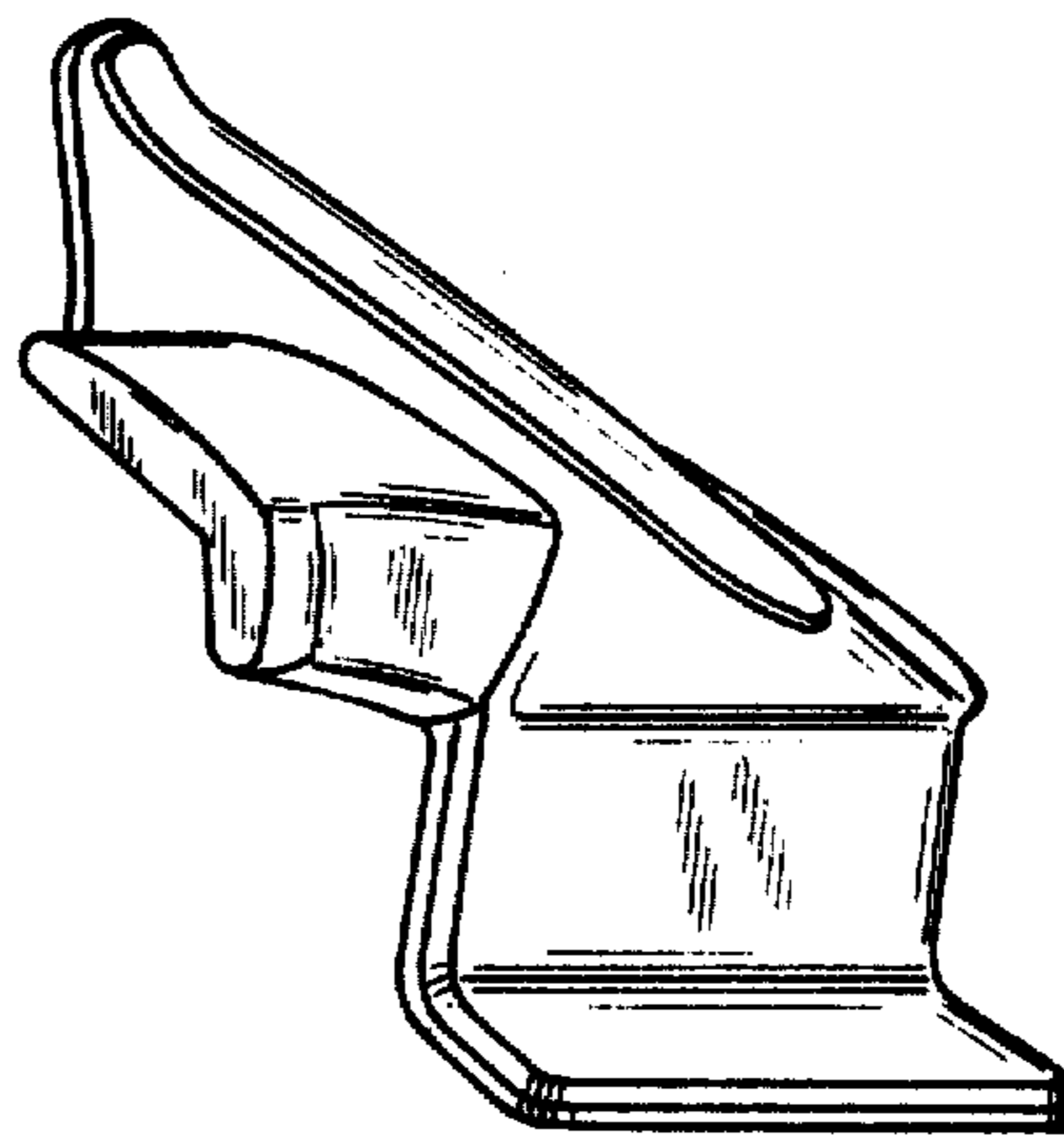

FIG. 5

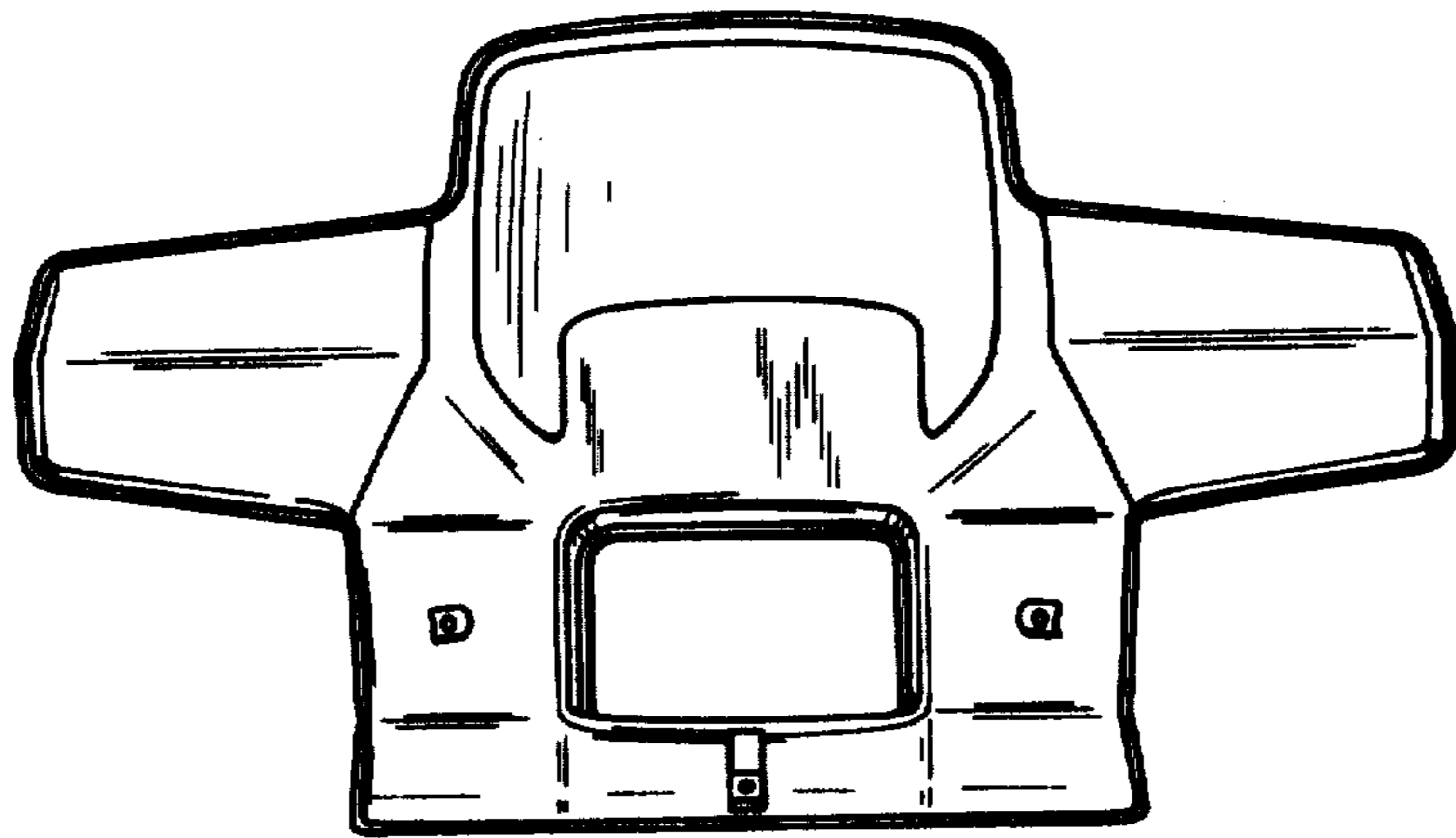

FIG. 6

