

[54] MOTORCYCLE BACKREST

[76] Inventor: Bernard Danielson, 12007 Hwy. 55, Minneapolis, Minn. 55441

[**] Term: 14 Years

[21] Appl. No.: 314,031

[22] Filed: Oct. 22, 1981

[51] Int. Cl. D12-11

[52] U.S. Cl. D12/119; D12/158

[58] Field of Search D12/119, 158; D6/197; 297/DIG. 9, 352, 383; 224/32 A, 39

[56] References Cited

U.S. PATENT DOCUMENTS

D. 255,561 6/1980 Pold et al. D12/158

OTHER PUBLICATIONS

J. C. Whitney Motorcycle Parts & Accessories Catalog No. 10A, ©1975, p. 24, Backrest & Carrier, bottom of page.

Cycle World, 5/80, p. 60, Backrest of Suzuki GS850, top of page.

Primary Examiner—James M. Gandy

Attorney, Agent, or Firm—Barnes & Thornburg

[57] CLAIM

The ornamental design for a motorcycle backrest, substantially as shown and described.

DESCRIPTION

FIG. 1 is a front perspective of a motorcycle backrest showing my new design;

FIG. 2 is a side elevational view thereof on a reduced scale it being understood that the broken lines are for illustrative purposes only;

FIG. 3 is a top plan view thereof on a reduced scale;

FIG. 4 is a front perspective view of a motorcycle backrest showing a second embodiment of my new design the sole difference being in the addition of a luggage rack;

FIG. 5 is a side elevational view of the embodiment shown in FIG. 4 on a reduced scale it being understood that the broken lines are for illustrative purposes only;

FIG. 6 is a top plan view of the embodiment shown in FIG. 4 on a reduced scale;

FIG. 7 is a front perspective view of a motorcycle backrest showing a third embodiment of my new design; the differences being in the addition of a luggage rack and outriggers;

FIG. 8 is a front perspective view of motorcycle backrest showing a fourth embodiment of my new design, the differences being in the addition of a luggage rack and outriggers; and

FIG. 9 is a front perspective view of a motorcycle backrest showing a fifth embodiment of my new design; the sole difference being in the addition of outriggers.

The rear surface of the backrest pad is understood to be flat and unornamented.

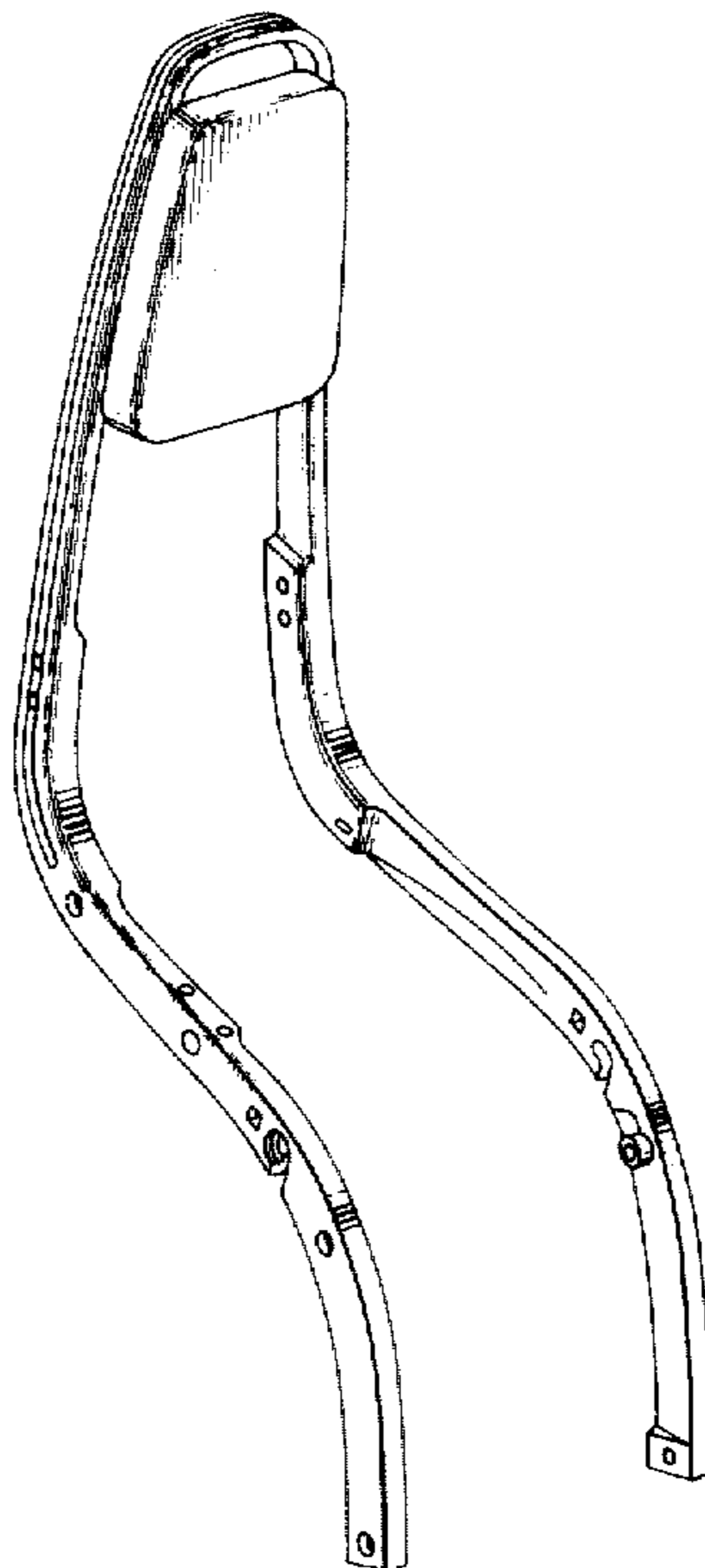

FIG. 1.

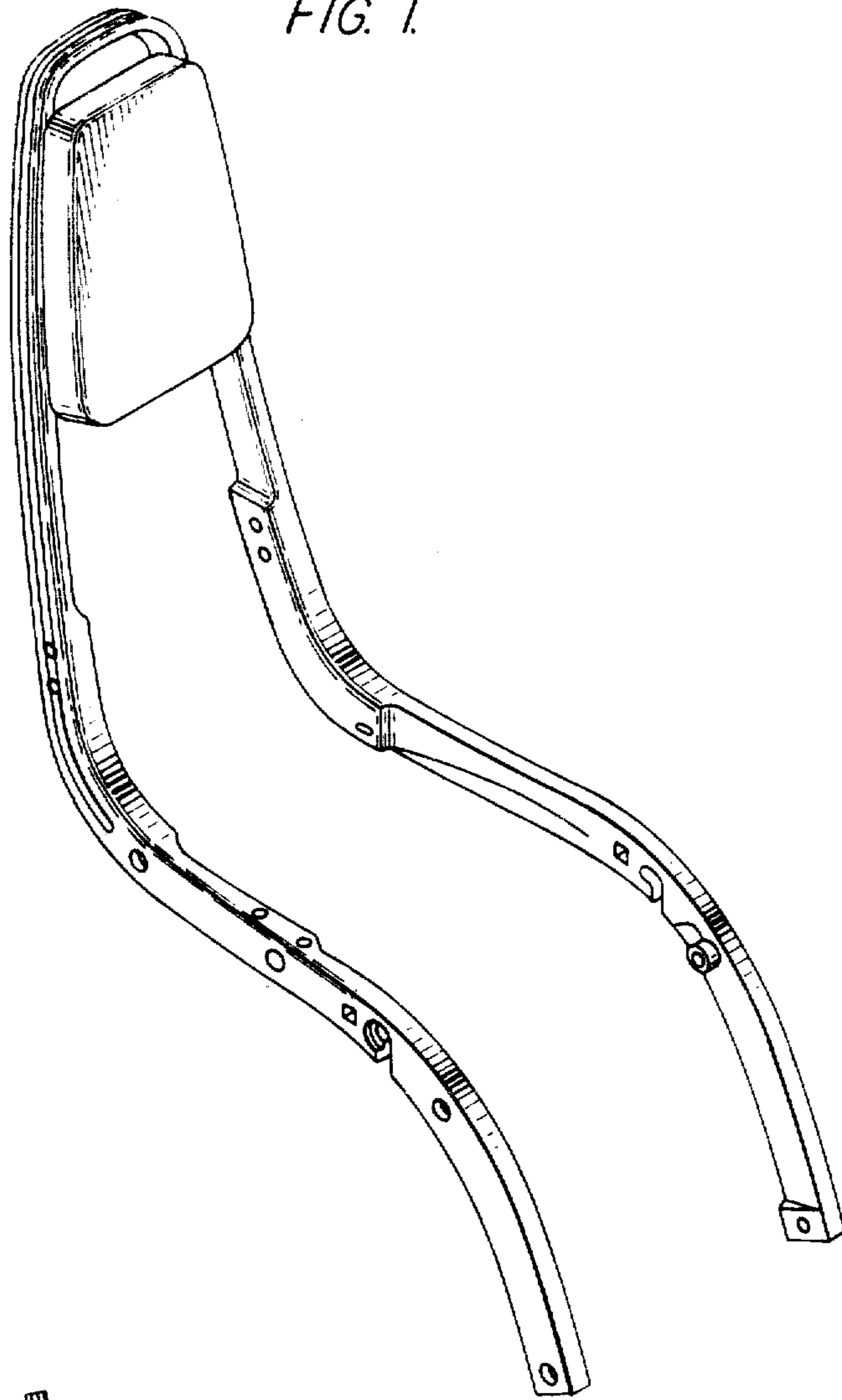

FIG. 3.

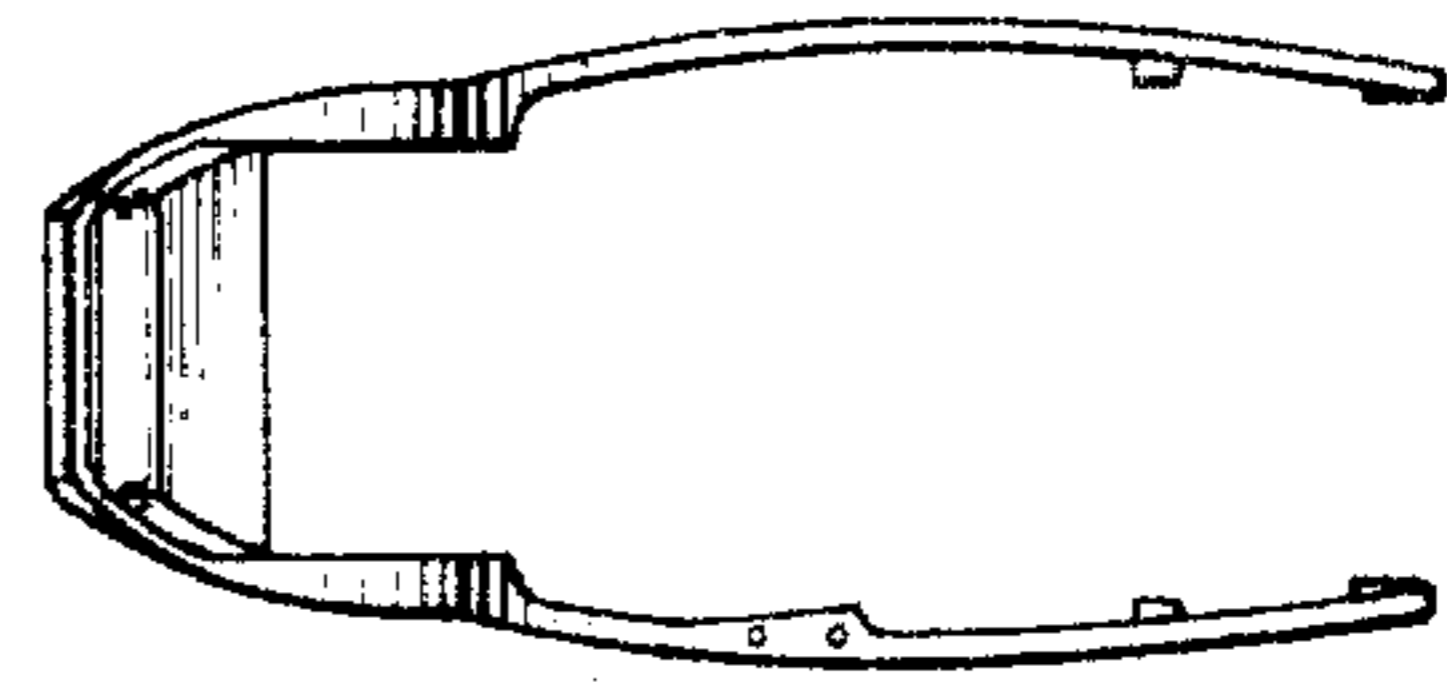
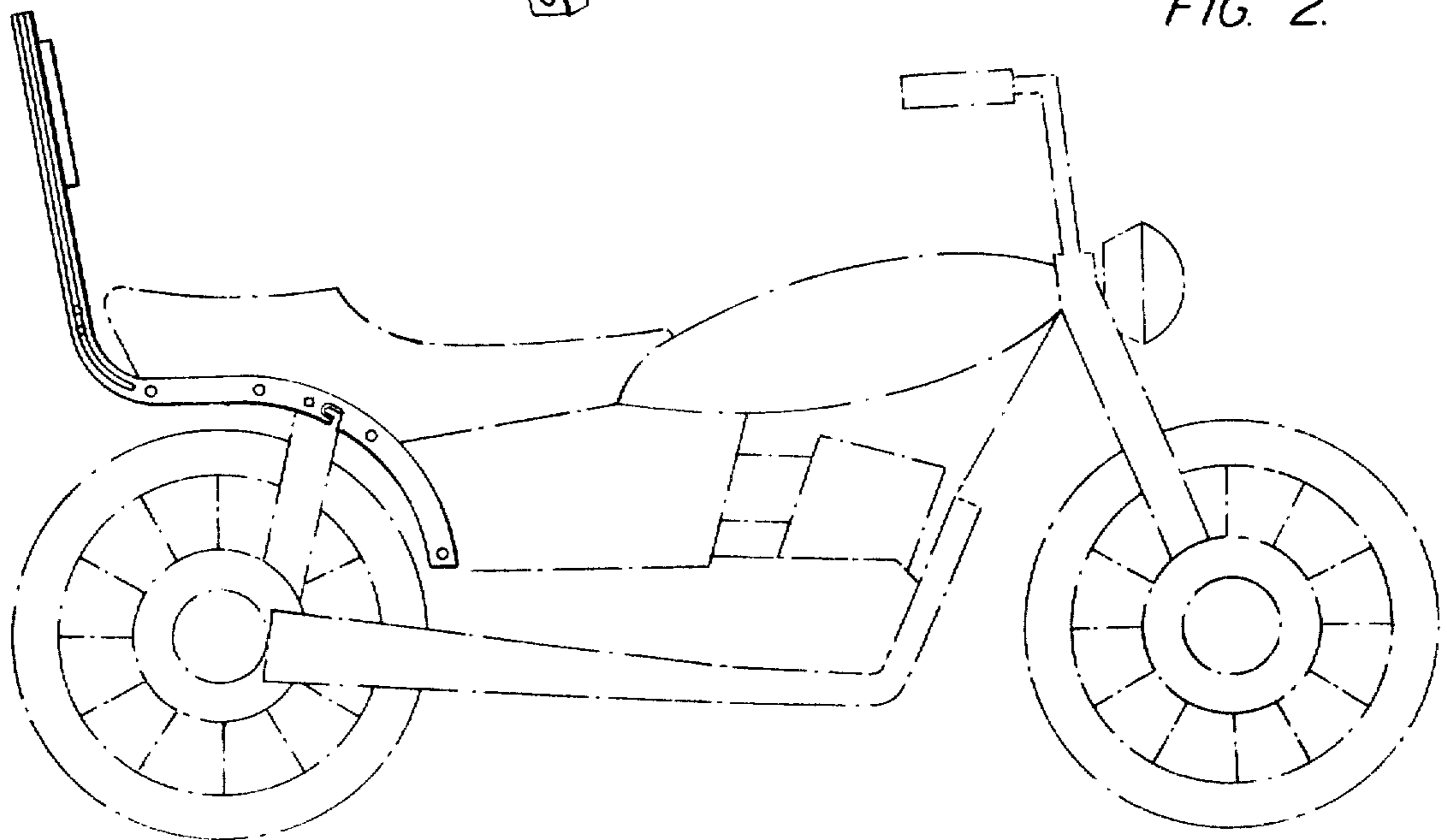

FIG. 2.



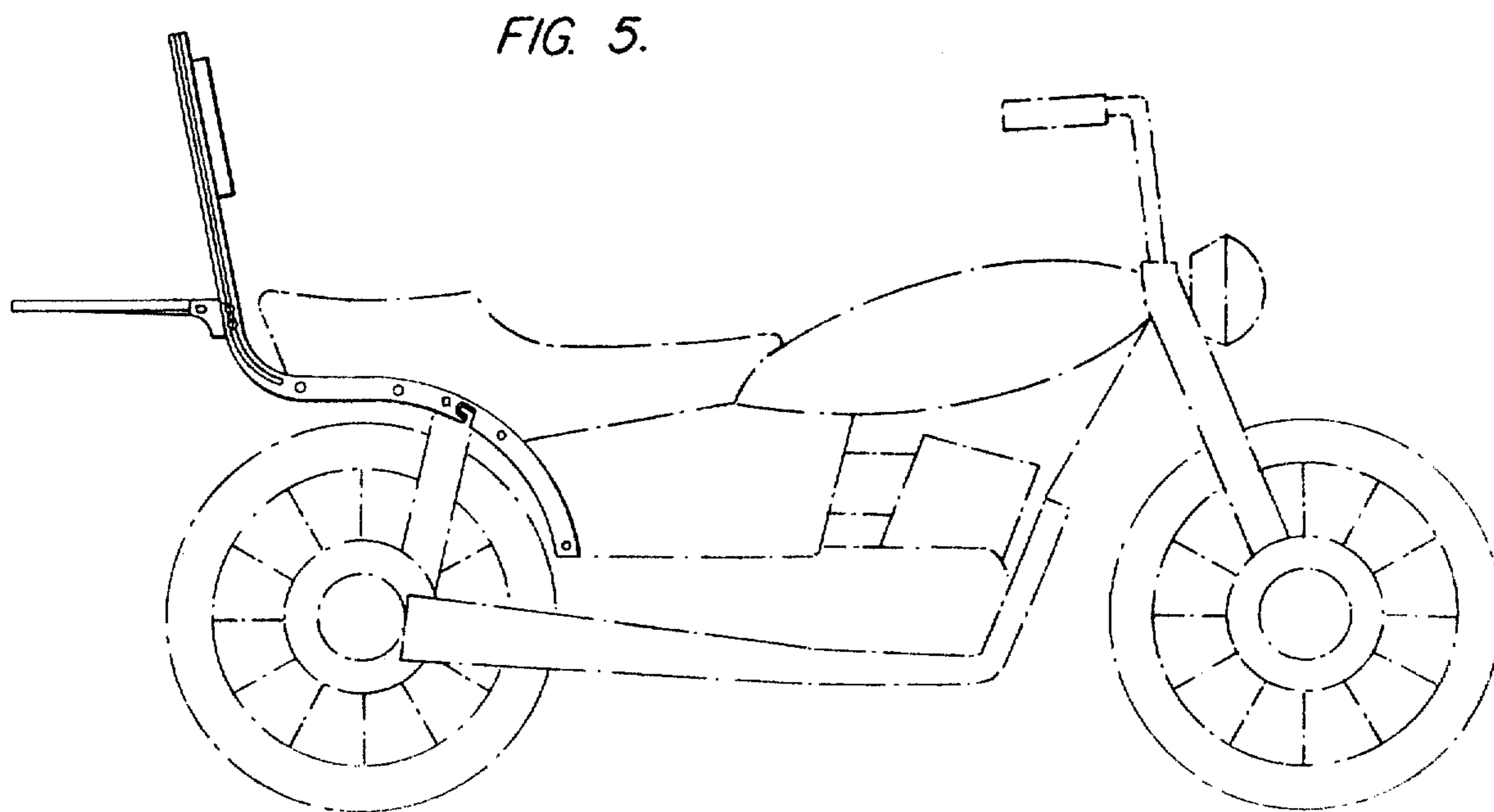
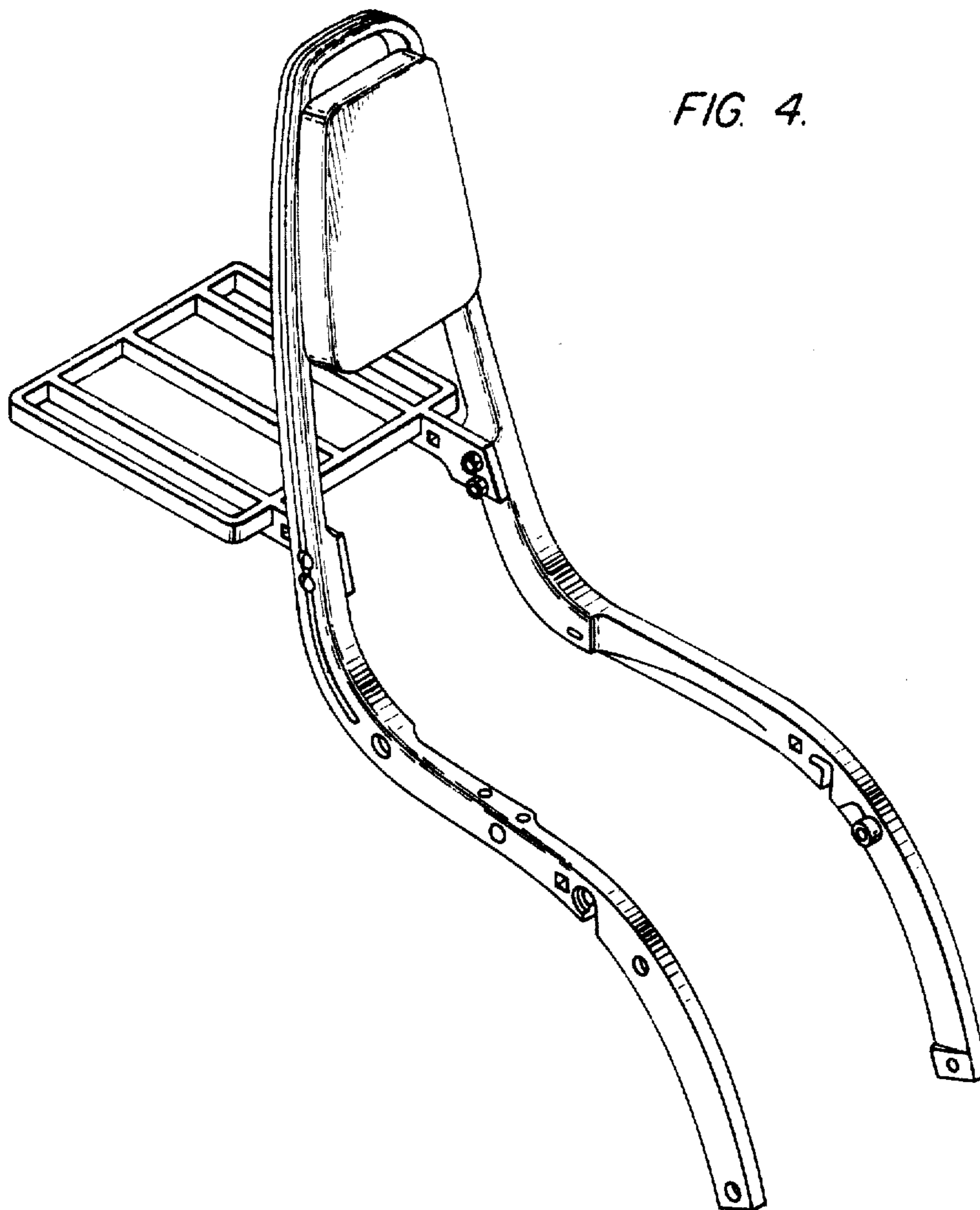

FIG. 6.

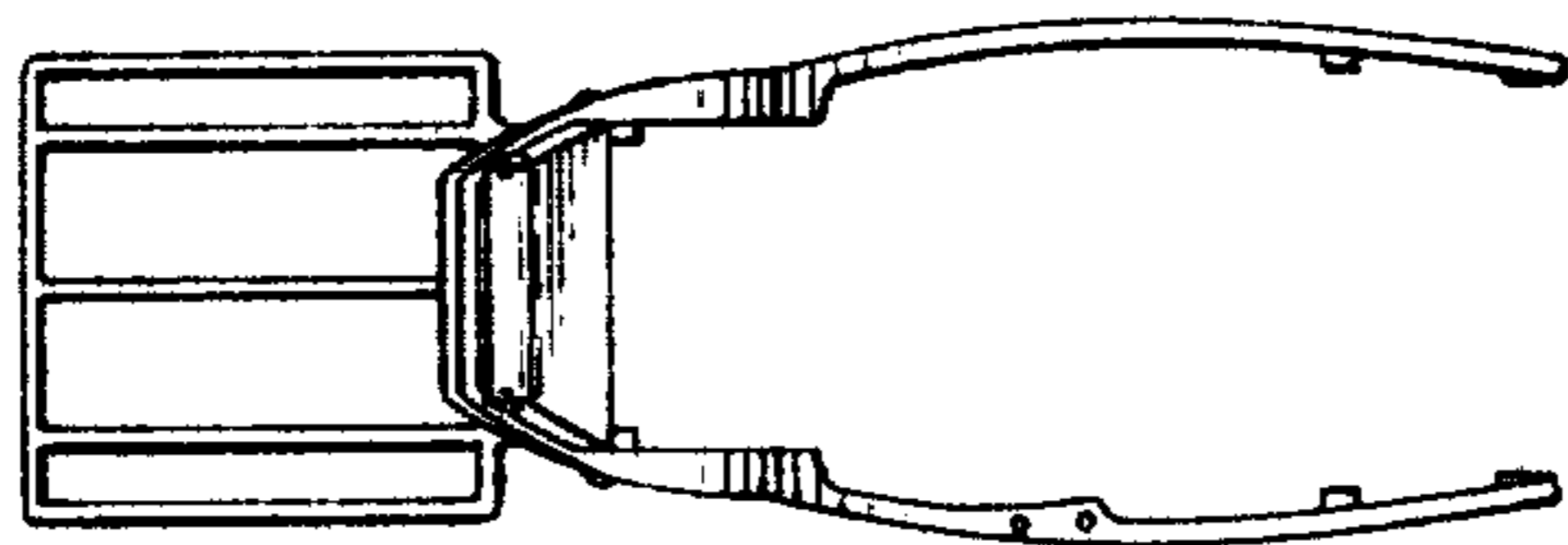

FIG. 7.

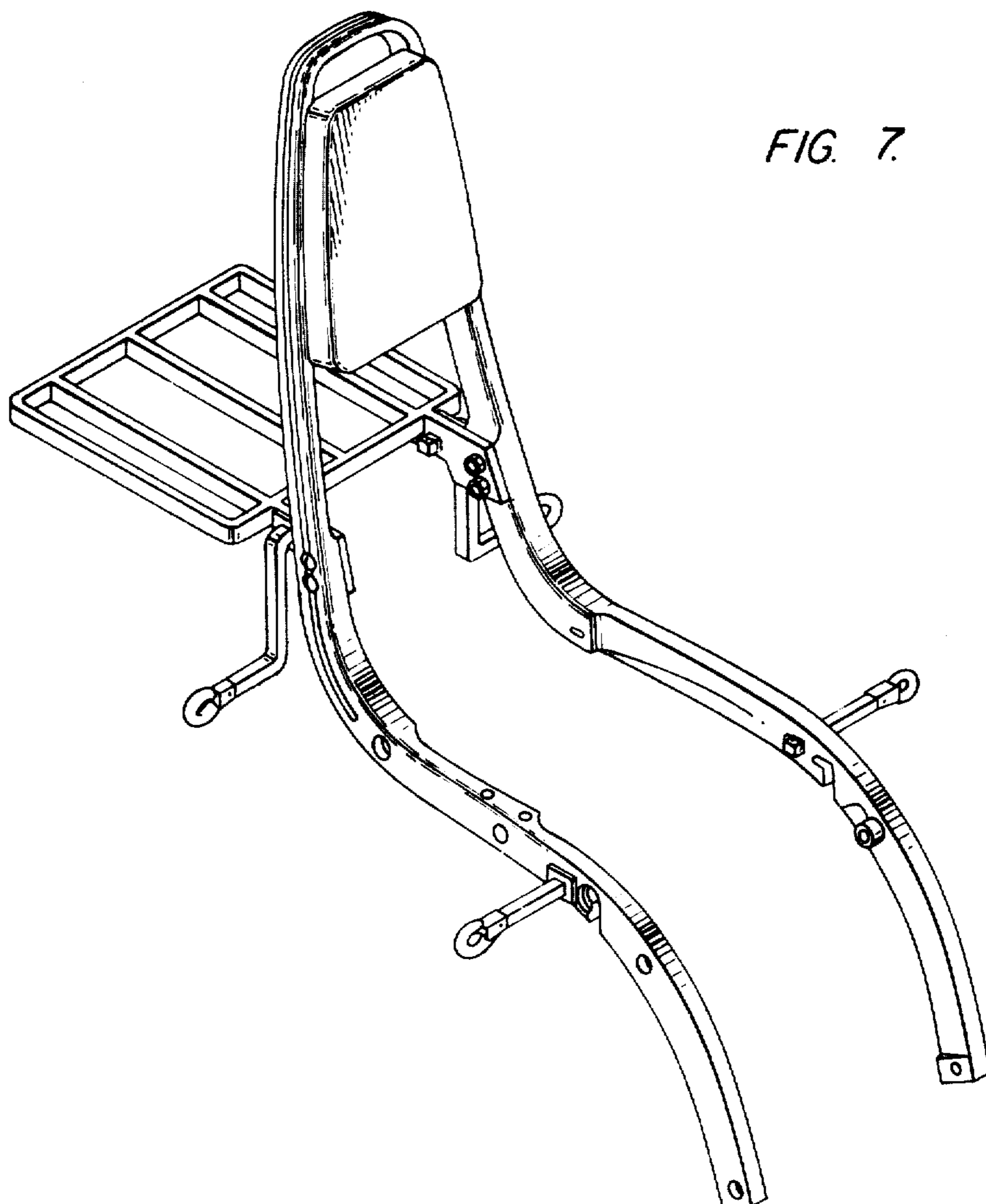

FIG. 9.

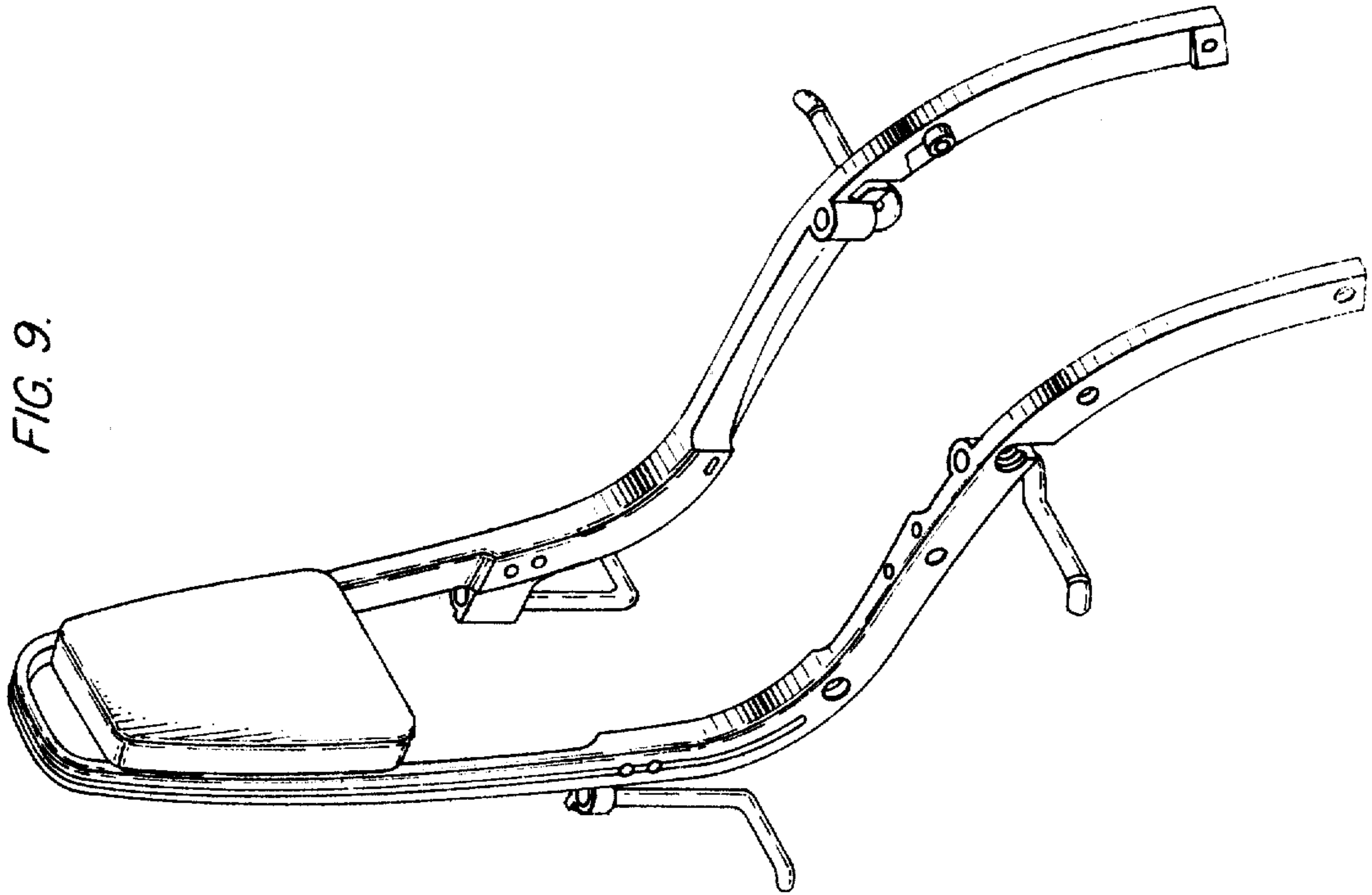

FIG. 8.

