

[54] LIFT TRUCK BODY

[75] Inventors: Warner K. Brown, Battle Creek, Mich.; Dennis M. Lanci, Renton, Wash.

[73] Assignee: Clark Equipment Company, Buchanan, Mich.

[\*\*] Term: 14 Years

[21] Appl. No.: 288,625

[22] Filed: Jul. 30, 1981

[51] Int. Cl. .... D12-05

[52] U.S. Cl. .... D34/37

[58] Field of Search ..... D34/34, 37; 187/9 R; 180/89.14, 89.17, 89.18; 296/190

[56] References Cited

U.S. PATENT DOCUMENTS

- D. 181,187 10/1957 Davies .
- D. 240,294 6/1976 DePriester et al. .

OTHER PUBLICATIONS

Modern Materials Handling, 3/80, p. 58, Catapillar Lift Truck.

Modern Materials Handling, 5/6/80, p. 145, Toyota Lift Truck.

Modern Materials Handling, 5/20/80, p. 13, Clark Lift Truck, bottom of page.

Modern Materials Handling, 7/79, p. 121, Magline Lift Truck, top of page.

Primary Examiner—James M. Gandy

Attorney, Agent, or Firm—J. C. Wiessler

[57] CLAIM

The ornamental design of a lift truck body, as shown and described.

DESCRIPTION

FIG. 1 is a right side perspective view of lift truck body, showing our new design;

FIG. 2 is a left side perspective view;

FIG. 3 is an enlarged rear perspective view;

FIG. 4 is an enlarged front perspective view; and

FIG. 5 is an elevated right rear quarter perspective view thereof.

Portions shown in broken lines are included for illustrative purposes only.

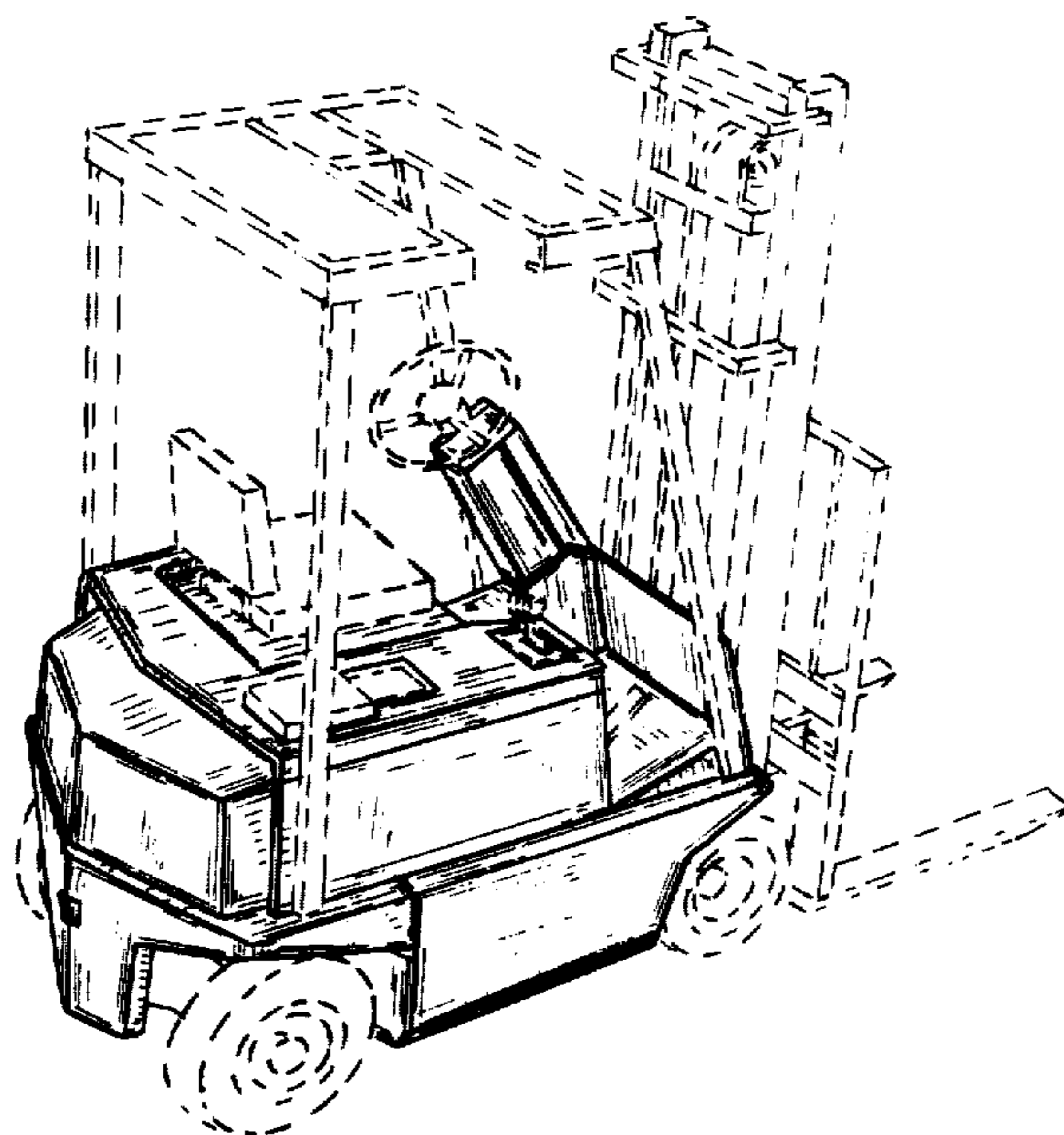

FIG. 1

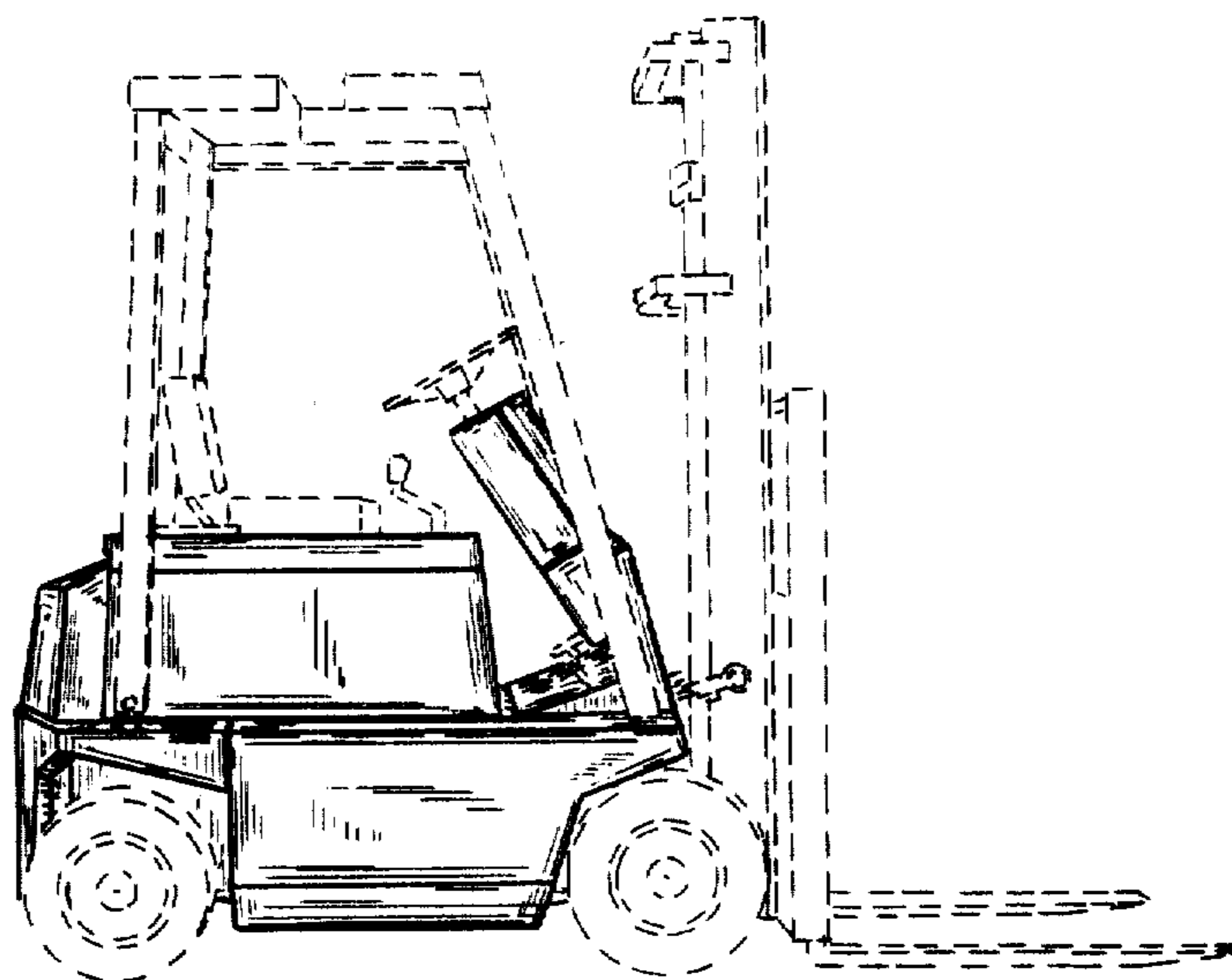

FIG. 2

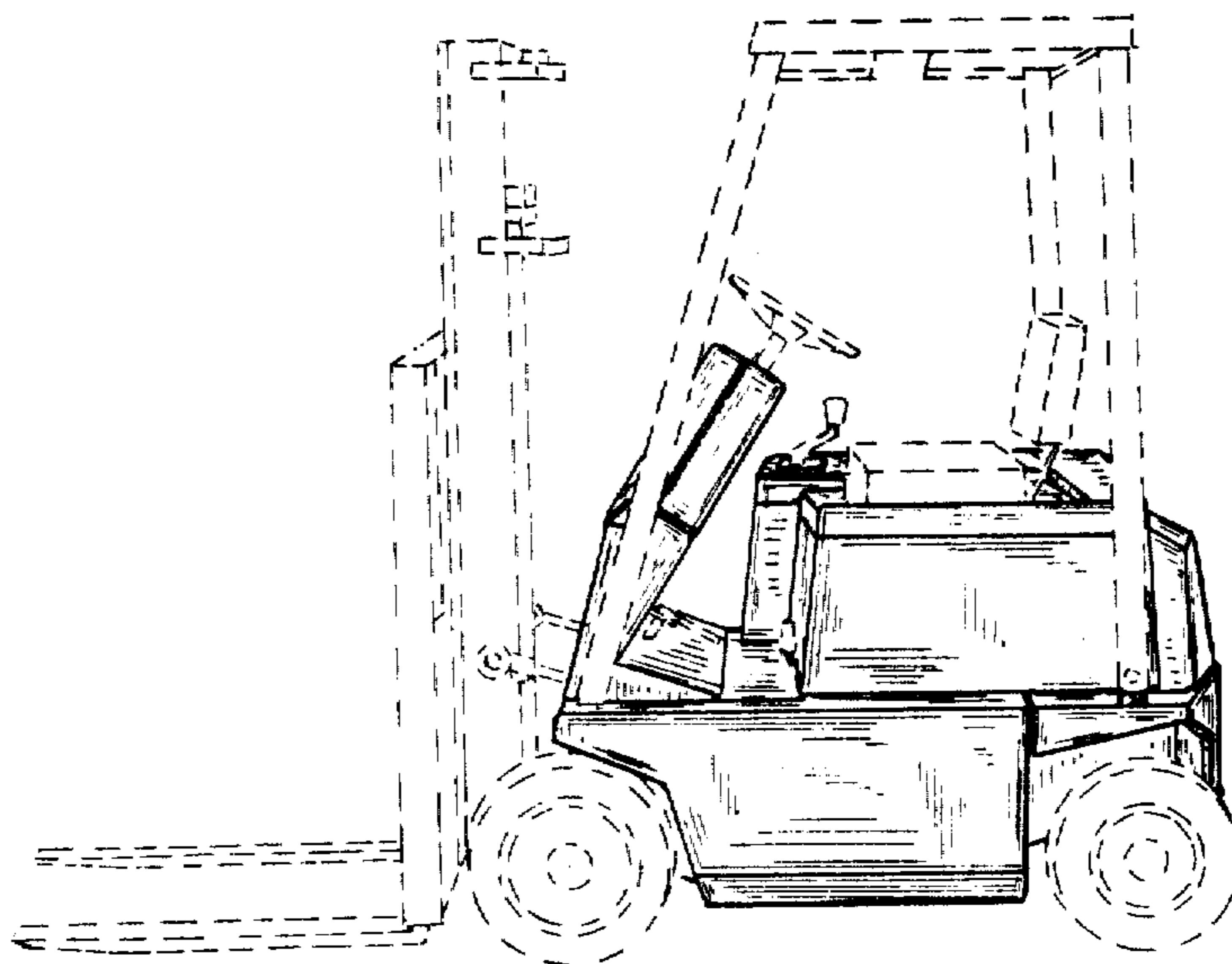

FIG. 3

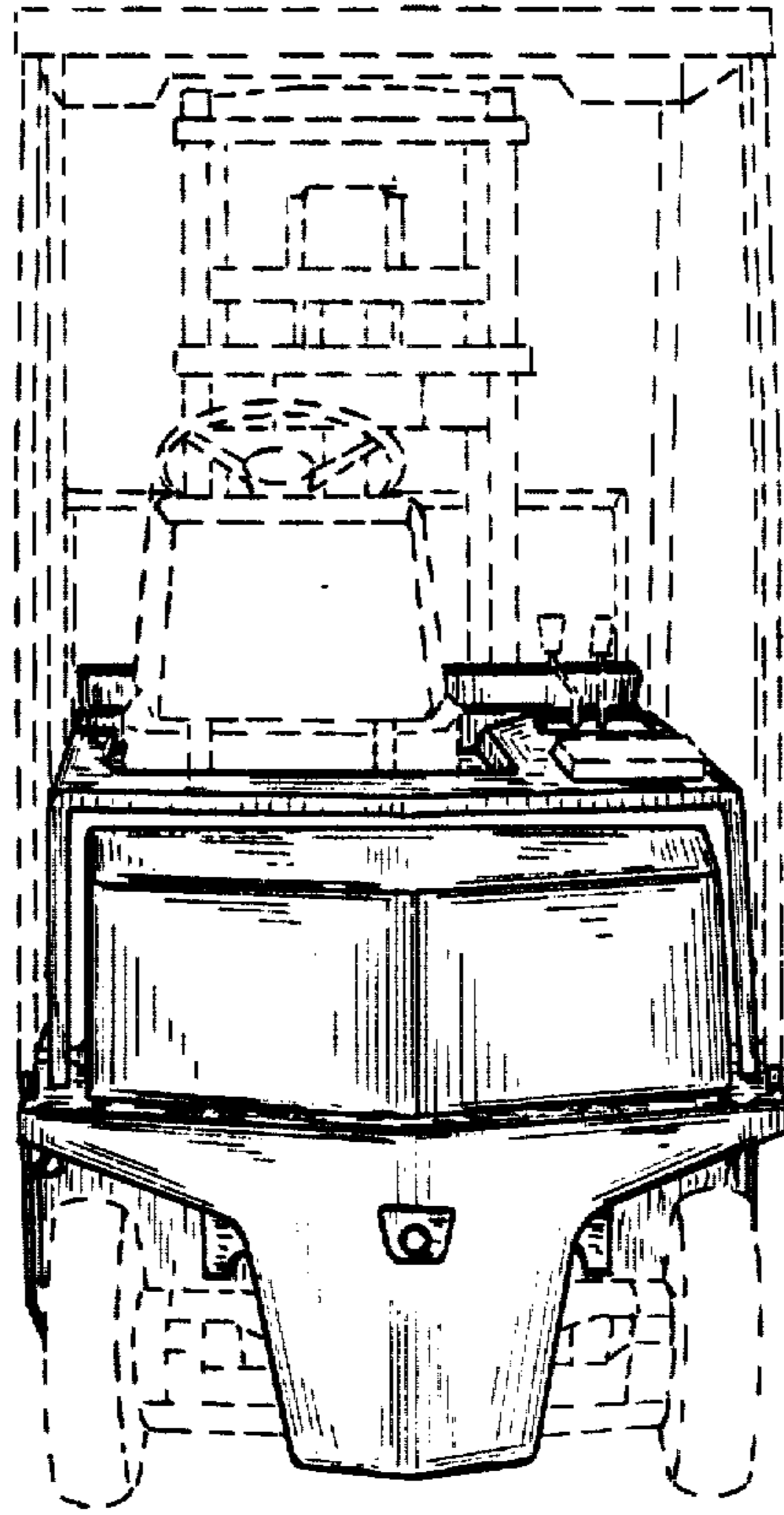

FIG. 4

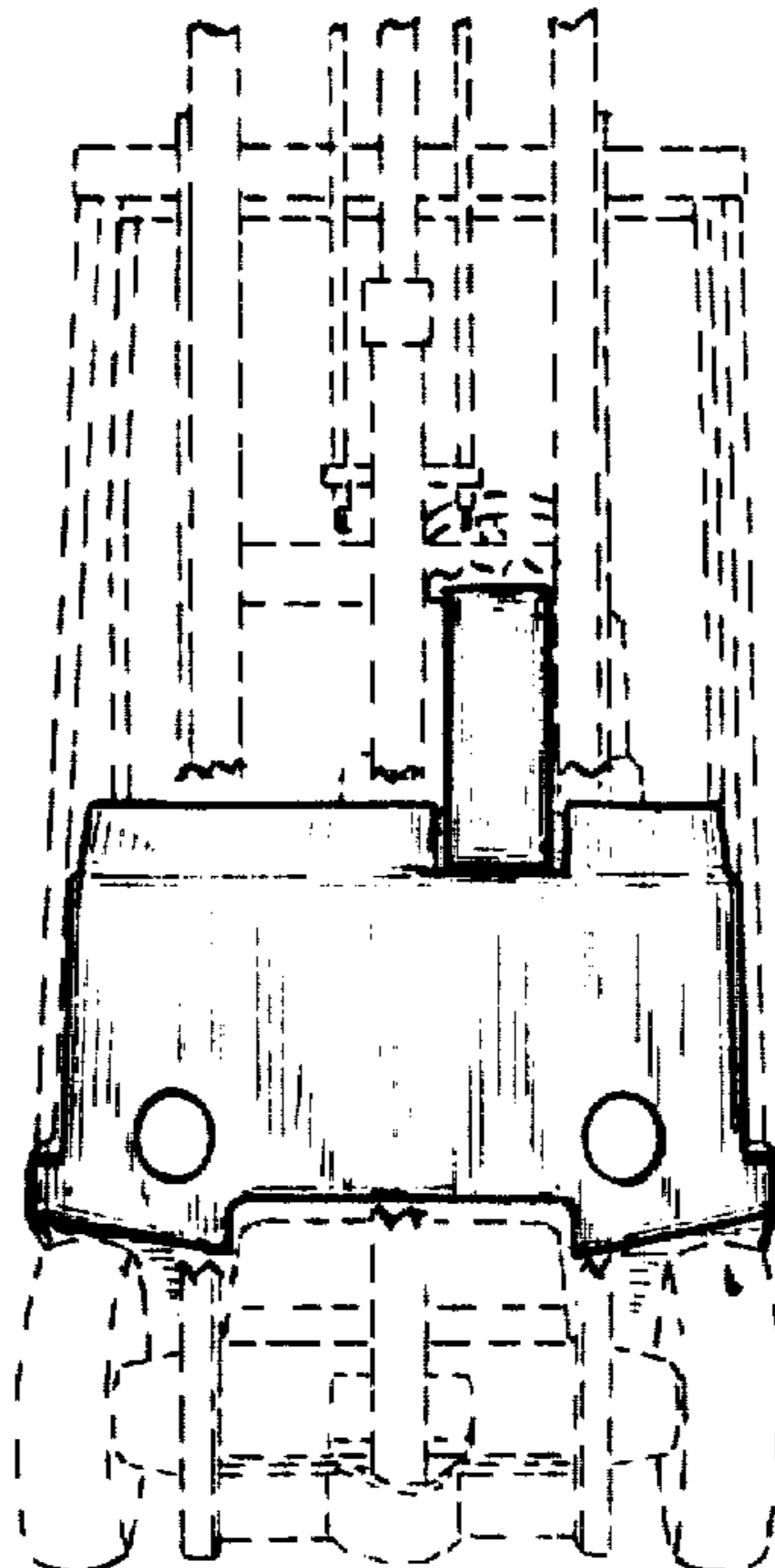

FIG. 5

