

[54] ELEVATED CREEPER FOR AUTOMOTIVE MECHANICS

2,843,391 7/1958 Pelletier ..... 280/32.6  
3,737,007 6/1973 Herrell ..... D34/30

[76] Inventor: Clarence W. Linn, 1501 Academy, Lodi, Calif. 95240

Primary Examiner—James M. Gandy  
Attorney, Agent, or Firm—Lothrop & West

[\*\*] Term: 14 Years

[57] CLAIM

[21] Appl. No.: 281,259

The ornamental design for an elevated creeper for automotive mechanics, as shown and described.

[22] Filed: Jul. 8, 1981

DESCRIPTION

[51] Int. Cl. .... D12-14

[52] U.S. Cl. .... D34/17

[58] Field of Search ..... D34/17, 23, 30; 280/32.6

FIG. 1 is a front left perspective view of an elevated creeper for automotive mechanics;  
FIG. 2 is an elevational view of one side thereof, the opposite side being a mirror image;  
FIG. 3 is a elevational view similar to FIG. 2 but showing the creeper board support pipes clamped in elevated position;

[56] References Cited

U.S. PATENT DOCUMENTS

- D. 230,971 3/1974 Shanklin ..... D34/23
- D. 247,035 1/1978 Brodmann ..... D34/17
- 1,104,398 7/1914 Zimmerman ..... 280/32.6

FIG. 4 is a front elevational view thereof;  
FIG. 5 is a rear elevational view thereof;  
FIG. 6 is a top plan view thereof; and,  
FIG. 7 is a bottom plan view thereof.

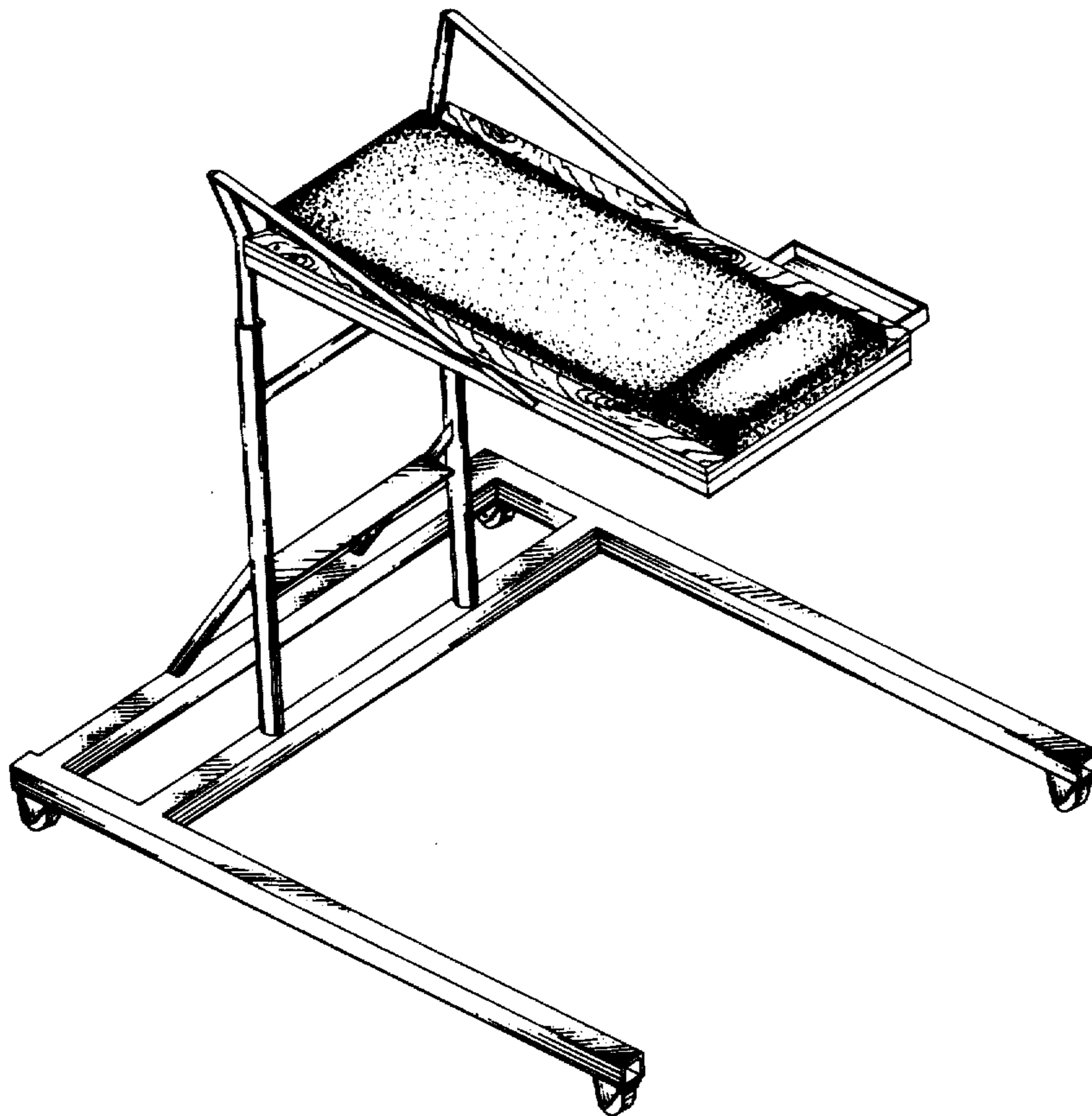

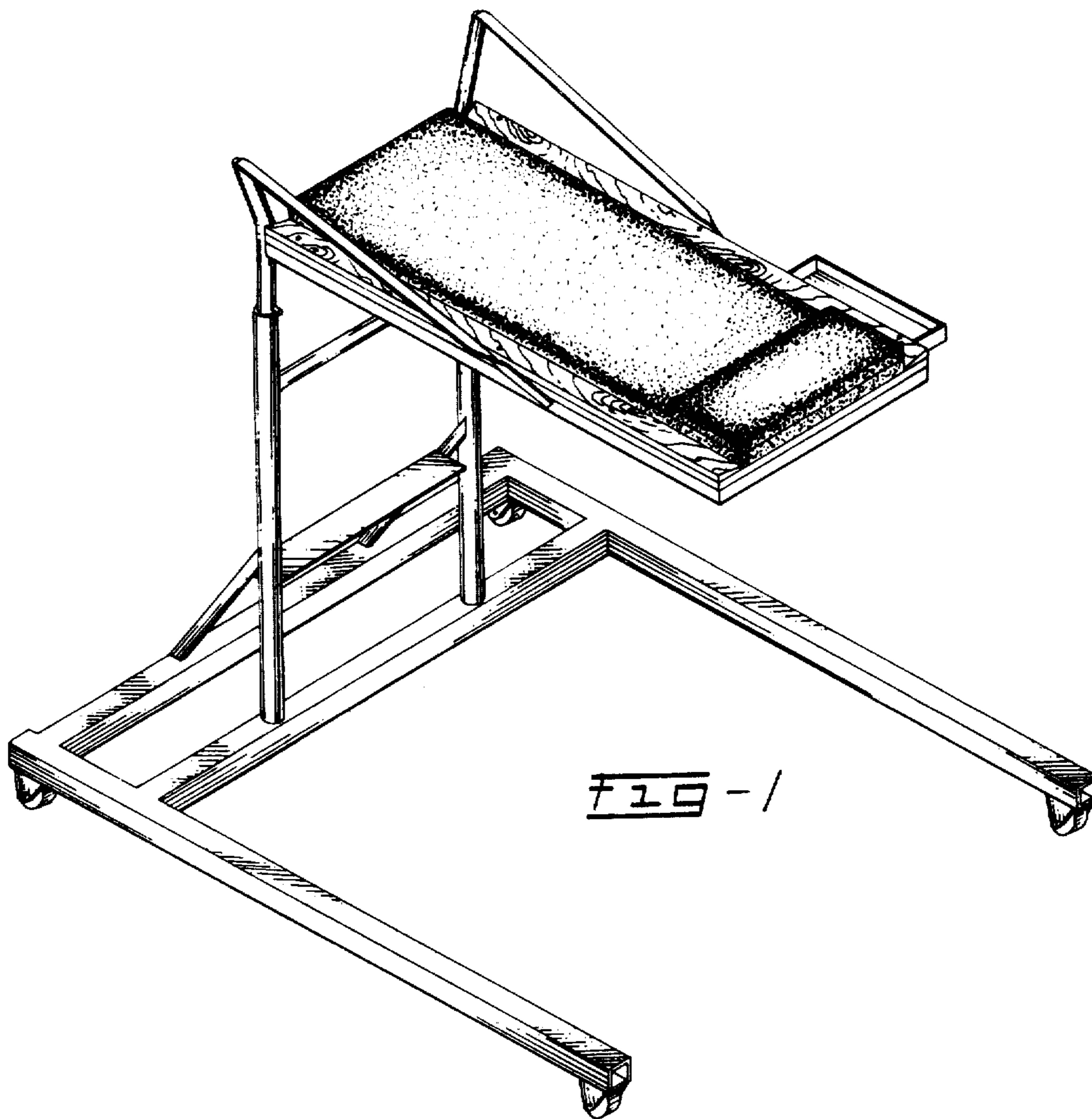

FIG-1

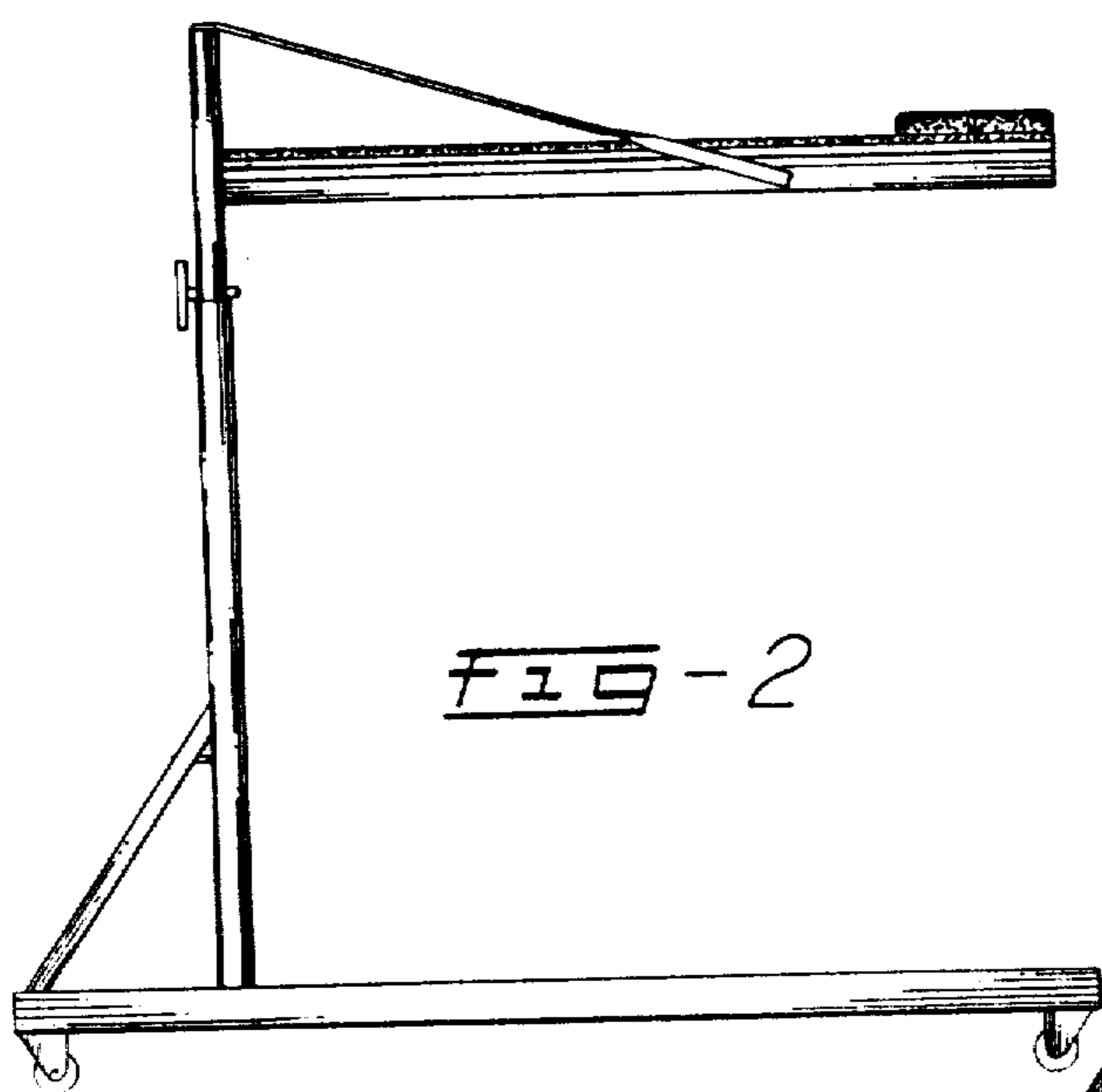

FIG-2

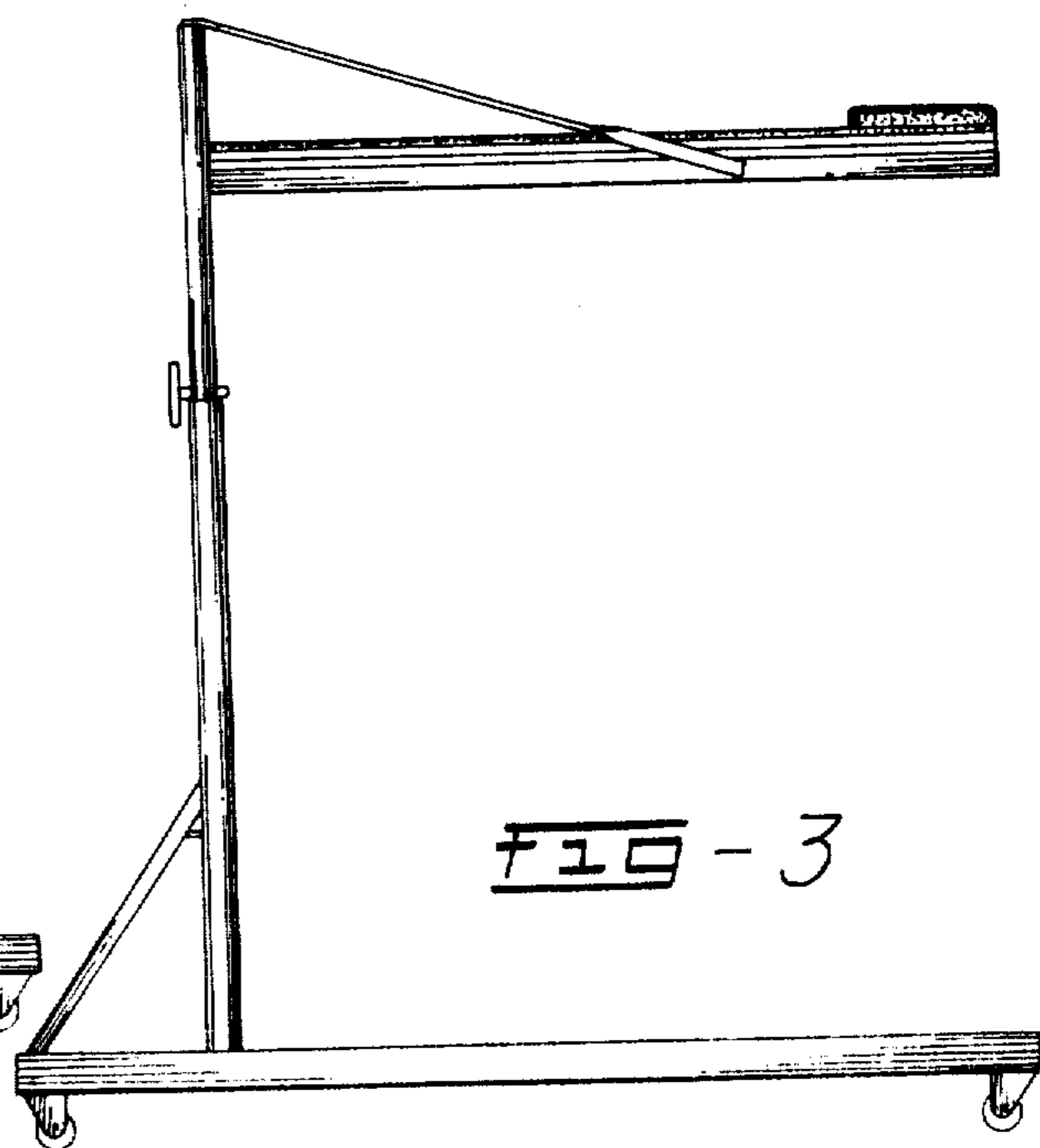

FIG-3

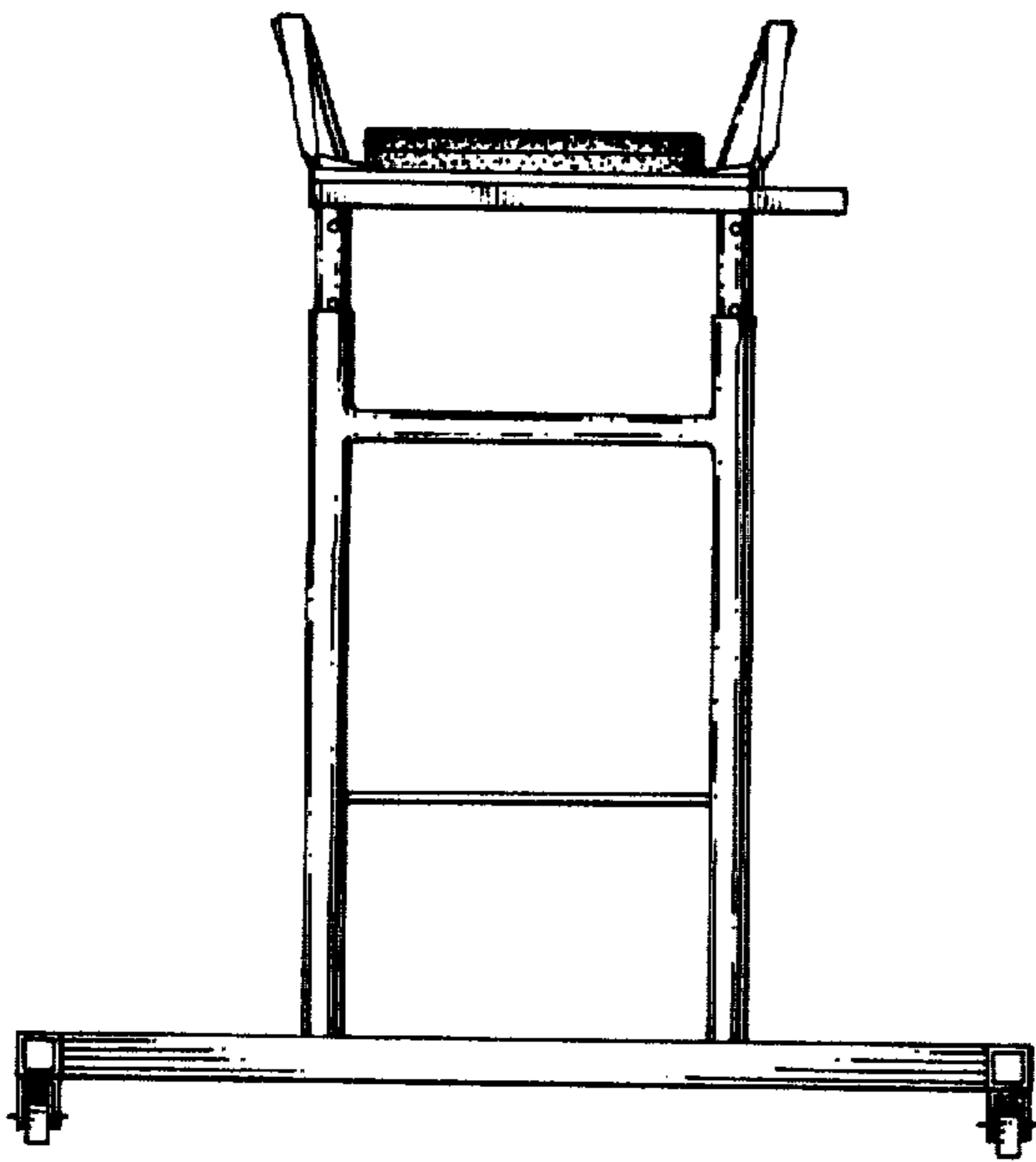

FIG-4

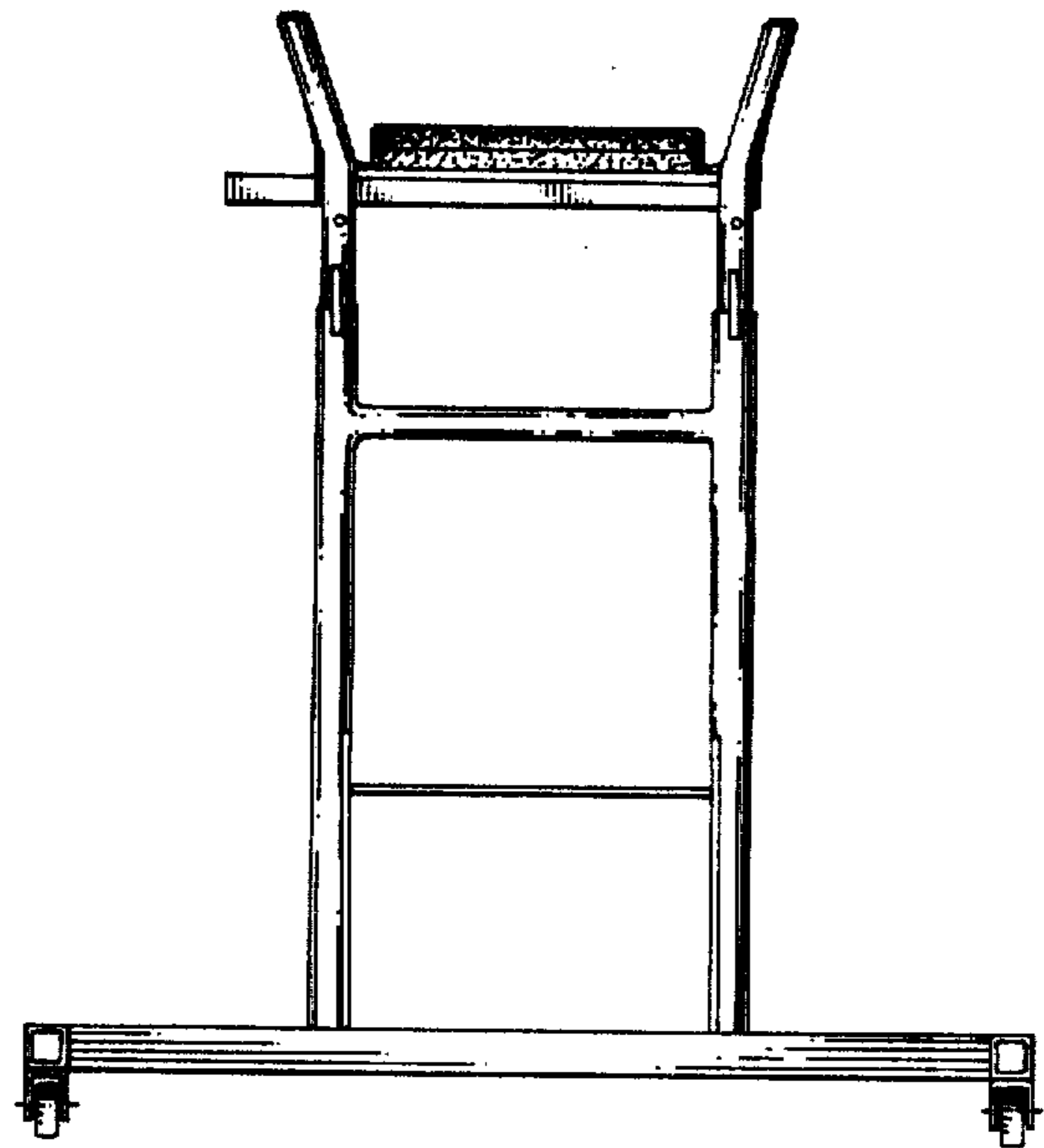

FIG-5

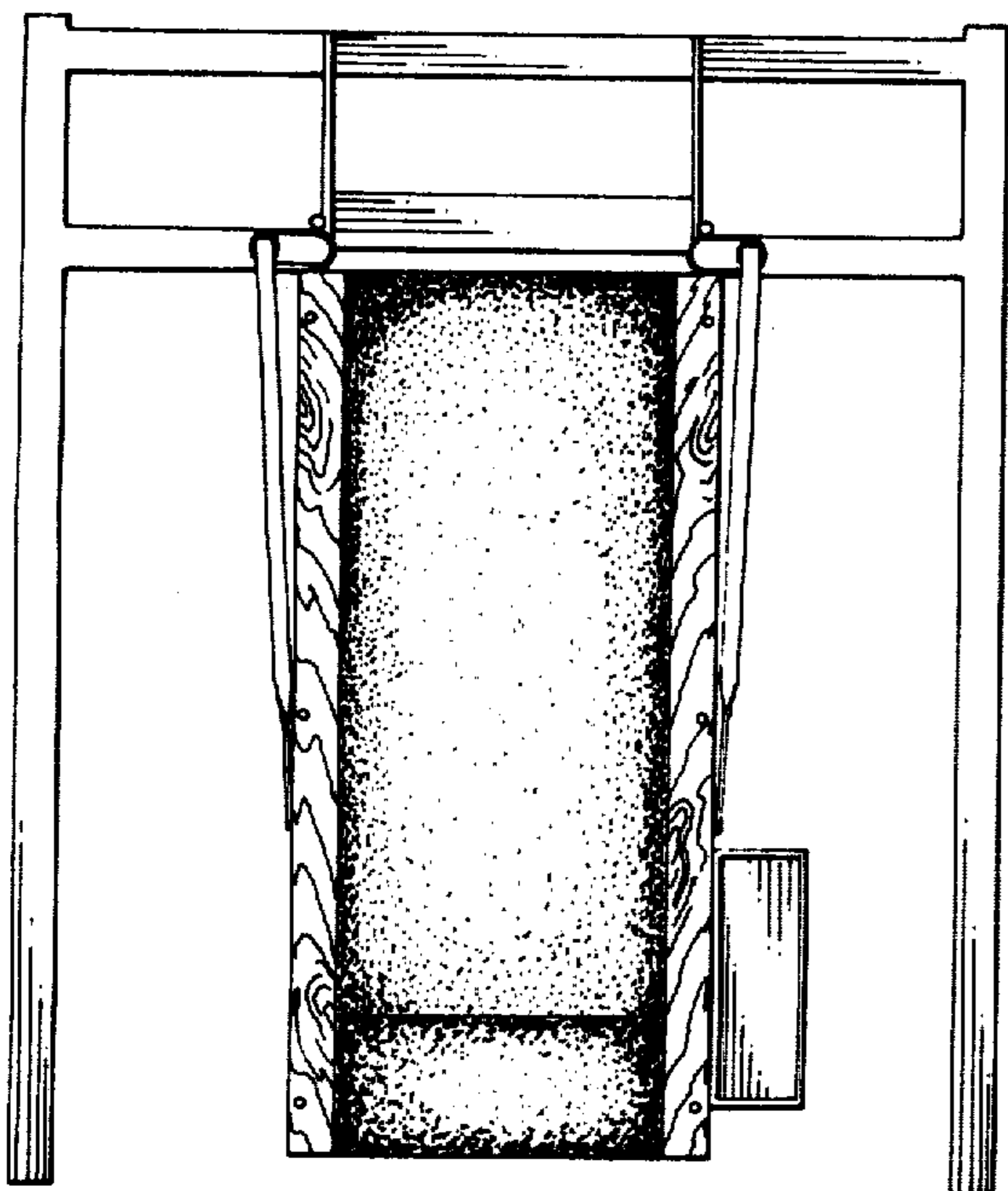

FIG-6

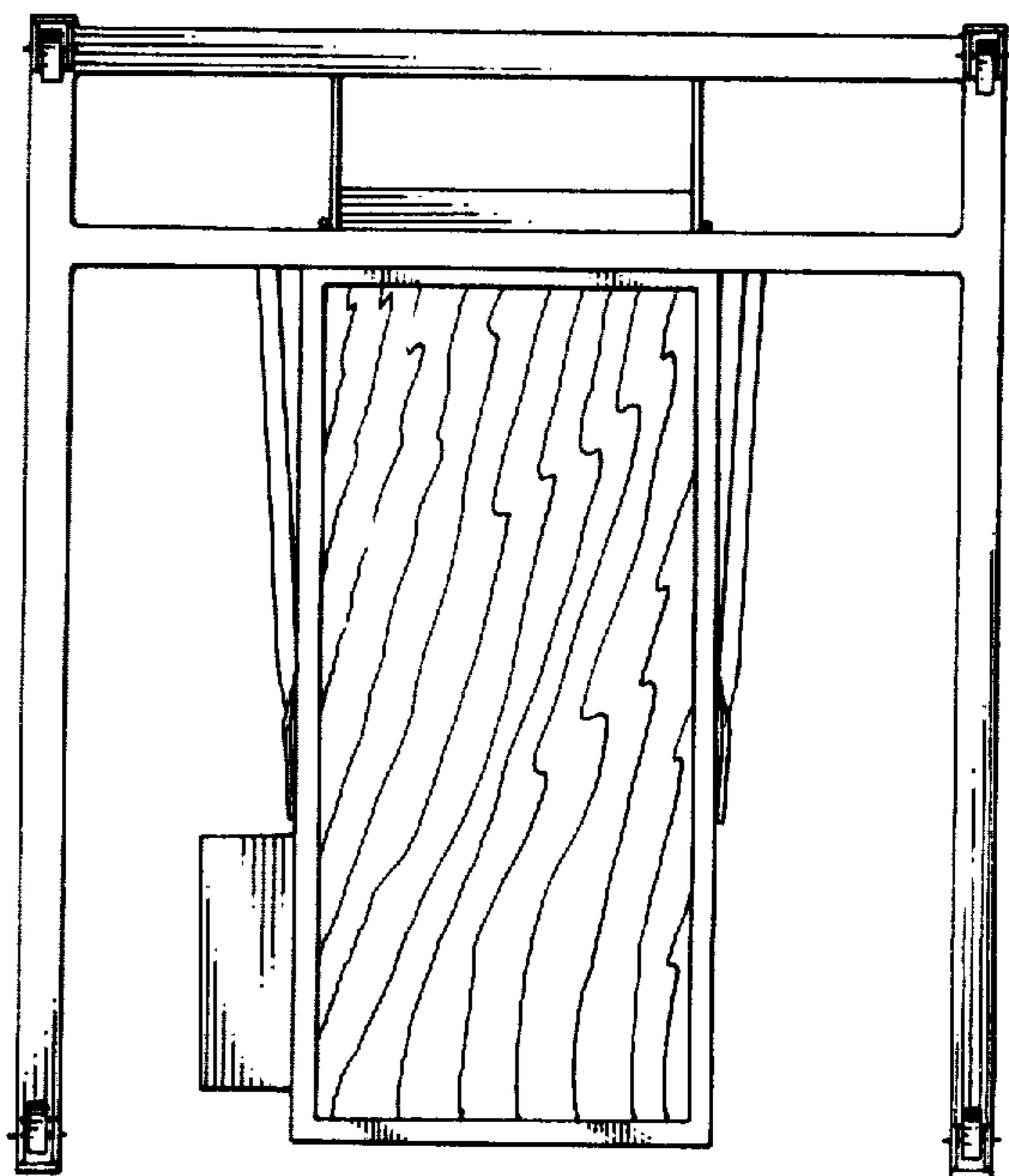

FIG-7