

[54] **LUGGAGE CARRIER**

[75] Inventors: **Mark Turkington; Philip Turkington,**  
both of Willimantic, Conn.

[73] Assignee: **Connecticut Cycle Accessories, Inc.,**  
Willimantic, Conn.

[\*\*] Term: **14 Years**

[21] Appl. No.: **285,150**

[22] Filed: **Jul. 20, 1981**

[51] Int. Cl. .... **D12-11**

[52] U.S. Cl. .... **D12/158**

[58] Field of Search ..... **D12/158; 224/32 A, 39**

**References Cited**

**U.S. PATENT DOCUMENTS**

- D. 222,984 2/1972 Heltzen et al. .... D12/158
- D. 244,928 7/1977 Oakes ..... D12/158

**OTHER PUBLICATIONS**

Cycle World, 9/71, p. 87, Luggage Rack, center left side of page.

J. C. Whitney Catalog No. 336, ©1975, p. 143, Rear Luggage Carrier for Honda 750 K1 to 750 K9, second box down from top left side of page.

*Primary Examiner*—James M. Gandy

[57] **CLAIM**

The ornamental design for a luggage carrier, as shown and described.

**DESCRIPTION**

FIG. 1 is a top perspective view of a luggage carrier showing our new design;

FIG. 2 is a side elevational view thereof;

FIG. 3 is a side elevational view of a luggage carrier showing a second embodiment of our new design; and

FIG. 4 is a top perspective view of FIG. 3.

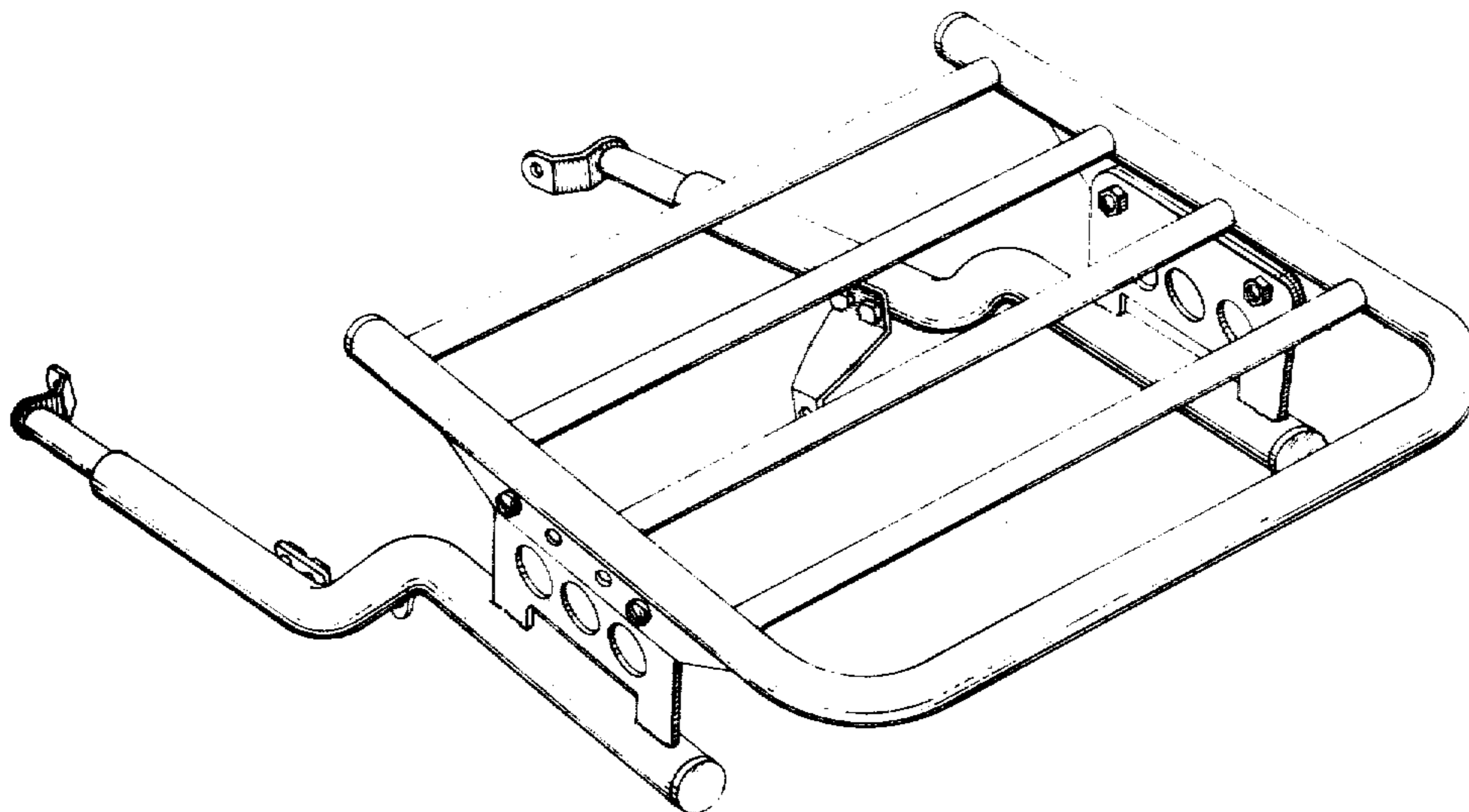

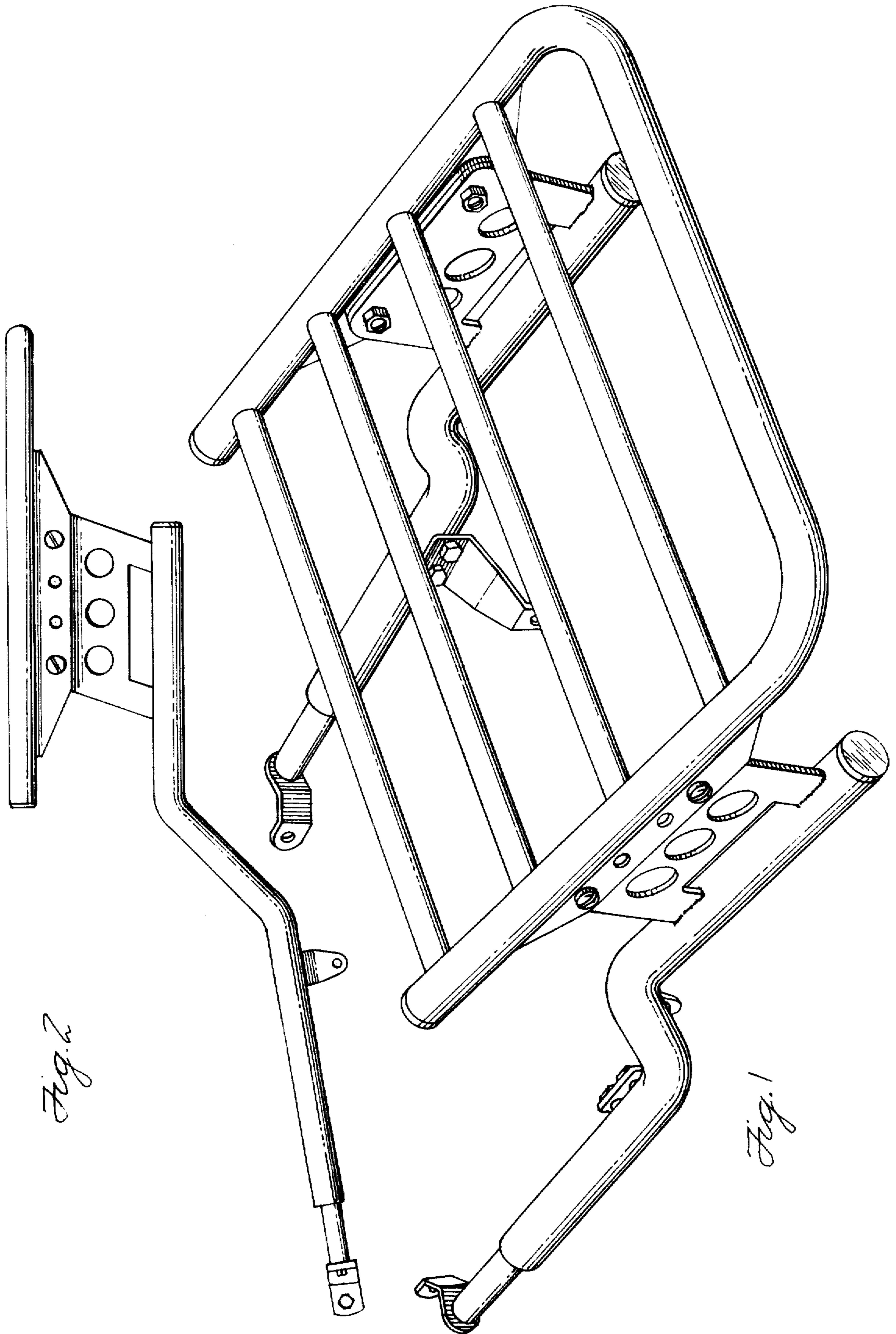

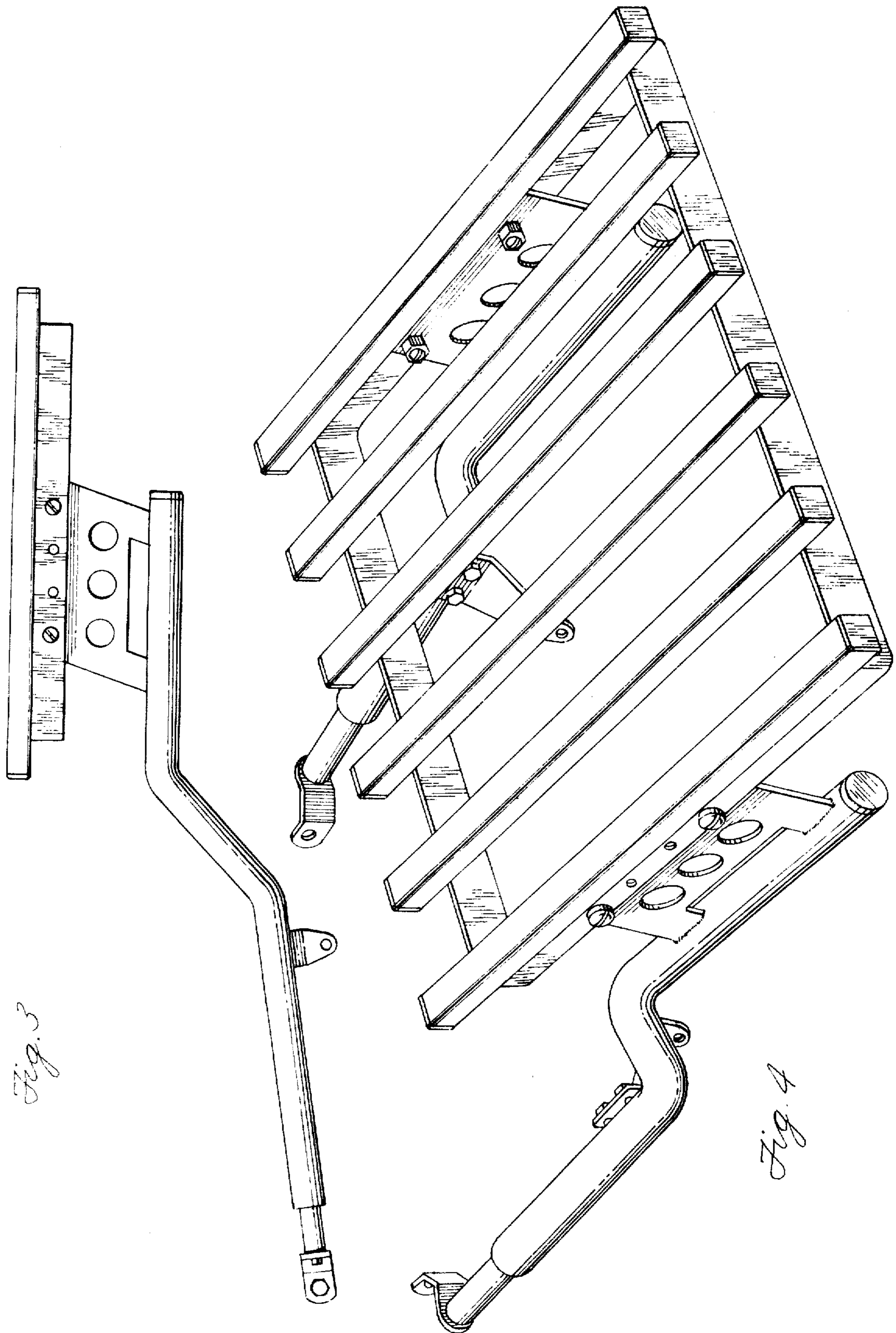

*Fig. 3*

*Fig. 4*