

[54] HEAVY DUTY MACHINE CARRIAGE
 [75] Inventors: William J. Coughlin, Lancaster;
 David E. Johnson, Pataskala; Kenneth
 E. McCall, Lancaster, all of Ohio
 [73] Assignee: Arcair Company, Lancaster, Ohio
 [**] Term: 14 Years
 [21] Appl. No.: 235,339
 [22] Filed: Feb. 17, 1981
 [51] Int. Cl. D12-03
 [52] U.S. Cl. D12/36
 [58] Field of Search D15/144; D12/36, 37;
 266/67

2,253,540 8/1941 Stoneberg 266/67
 2,466,143 4/1949 Young 266/67

Primary Examiner—James M. Gandy
 Attorney, Agent, or Firm—James C. Simmons; E.
 Eugene Innis

[57] CLAIM

The ornamental design for a heavy duty machine carriage, as shown.

DESCRIPTION

FIG. 1 is a top plan view of a heavy duty machine carriage showing our new design.
 FIG. 2 is a bottom plan view thereof on a reduced scale.
 FIG. 3 is an elevational view thereof looking in the direction of line 3—3 in FIG. 1;
 FIG. 4 is an elevational view thereof looking in the direction of line 4—4 in FIG. 1; and
 FIG. 5 is an elevational view thereof looking in the direction of line 5—5 in FIG. 1.

[56] References Cited
 U.S. PATENT DOCUMENTS
 1,320,687 11/1919 Harris 266/67

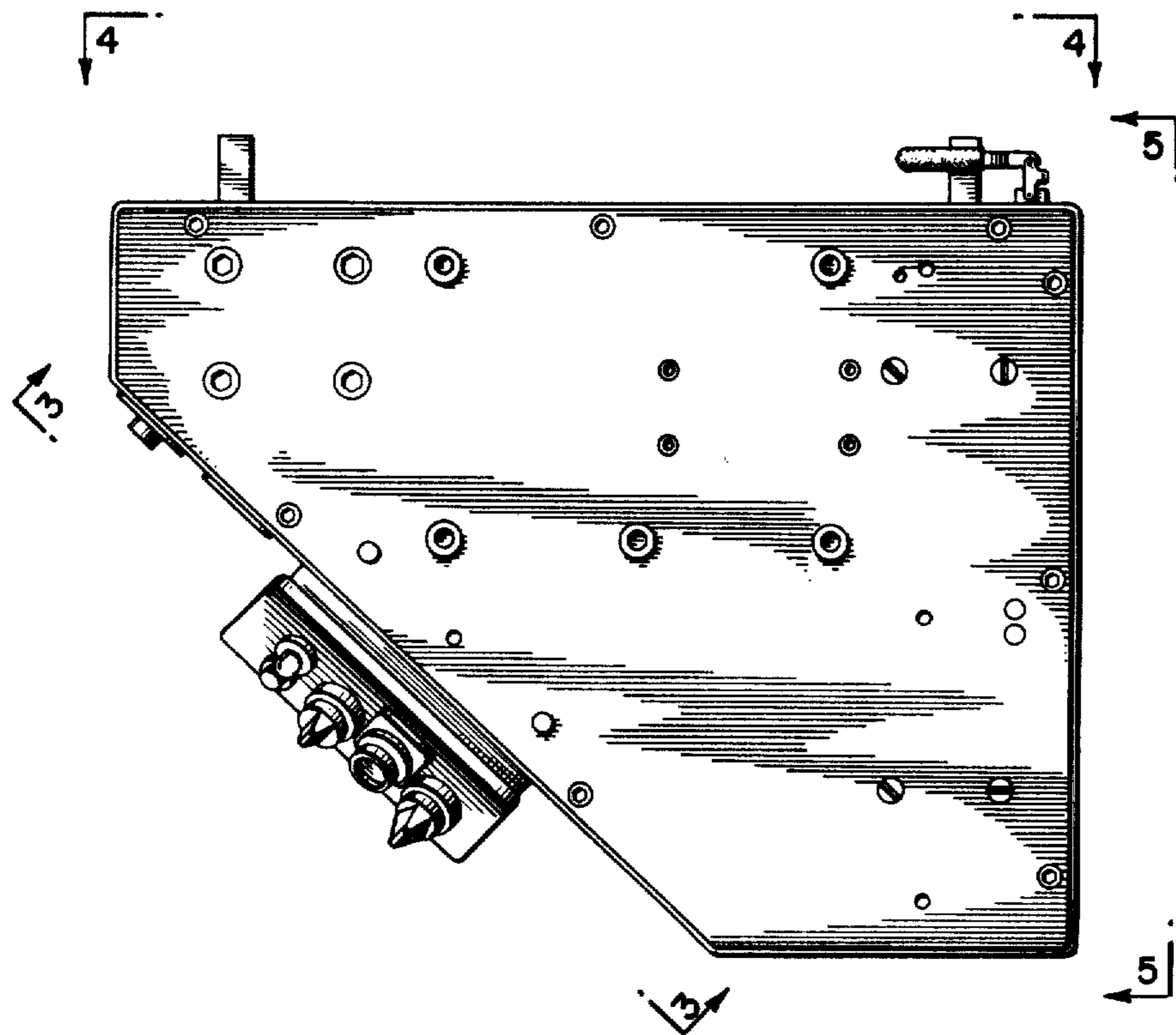

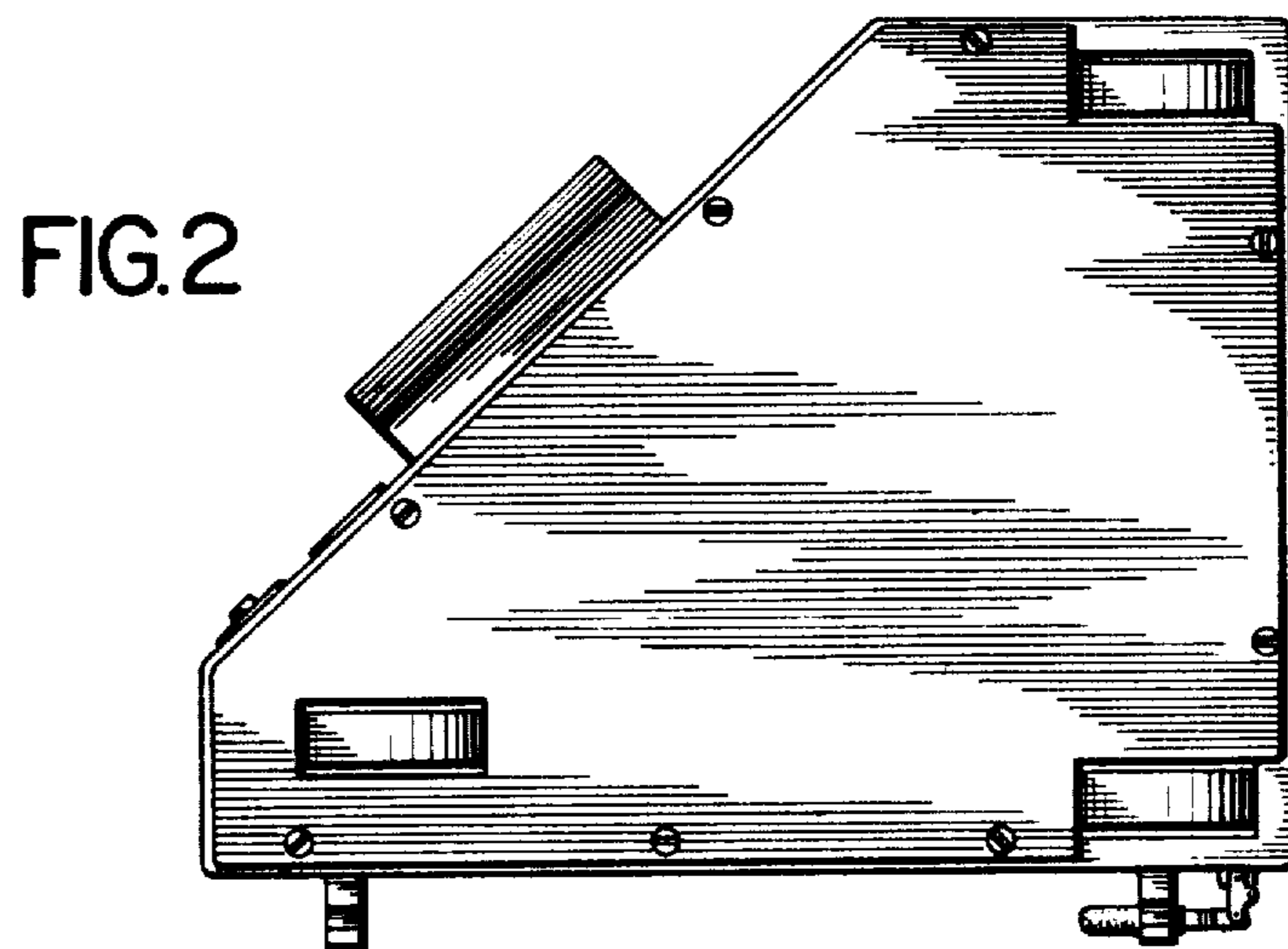
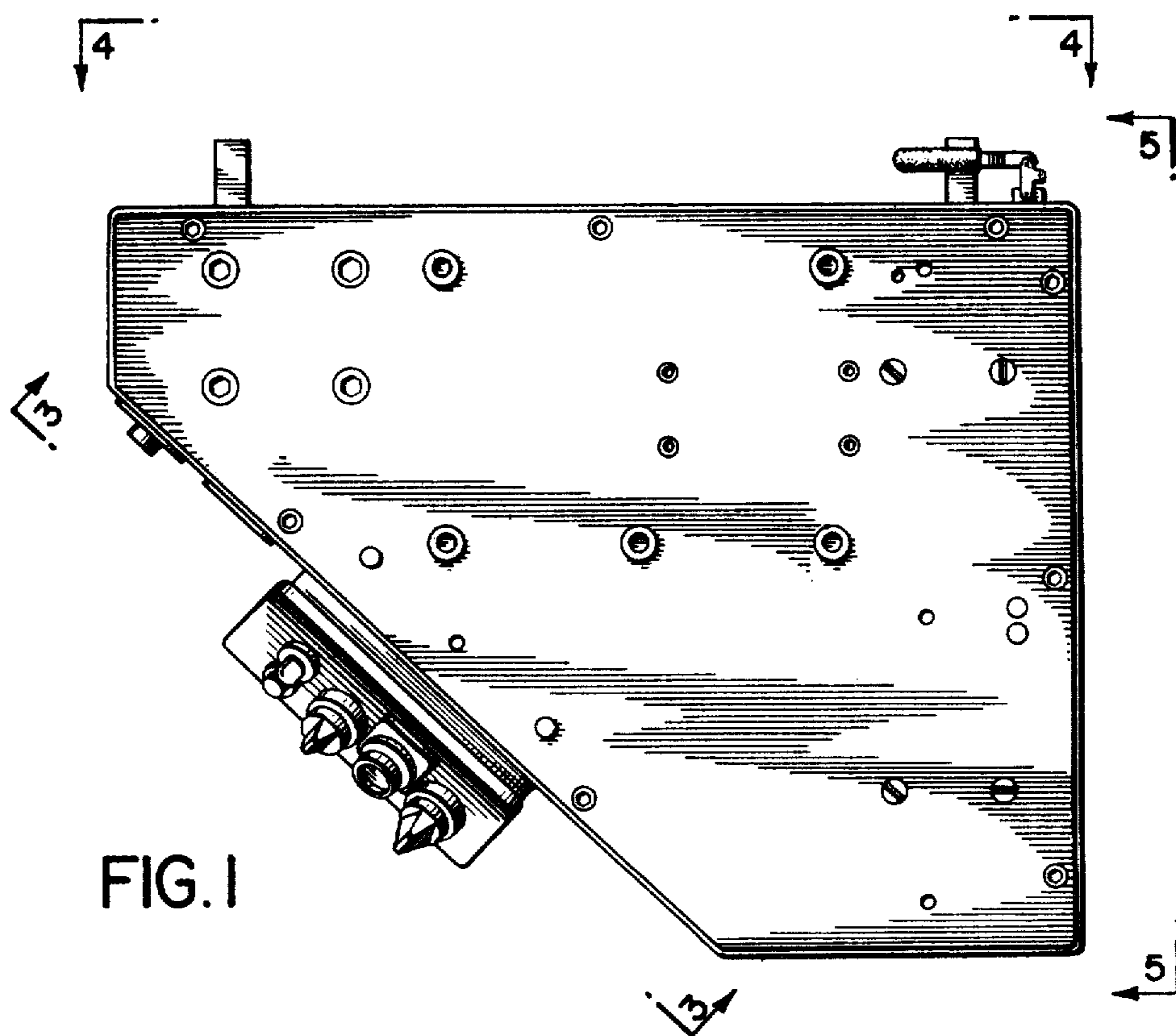

FIG. 3

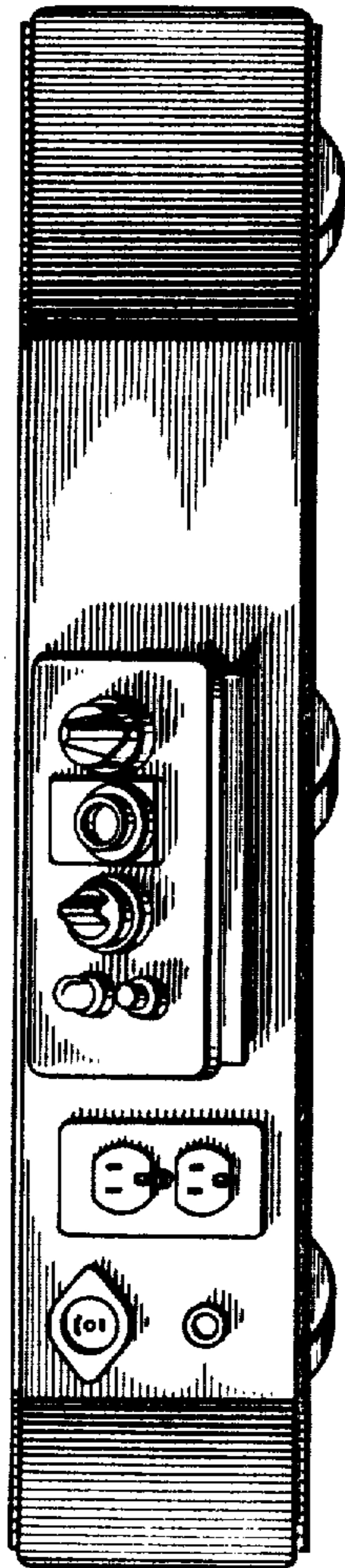

FIG. 4

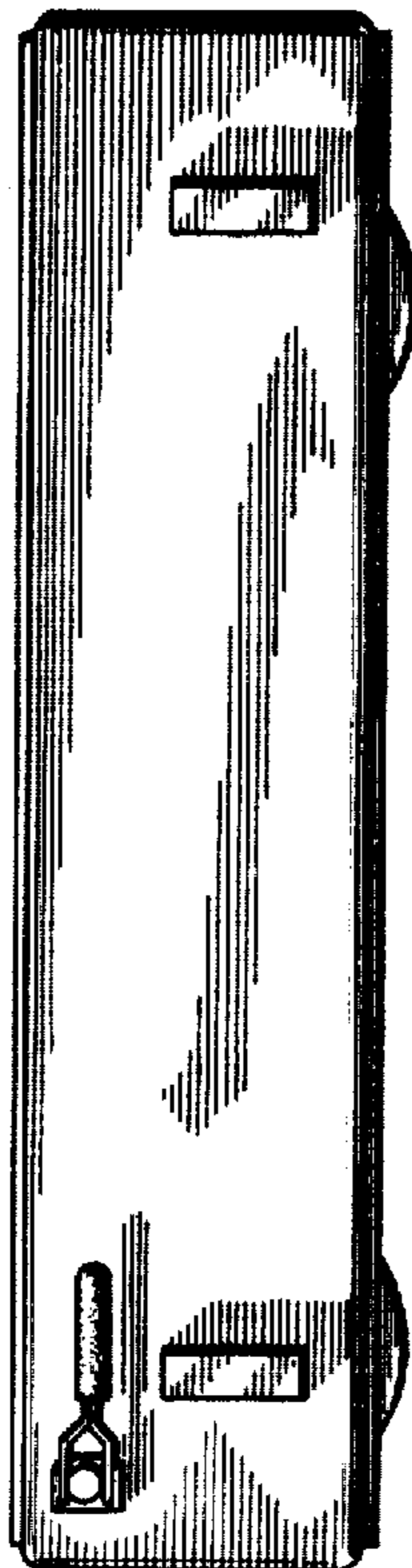

FIG. 5

