

[54] **CAMERA**

[75] Inventor: **Koichi Soda**, Toyko, Japan

[73] Assignee: **Ricoh Company, Ltd.**, Japan

[**] Term: **14 Years**

[21] Appl. No.: **299,611**

[22] Filed: **Sep. 4, 1981**

[30] **Foreign Application Priority Data**

Mar. 4, 1981 [JP] Japan 56-8861

[51] Int. Cl. **D16-01**

[52] U.S. Cl. **D16/1**

[58] Field of Search D16/1, 6, 8, 9, 10,
D16/2; 354/288, 202

[56] **References Cited**

U.S. PATENT DOCUMENTS

- D. 178,272 7/1956 Birbaum D16/1
- D. 219,407 12/1970 Fukuda D16/8
- D. 247,041 1/1978 Fukuda D16/6

OTHER PUBLICATIONS

Fujica Flash S Flyer #OP-1-137s-3/79—Camera on front cover.

Minolta Contact Sheet #19-Fall/Winter 1979—Minolta AF Camera at upper left of group at bottom-p. 1.

Flash Fujica Flyer #OP1-148e-9/79—camera on cover.

Primary Examiner—Nelson C. Holtje

Attorney, Agent, or Firm—Guy W. Shoup

[57] **CLAIM**

The ornamental design for a camera, as shown and described.

DESCRIPTION

FIG. 1 is a front, top and left side perspective view of a camera showing my new design;

FIG. 2 is a front elevational view thereof;

FIG. 3 is a top plan view thereof;

FIG. 4 is a right side elevational view thereof;

FIG. 5 is a left side elevational view thereof;

FIG. 6 is a rear elevational view thereof; and

FIG. 7 is a bottom plan view thereof.

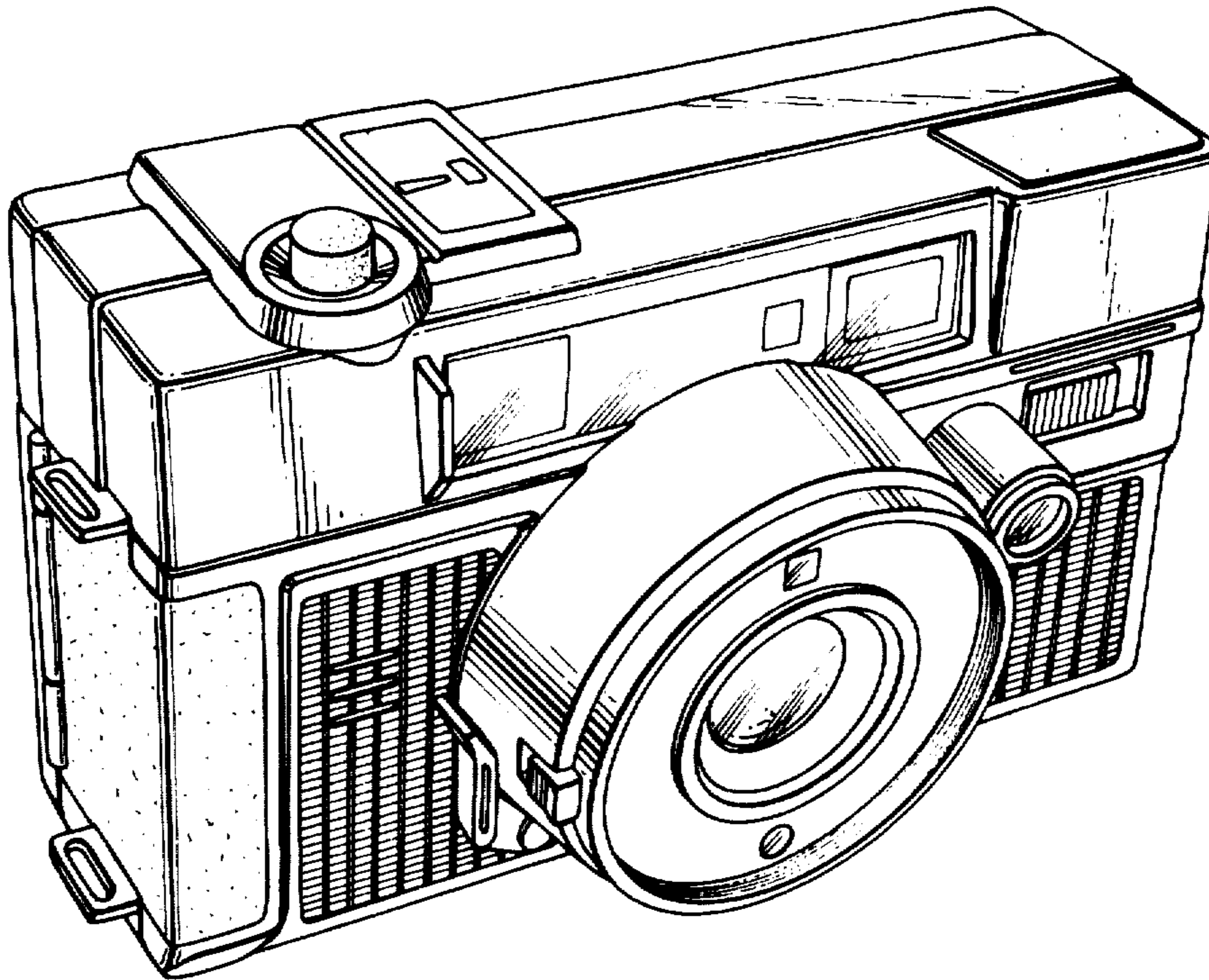

FIG. 1

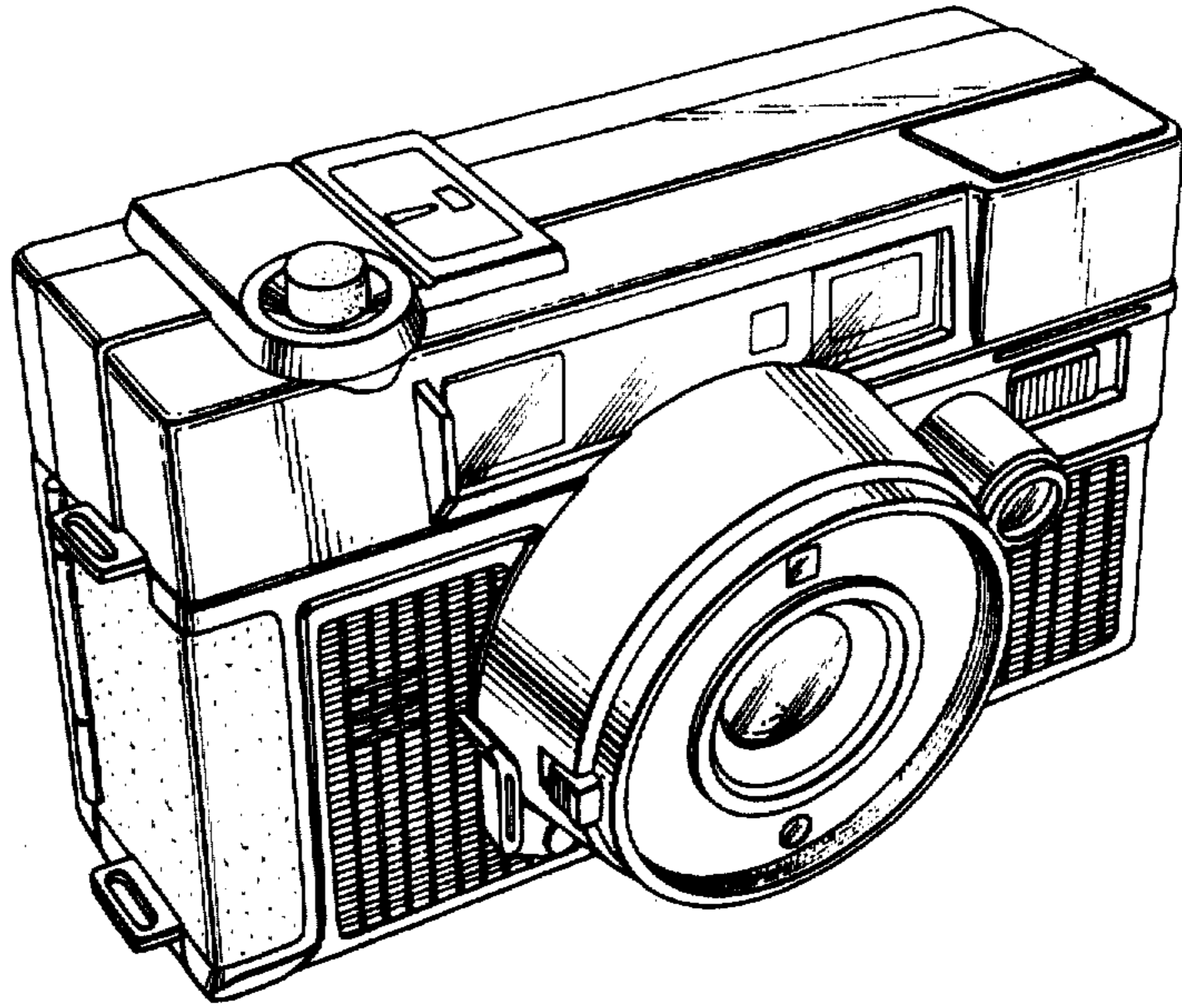

FIG. 2

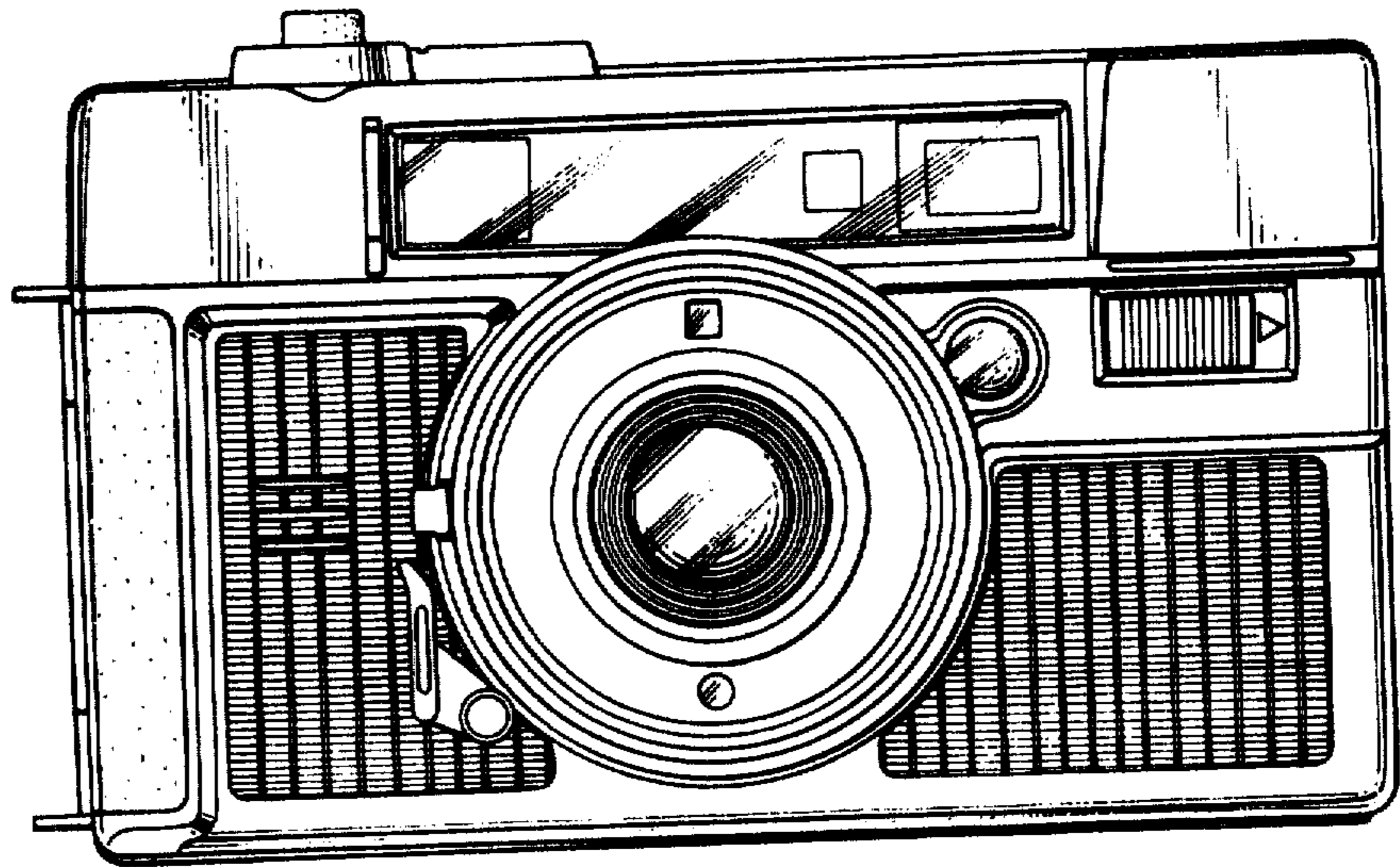

FIG. 3

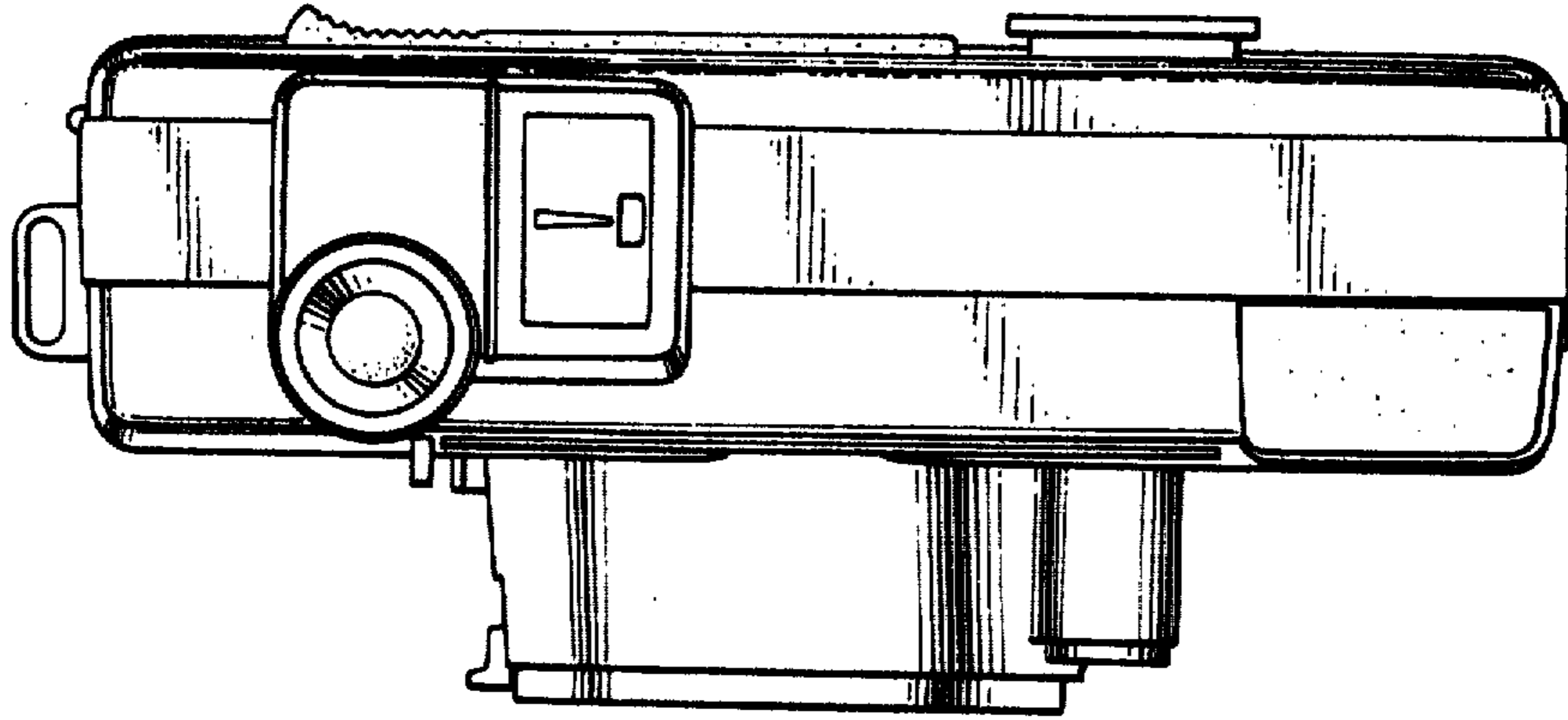

FIG. 4

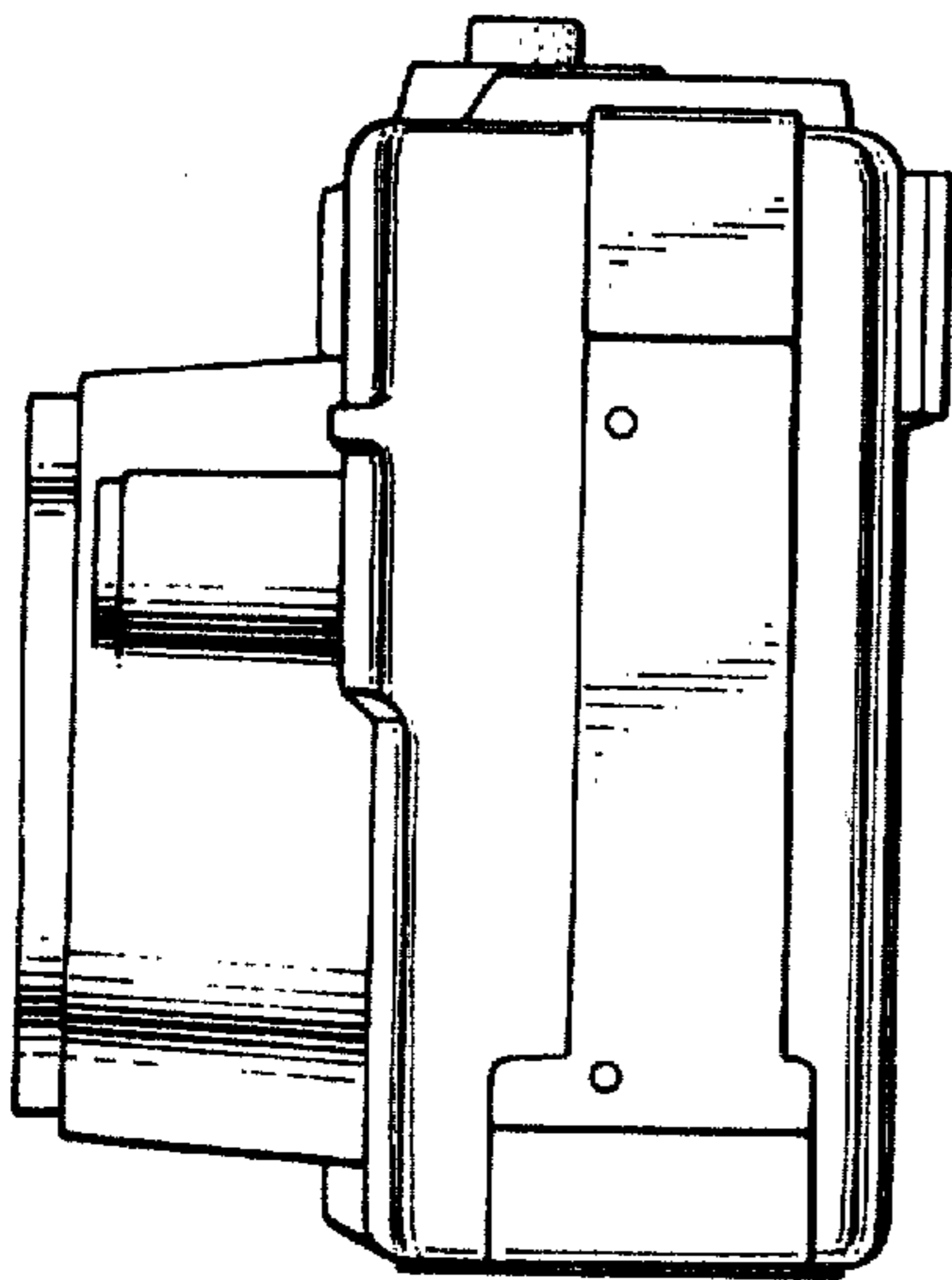

FIG. 5

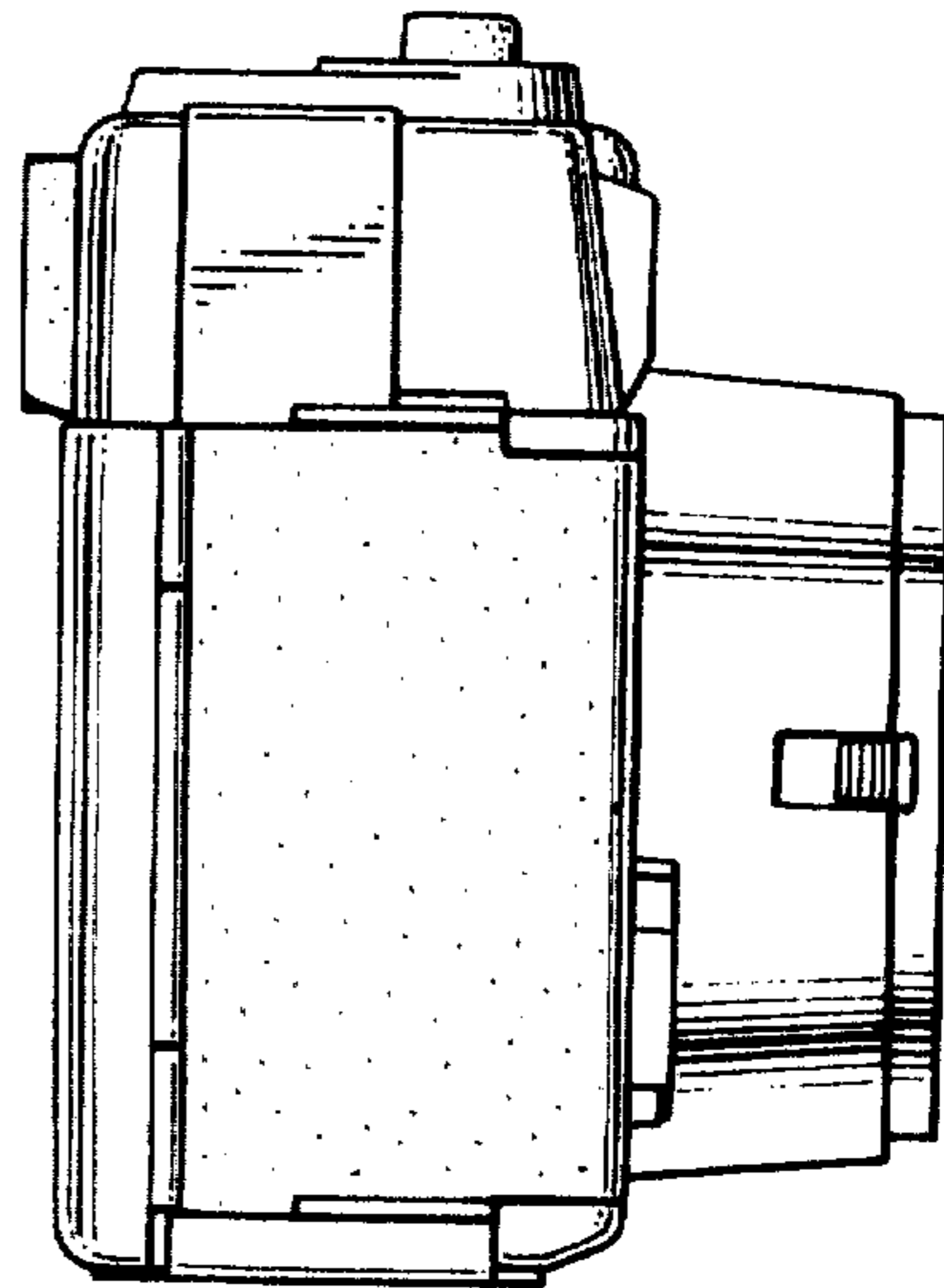

FIG. 6

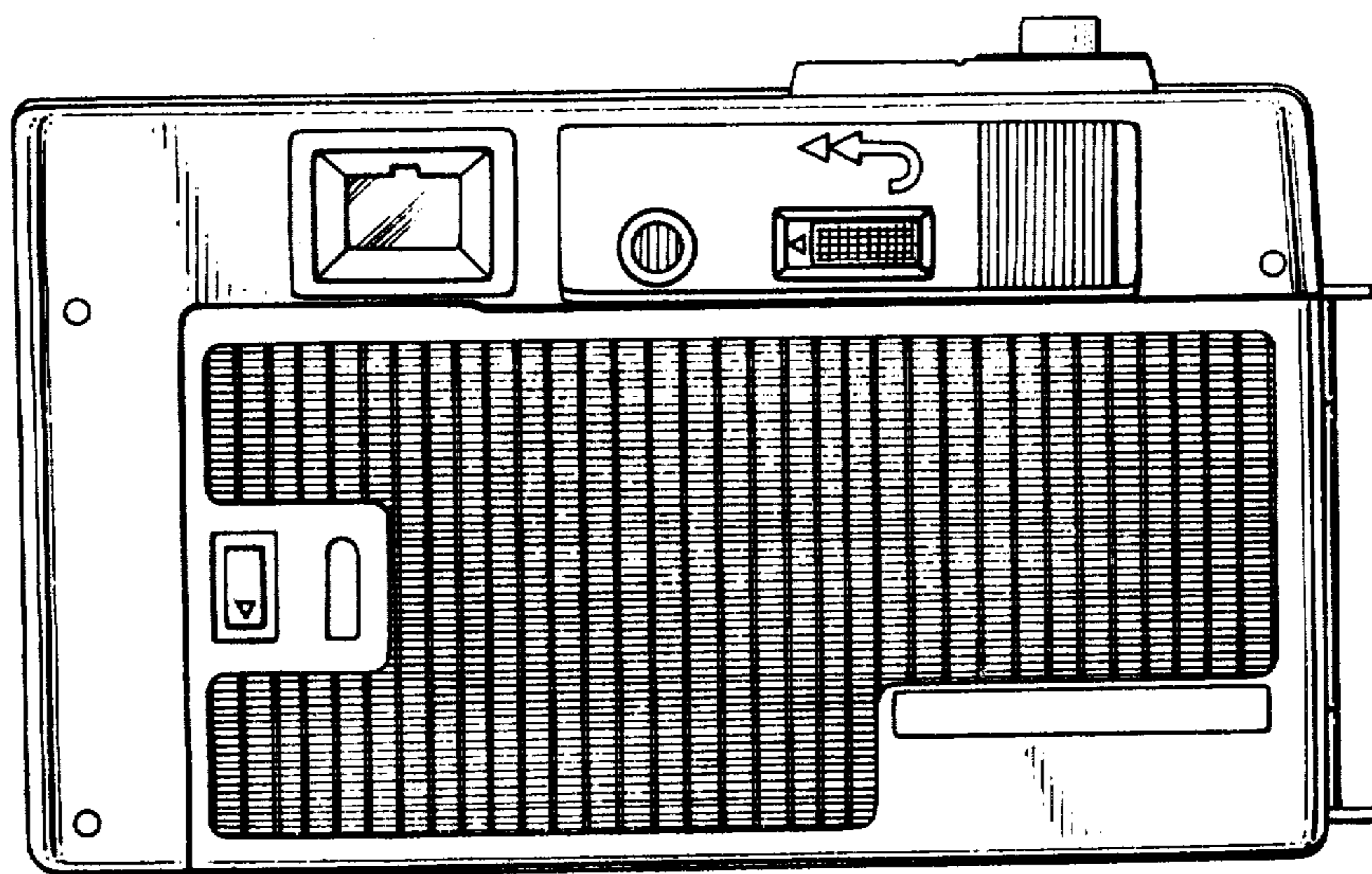

FIG. 7

