

[54] COMBINED PICKUP TRUCK CARGO BOX,
BED AND TAILGATE

[75] Inventor: James D. Stephenson, Sylmar, Calif.

[73] Assignee: Coach Products Corporation,
Gardena, Calif.

[**] Term: 14 Years

[21] Appl. No.: 291,234

[22] Filed: Aug. 10, 1981

[51] Int. Cl. D12-16

[52] U.S. Cl. D12/98

[58] Field of Search D12/98; 296/10, 50

[56] References Cited

U.S. PATENT DOCUMENTS

D. 256,901 9/1980 Carr, Jr. et al. D12/98

Primary Examiner—James M. Gandy
Attorney, Agent, or Firm—Edward A. Sokolski

[57] CLAIM

The ornamental design for a combined pickup truck cargo box, bed and tailgate, as shown and described.

DESCRIPTION

FIG. 1 is a perspective view of my new combined pickup truck cargo box, bed and tailgate; FIG. 2 is a rear elevational view thereof; and FIG. 3 is a side elevational view thereof.

The side opposite to that shown in FIG. 3 is the mirror image thereof.

The front of the claimed design is understood to be flat and unornamented.

The broken lines in the drawing are for illustrative purposes only.

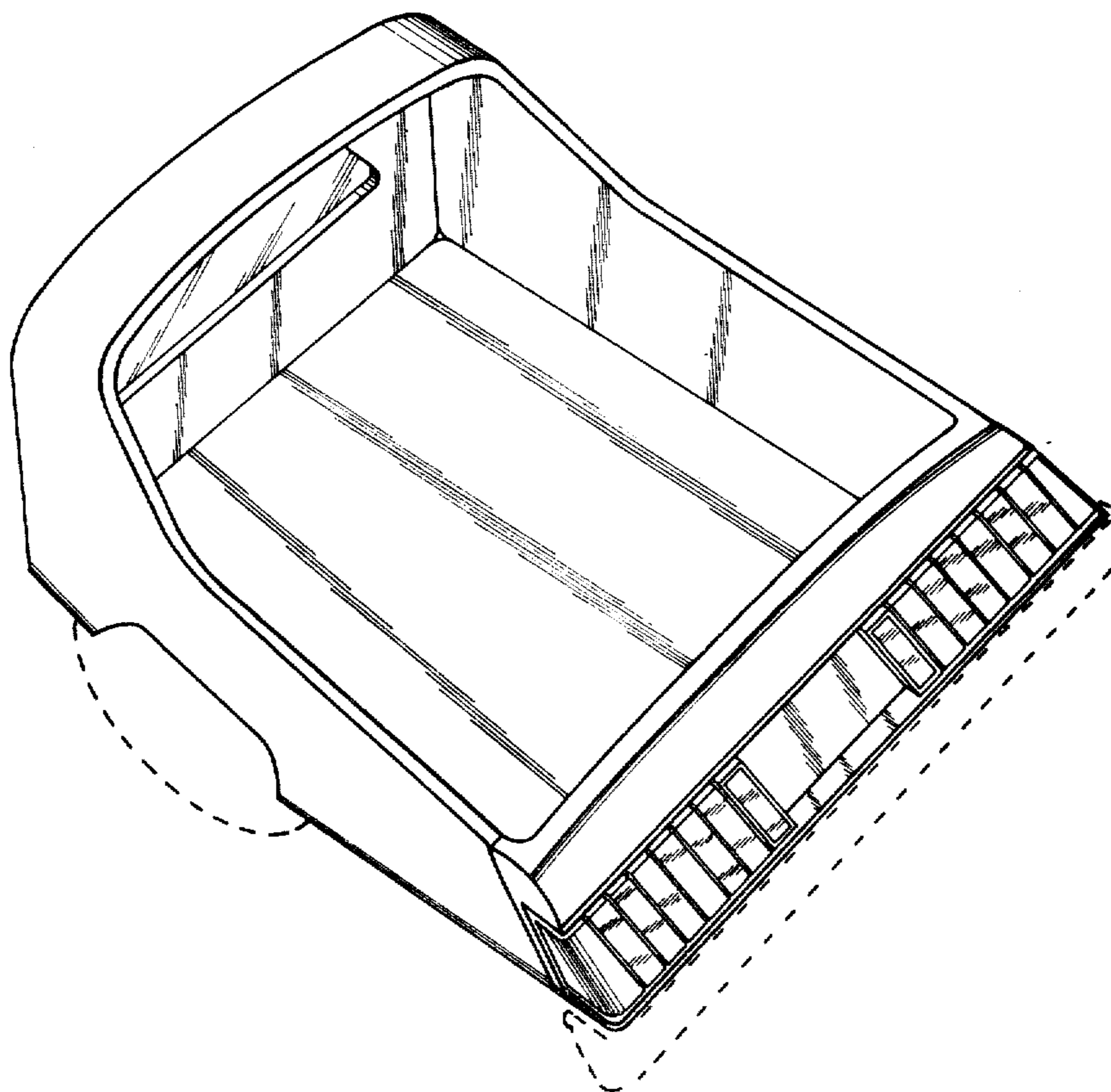

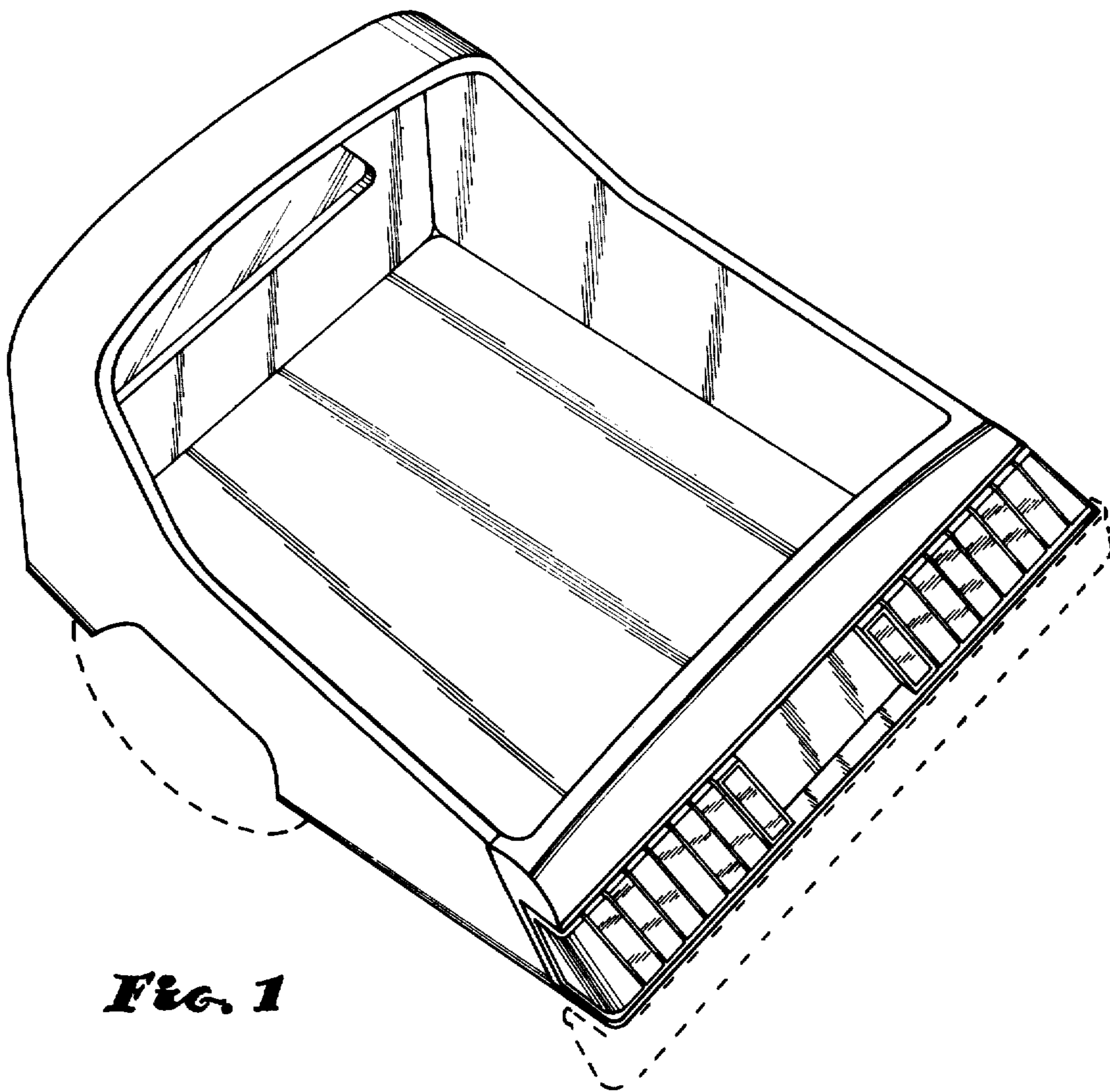

Fig. 1

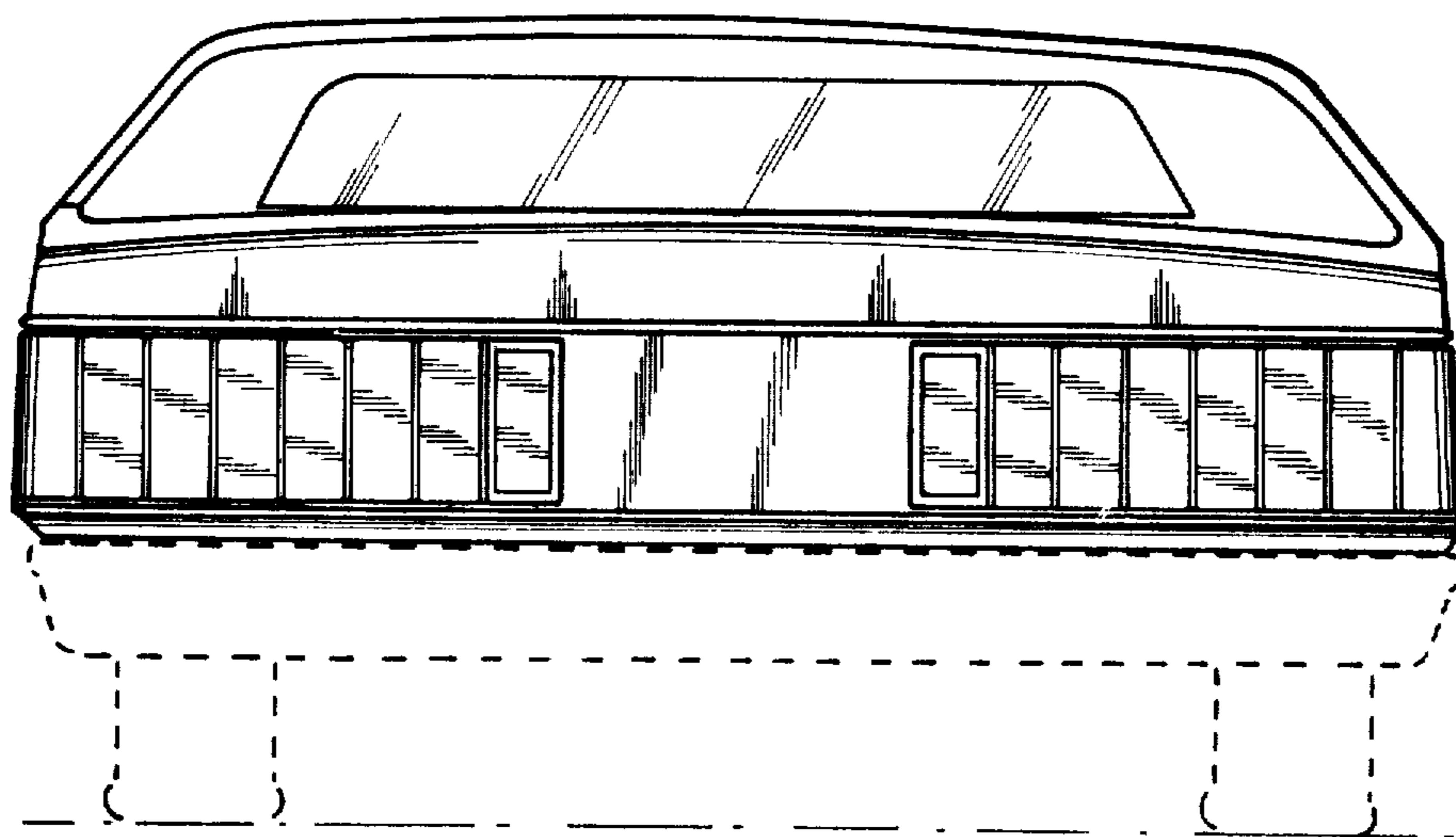

Fig. 2

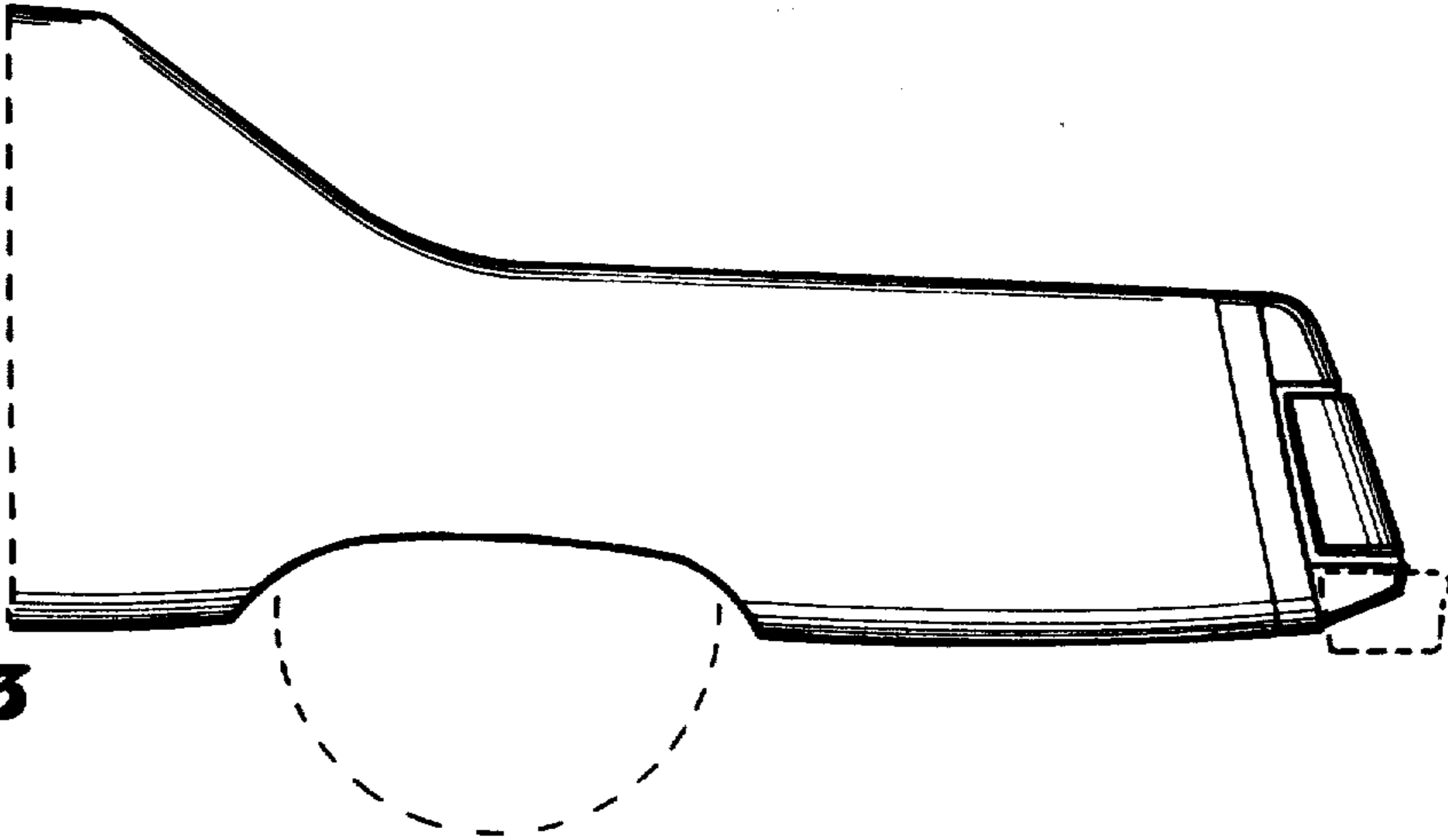

Fig. 3