

[54] OVERSHOE

[76] Inventor: Rae H. Archibald, 1 Nellie St., Clayfield, Queensland, 4011, Australia

[\*\*] Term: 14 Years

[21] Appl. No.: 256,318

[22] Filed: Apr. 22, 1981

[30] Foreign Application Priority Data

Nov. 5, 1980 [AU] Australia ..... 82530

[51] Int. Cl. .... D2-04

[52] U.S. Cl. .... D2/264; D2/271; D2/292

[58] Field of Search ..... D2/264, 271, 290, 292, D2/314, 317, 322, 324; 36/7.1 R, 7.5, 7.6, 11.5

[56] References Cited

U.S. PATENT DOCUMENTS

- D. 217,371 4/1970 Clark ..... D21/72
- D. 231,379 4/1974 Fields ..... D2/292 X
- D. 247,527 3/1978 Foldes ..... D2/303 X

- 843,199 2/1907 Doyle ..... 36/7.5
- 2,283,595 5/1942 Banister ..... D21/72 X
- 3,352,033 11/1967 Colley ..... 36/11.5
- 3,829,990 8/1974 Sakamoto ..... D21/72 X
- 3,930,322 1/1976 Endo ..... 36/11.5

OTHER PUBLICATIONS

*Shoe & Leather Reporter*-Date/N/A-p. 23-Sandal at bottom left.

*Primary Examiner*-Nelson C. Holtje  
*Attorney, Agent, or Firm*-D. Paul Weaver

[57] CLAIM

The ornamental design for an overshoe, as shown and described.

DESCRIPTION

FIG. 1 is a top and right front perspective view of an overshoe showing my new design;  
 FIG. 2 is a bottom and left front perspective view thereof;  
 FIG. 3 is a right side elevational view thereof;  
 FIG. 4 is a top plan view thereof;  
 FIG. 5 is a bottom plan view thereof.

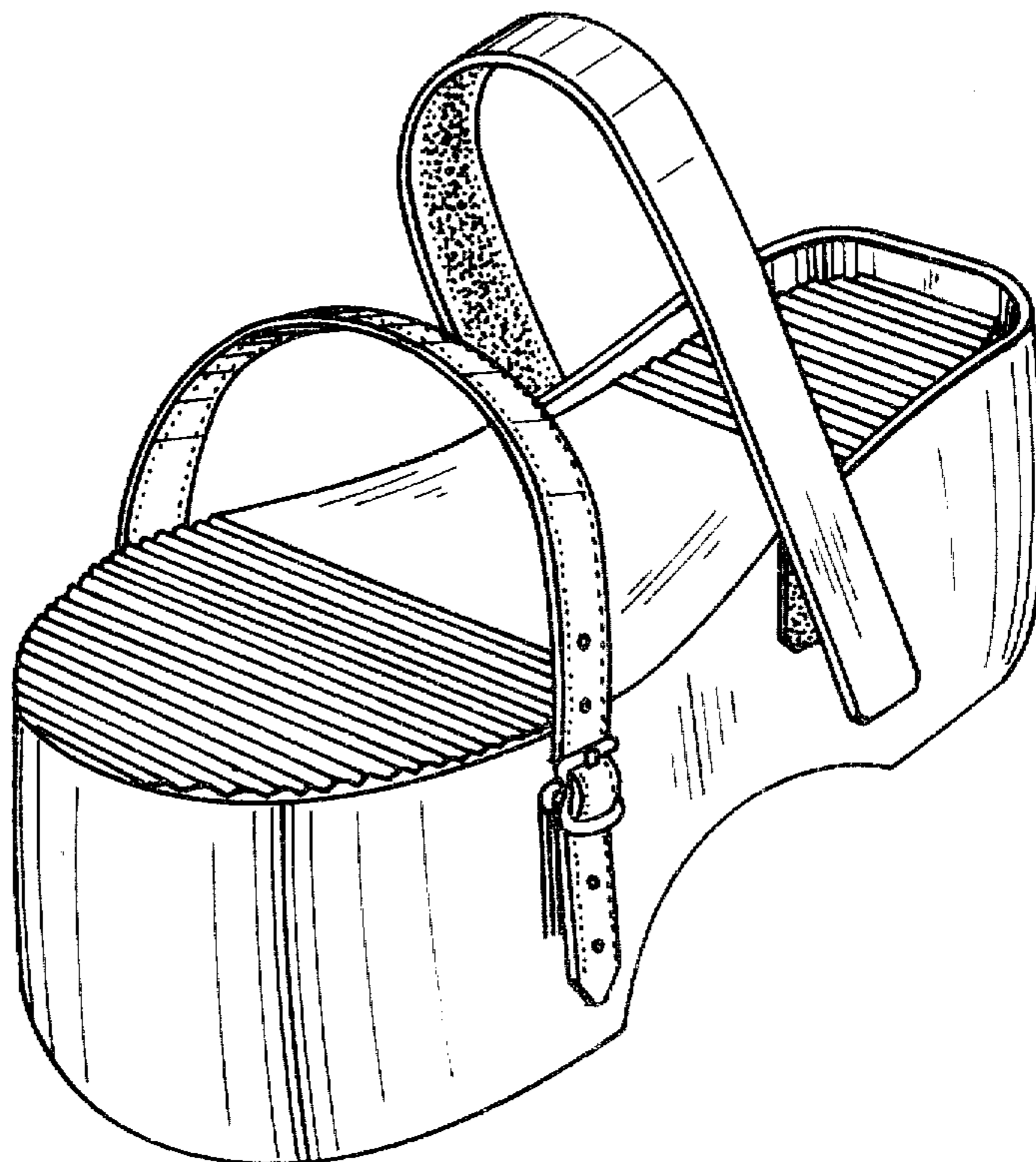

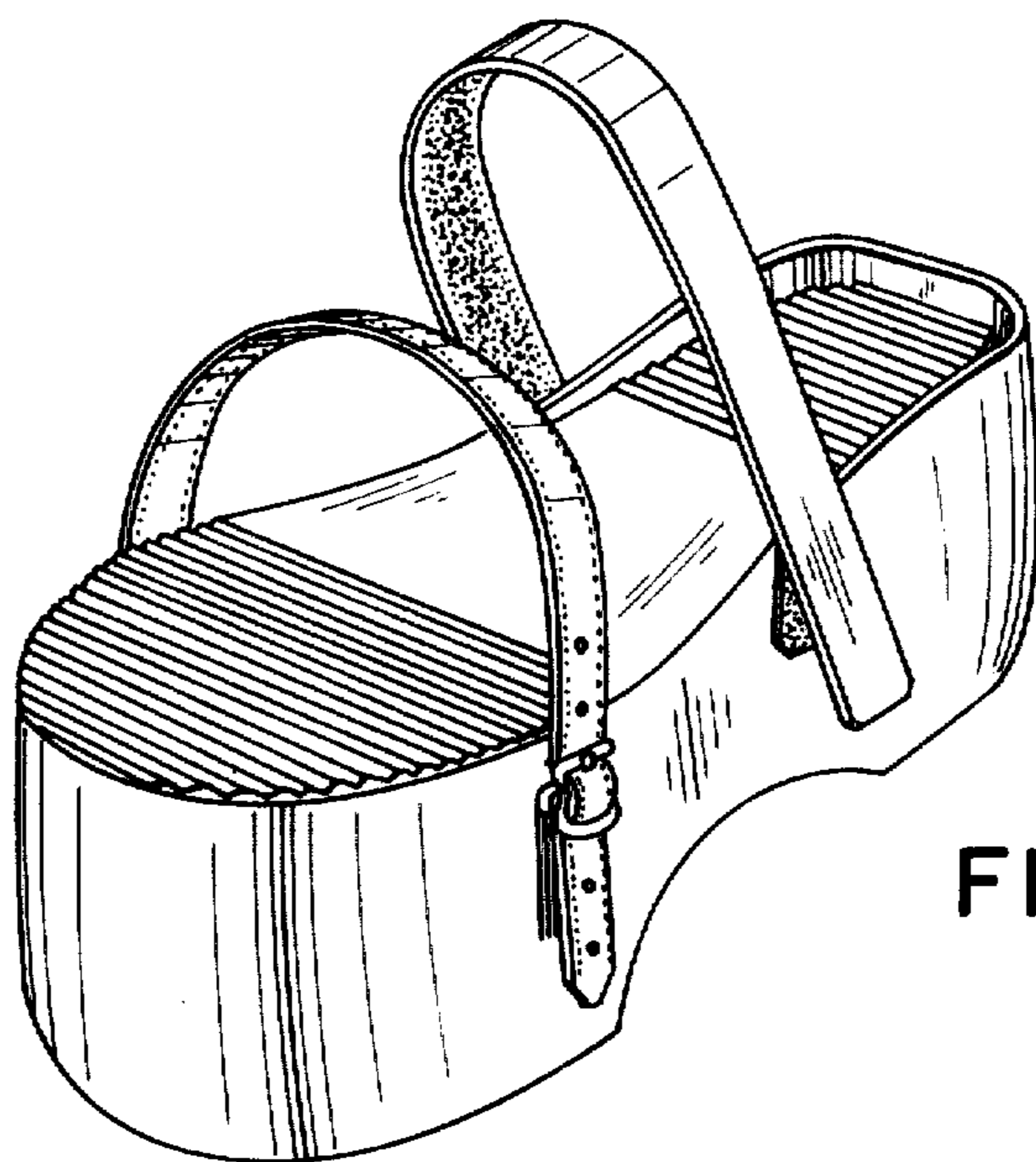

FIG. 1

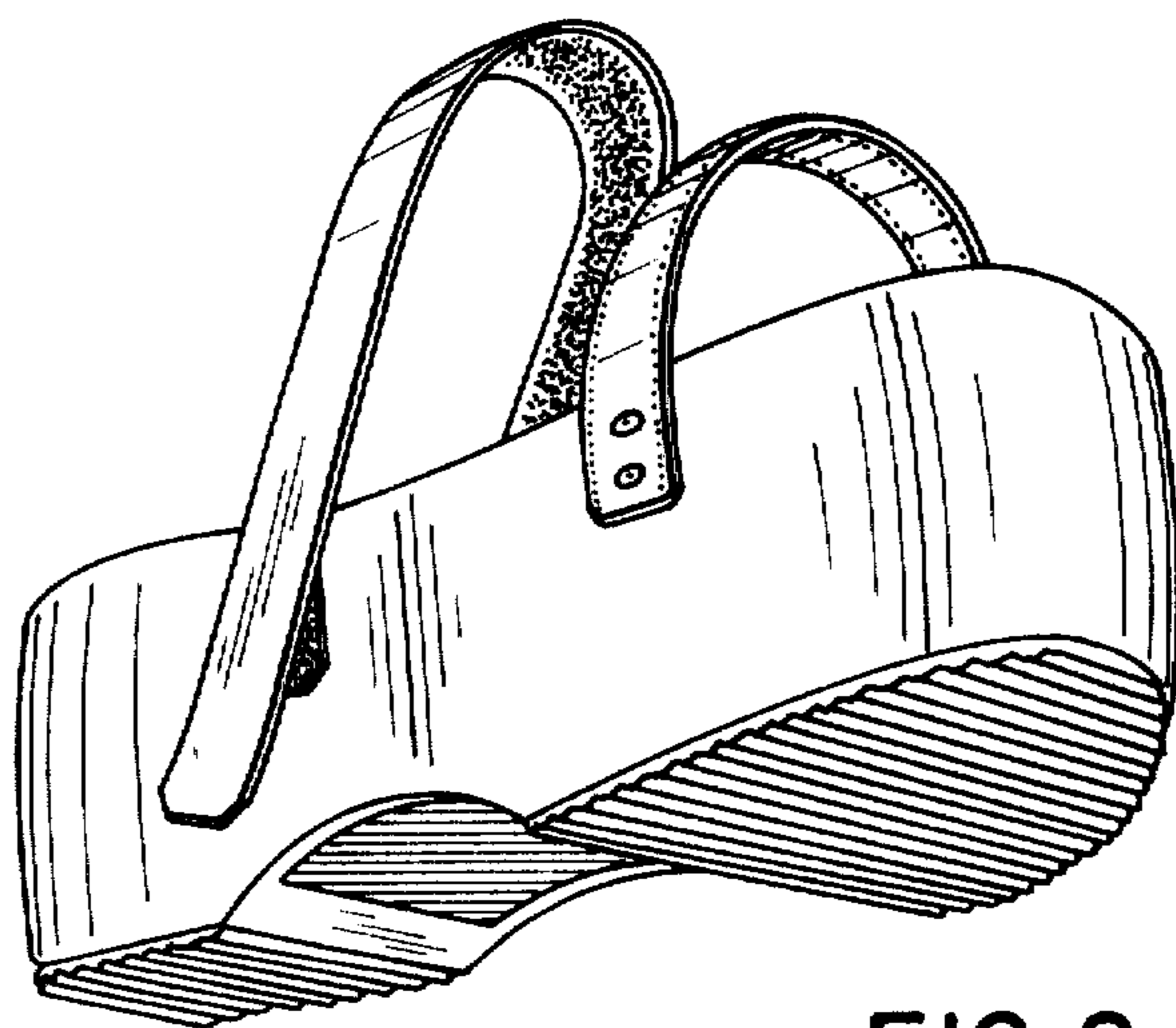

FIG. 2

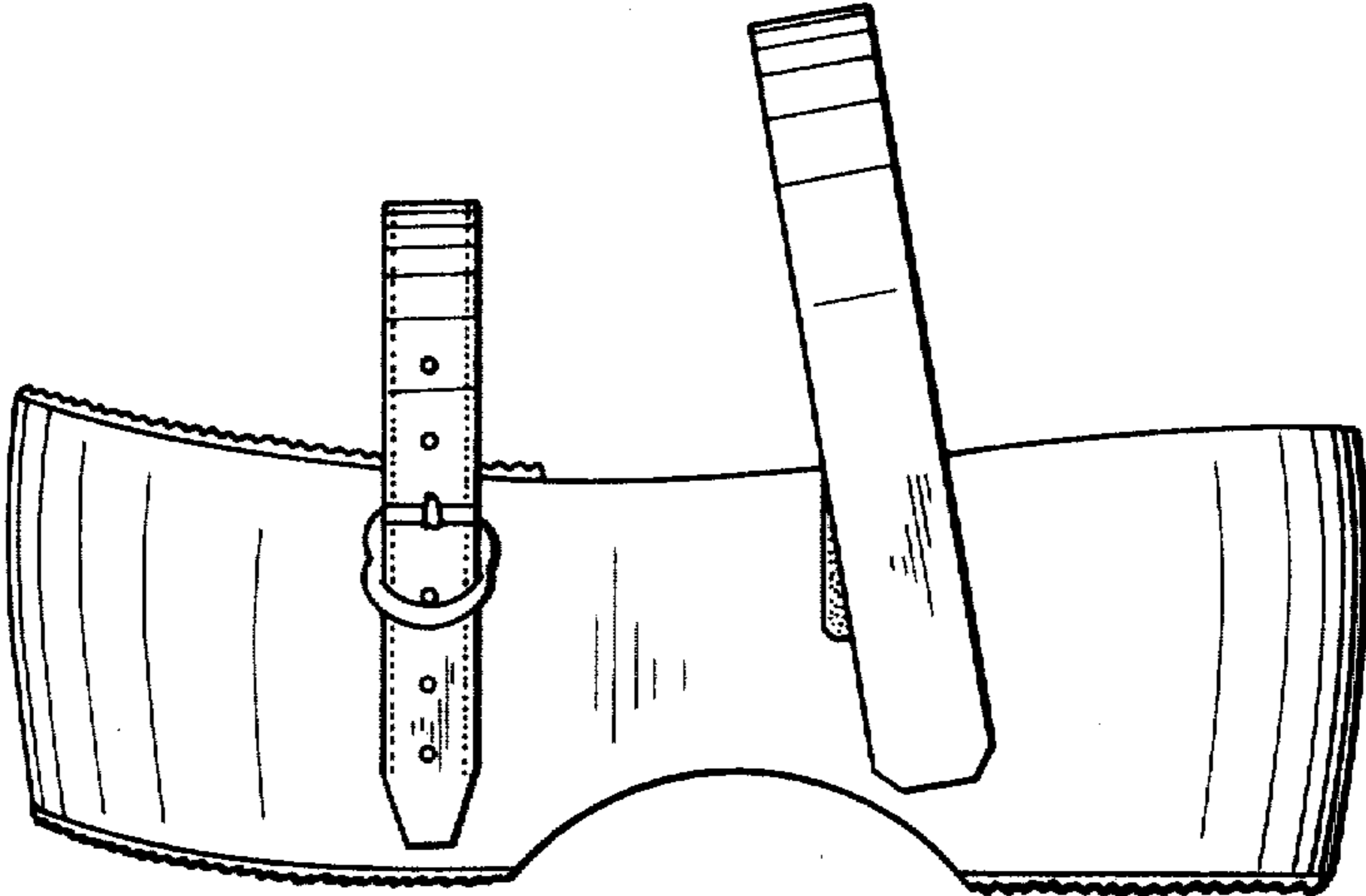

FIG. 3

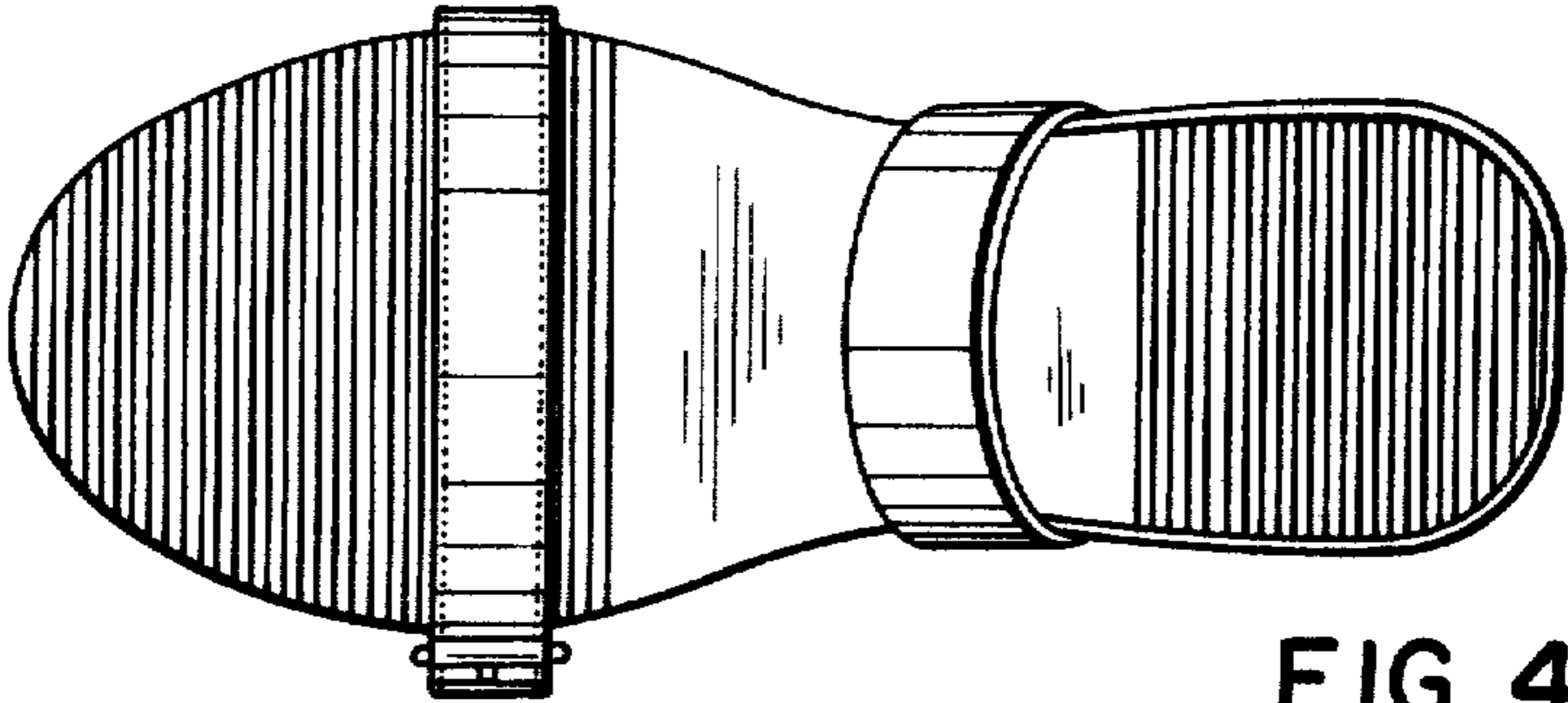

FIG. 4

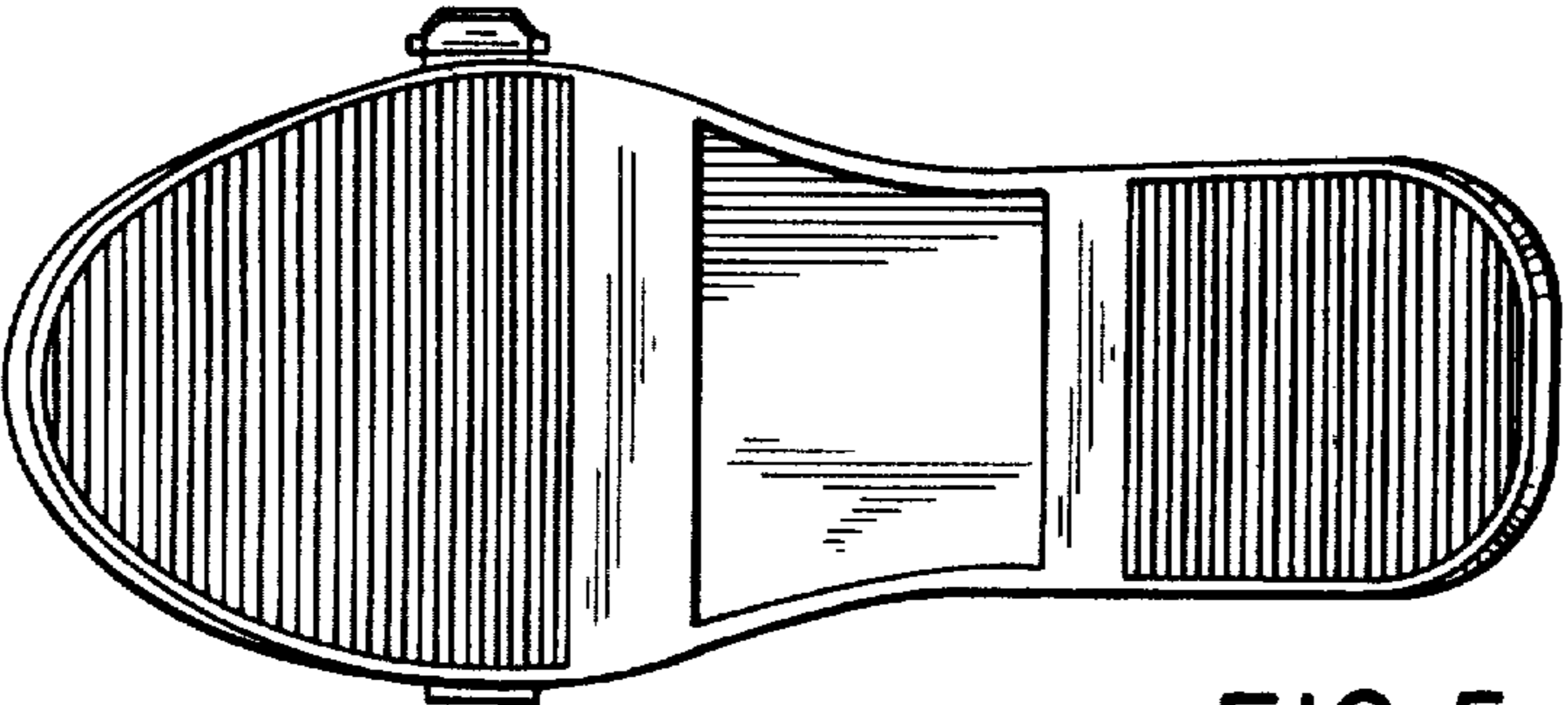

FIG. 5