

[54] COMBINED VEHICLE DASHBOARD AND CONSOLE UNIT

[75] Inventors: **Claus Luthe, Munich; Manfred Rennen, Ingolstadt; Hans Braun, Lohhof, all of Fed. Rep. of Germany**

[73] Assignee: **Bayerische Motoren Werke Aktiengesellschaft, Munich, Fed. Rep. of Germany**

[\*\*] Term: **14 Years**

[21] Appl. No.: **247,908**

[22] Filed: **Mar. 26, 1981**

[30] **Foreign Application Priority Data**

Sep. 30, 1980 [DE] Fed. Rep. of Germany ... MR 12 272

[51] Int. Cl. .... **D12-16**

[52] U.S. Cl. .... **D12/192**

[58] Field of Search ..... **D12/192; 180/90; 296/70**

[56] **References Cited PUBLICATIONS**

Austro Motor, 4/79, p. 153, Dashboard & Console, top right side of page.

AustroMotor, 6/79, p. 263, Dashboard & Console, top right side of page.

Austro Motor, 9/79, p. 374, Dashboard & Console, bottom right side of page.

Austro Motor, 10/79, p. 419, Dashboard & Console, bottom left side of page.

*Primary Examiner*—James M. Gandy  
*Attorney, Agent, or Firm*—Craig & Burns

[57] **CLAIM**

The ornamental design for a combined vehicle dashboard and console unit, substantially as shown and described.

**DESCRIPTION**

FIG. 1 is a perspective view from the front and to the left side of the combined vehicle dashboard and console unit showing my new design;

FIG. 2 is a front elevational view thereof;

FIG. 3 is a perspective view thereof from the front and to the right side thereof;

FIG. 4 is a top plan view thereof;

FIG. 5 is a right-side elevational view thereof; and

FIG. 6 is a left-side elevational view thereof.

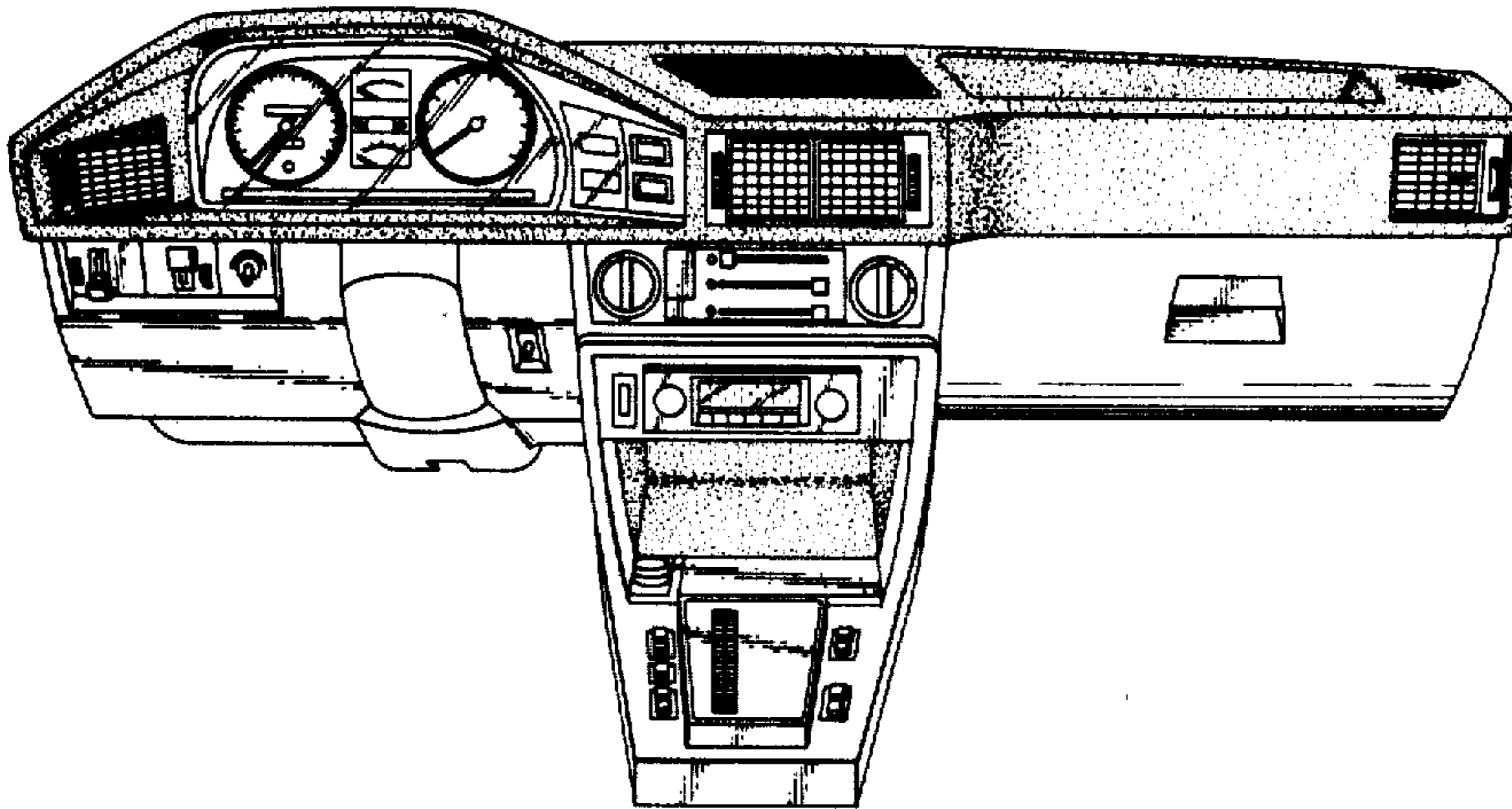

FIG. 1.

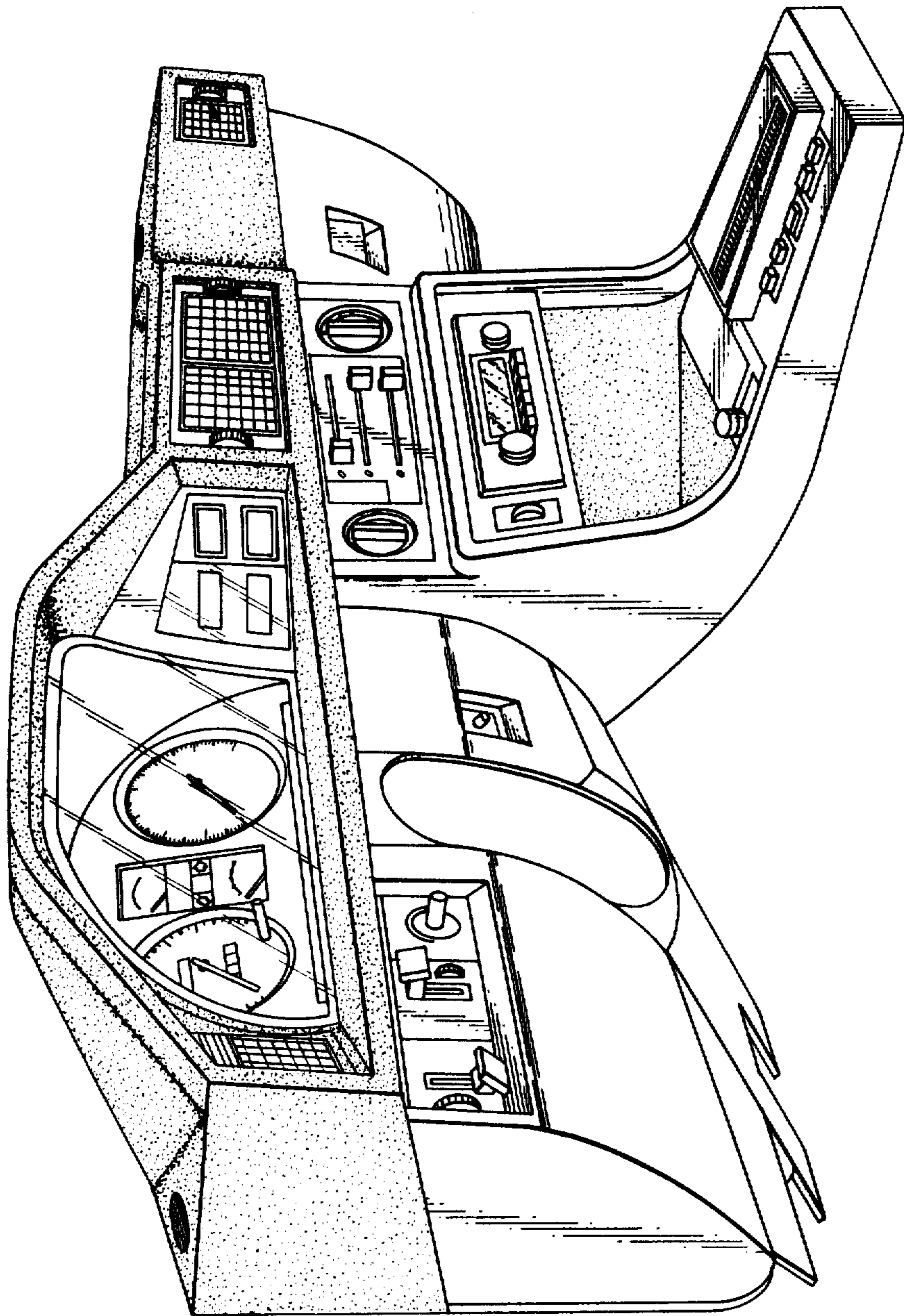

FIG. 2.

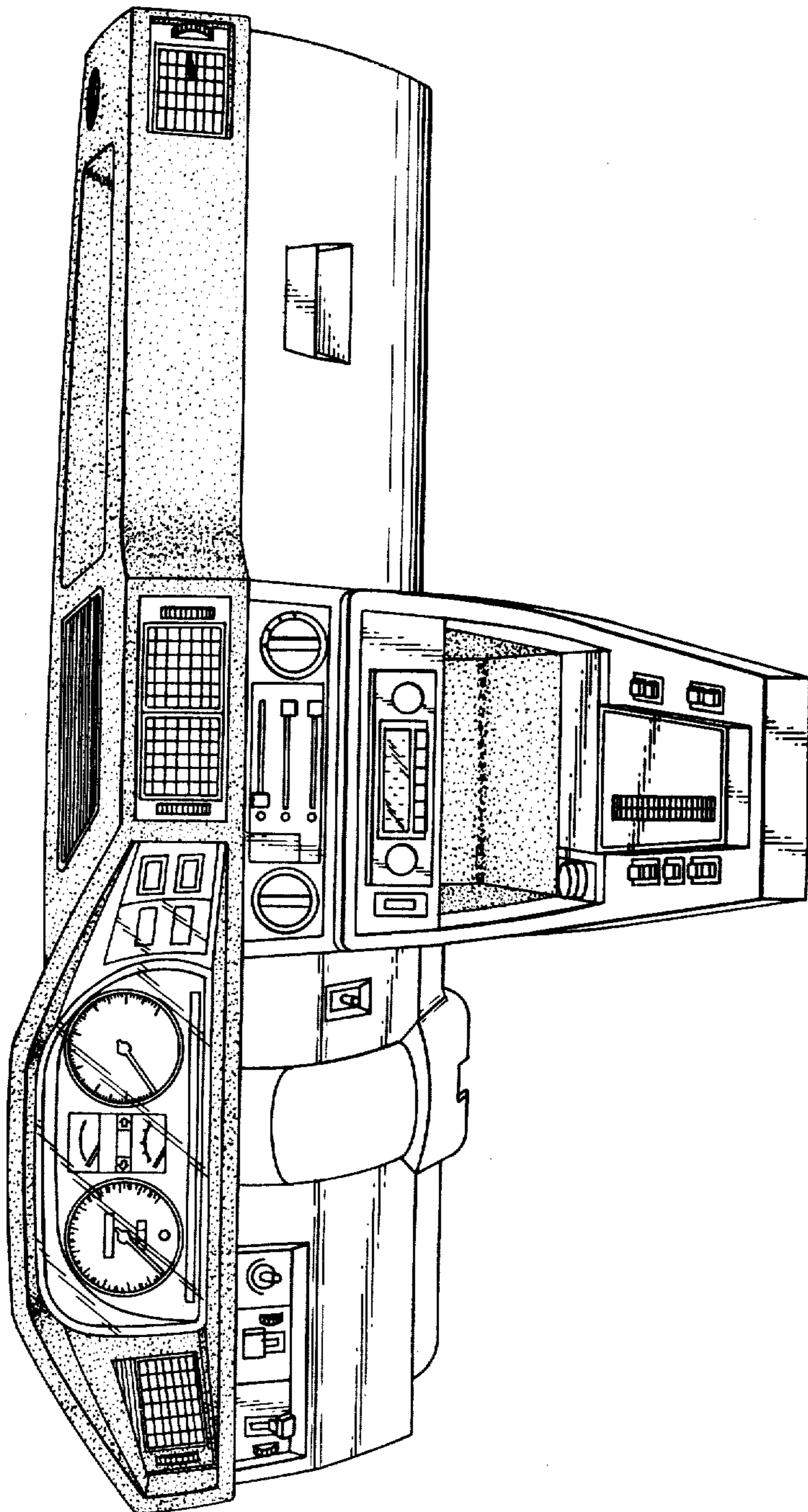

FIG. 3.

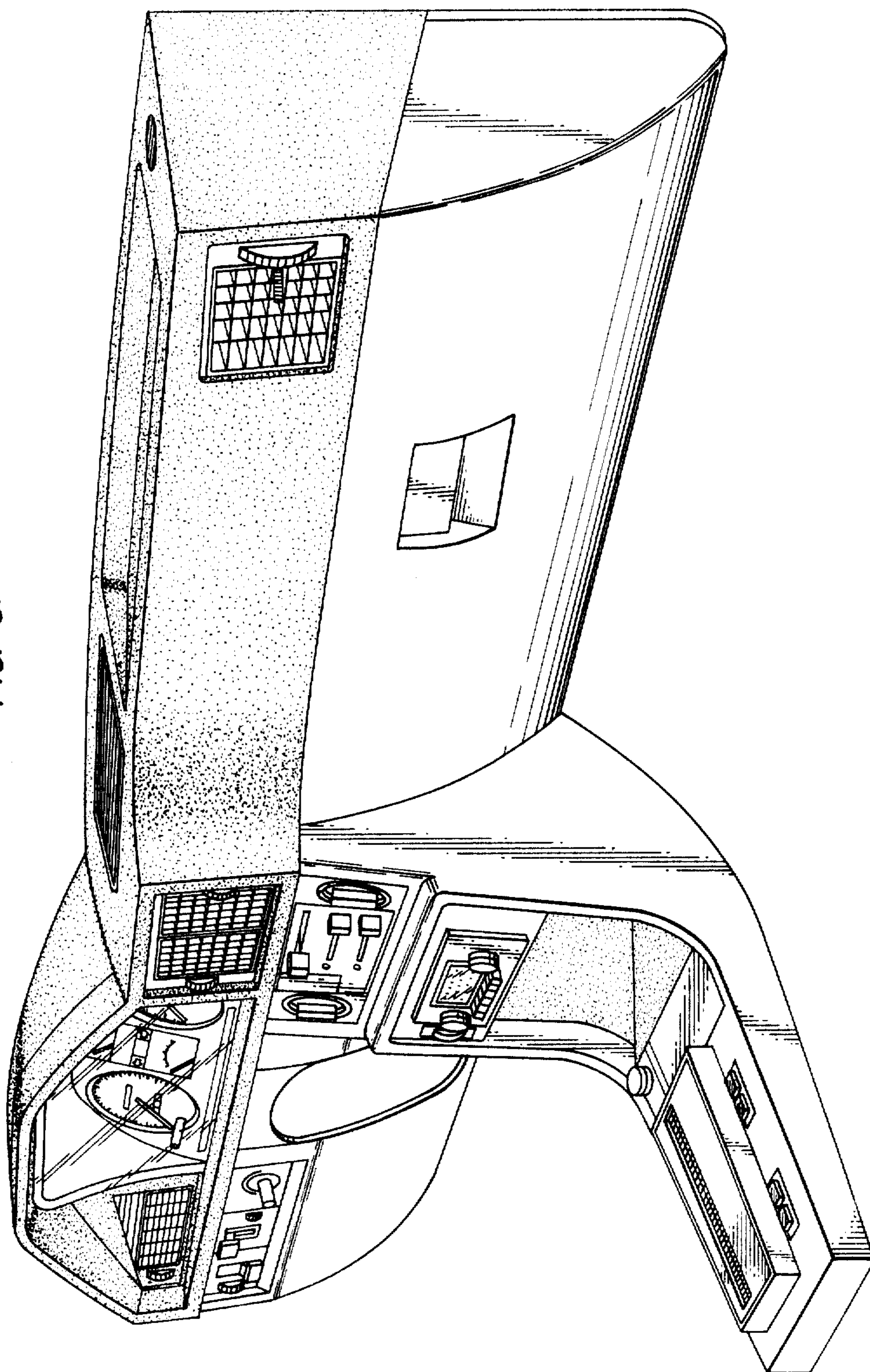

FIG. 4.

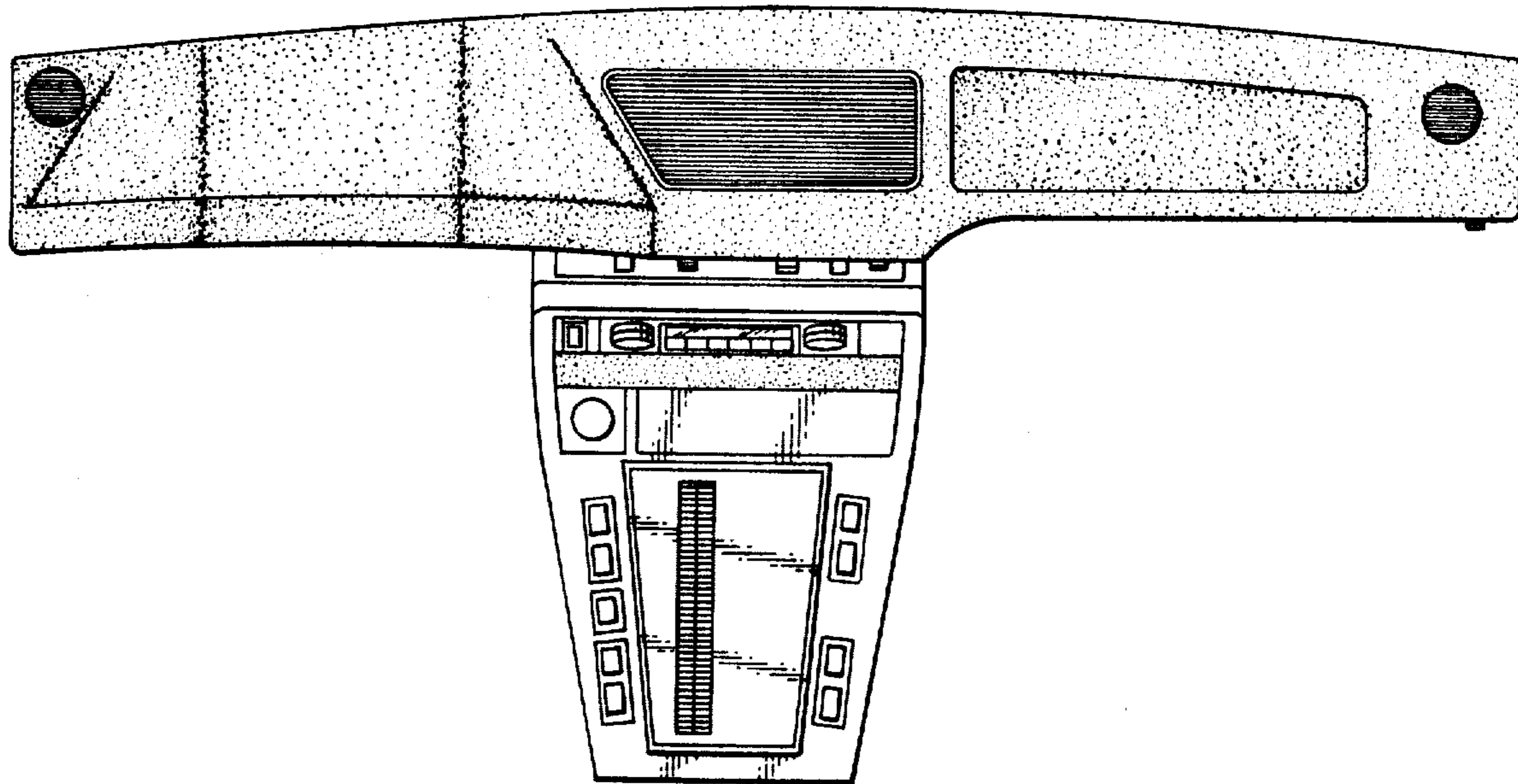

FIG. 5.

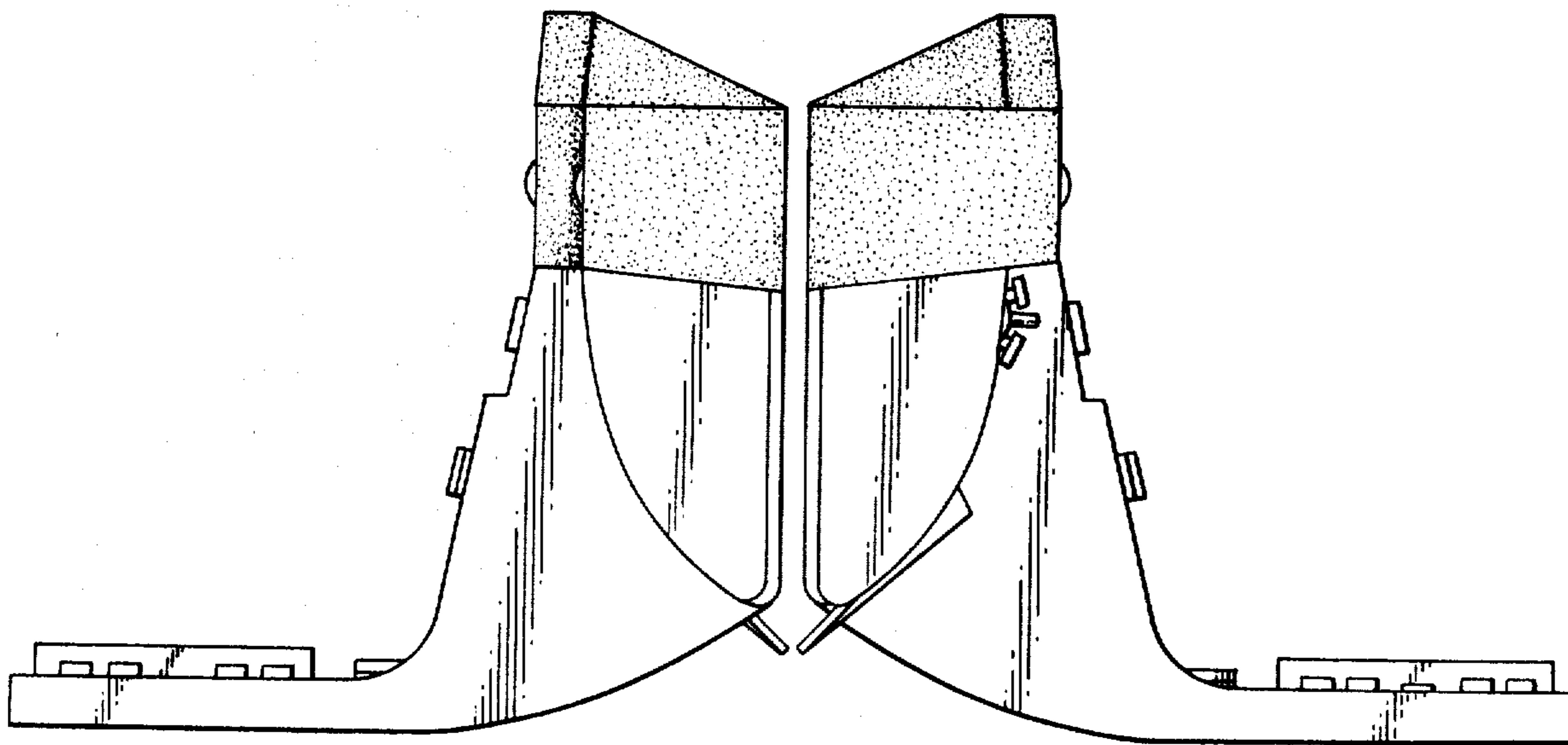

FIG. 6.