

[54] TRAILER

[75] Inventor: Clarence Triggs, Belmond, Iowa

[73] Assignee: Triggs Manufacturing Company, Belmond, Iowa

[**] Term: 14 Years

[21] Appl. No.: 271,196

[22] Filed: Jun. 8, 1981

[51] Int. Cl. D12-10

[52] U.S. Cl. D12/102

[58] Field of Search D12/102, 103, 105; 119/7, 15; 280/400, 423 B, 63; 296/24 C, 181

[56] References Cited

U.S. PATENT DOCUMENTS

D. 85,816 12/1931 Curtiss D12/103

OTHER PUBLICATIONS

Implement & Tractor, 1/7/75, p. 23, Trailer No. 4, lower left side of page.

Primary Examiner—James M. Gandy
Attorney, Agent, or Firm—Zarley, McKee, Thomte, Voorhees & Sease

[57] CLAIM

The ornamental design for a trailer, substantially as shown and described.

DESCRIPTION

FIG. 1 is a frontal perspective view of a trailer embodying my new design;
FIG. 2 is a top plan view thereof;
FIG. 3 is a front elevational view thereof;
FIG. 4 is a side elevational view thereof, and the opposite side is a mirror image of that shown; and
FIG. 5 is a rear elevational view thereof.

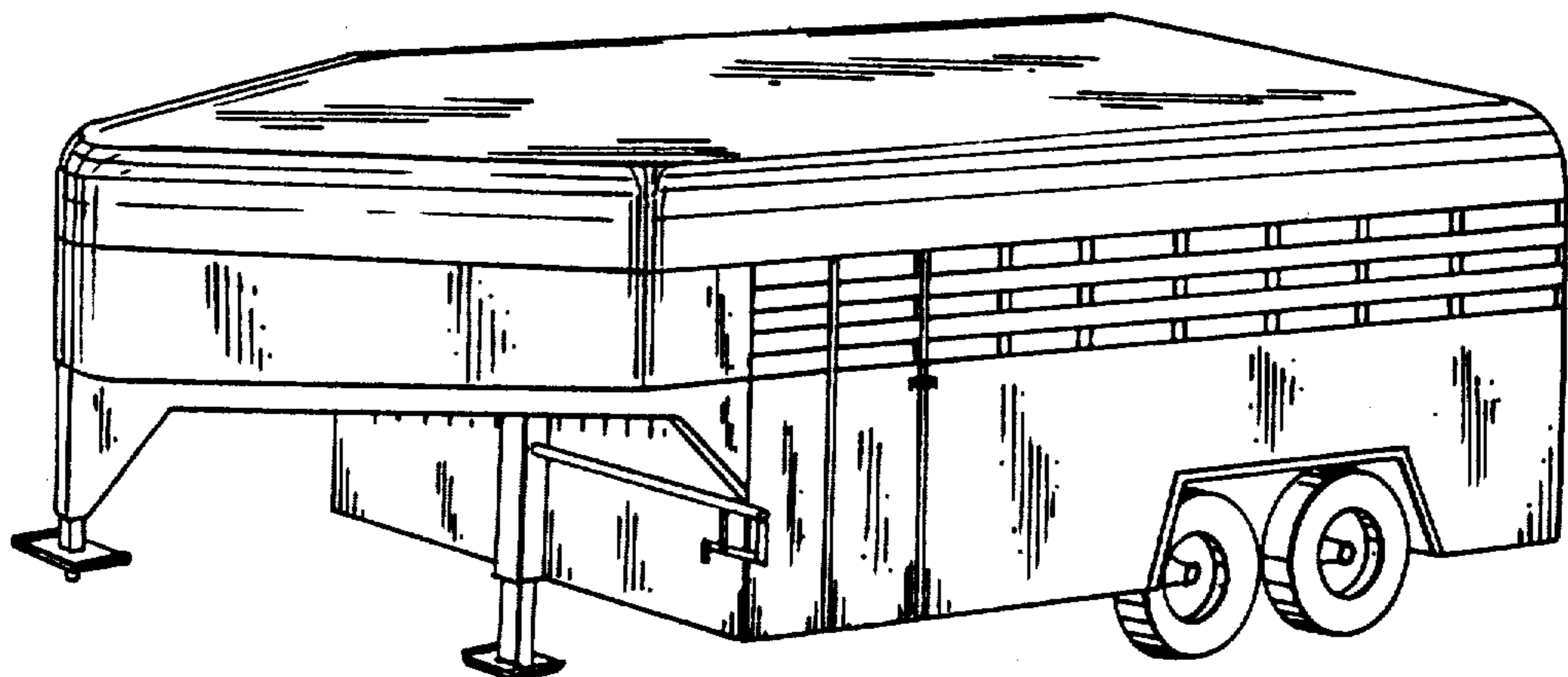

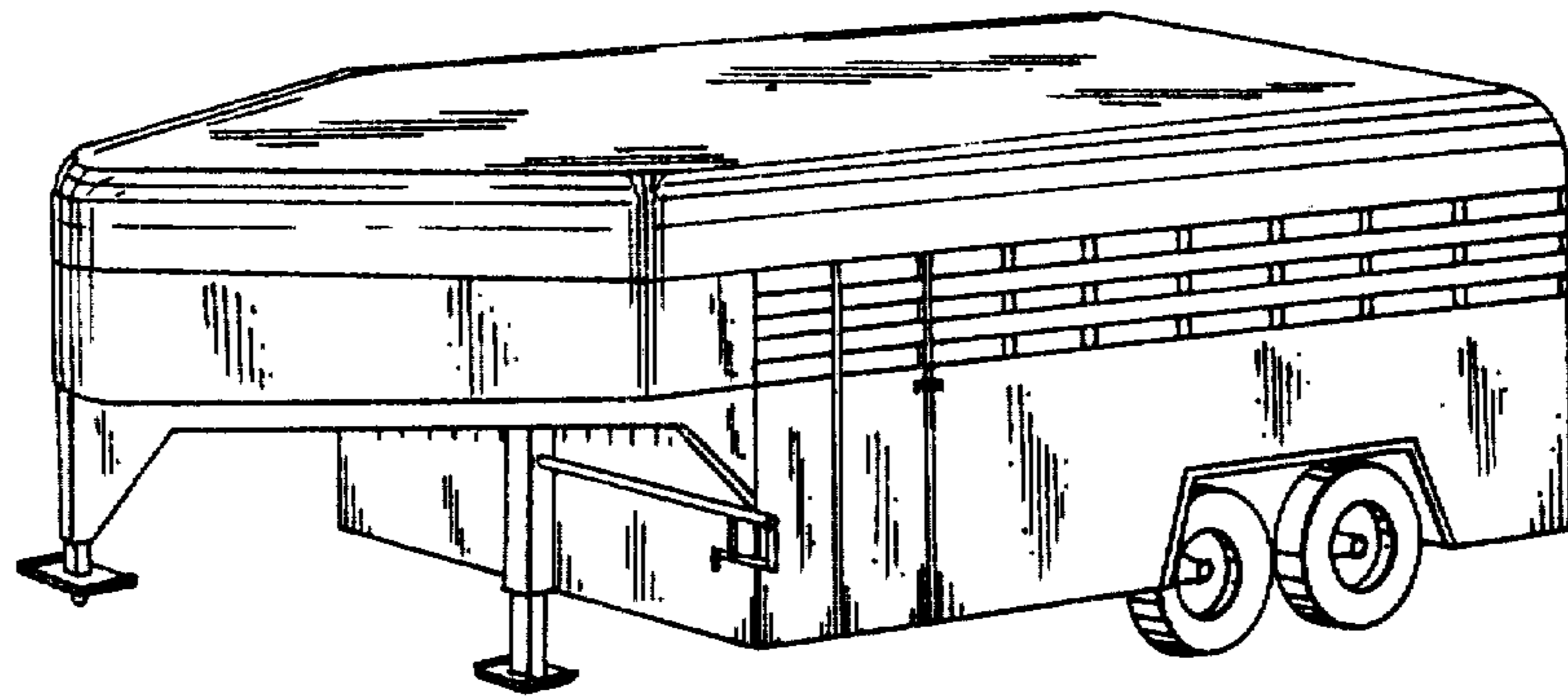

Fig. 1

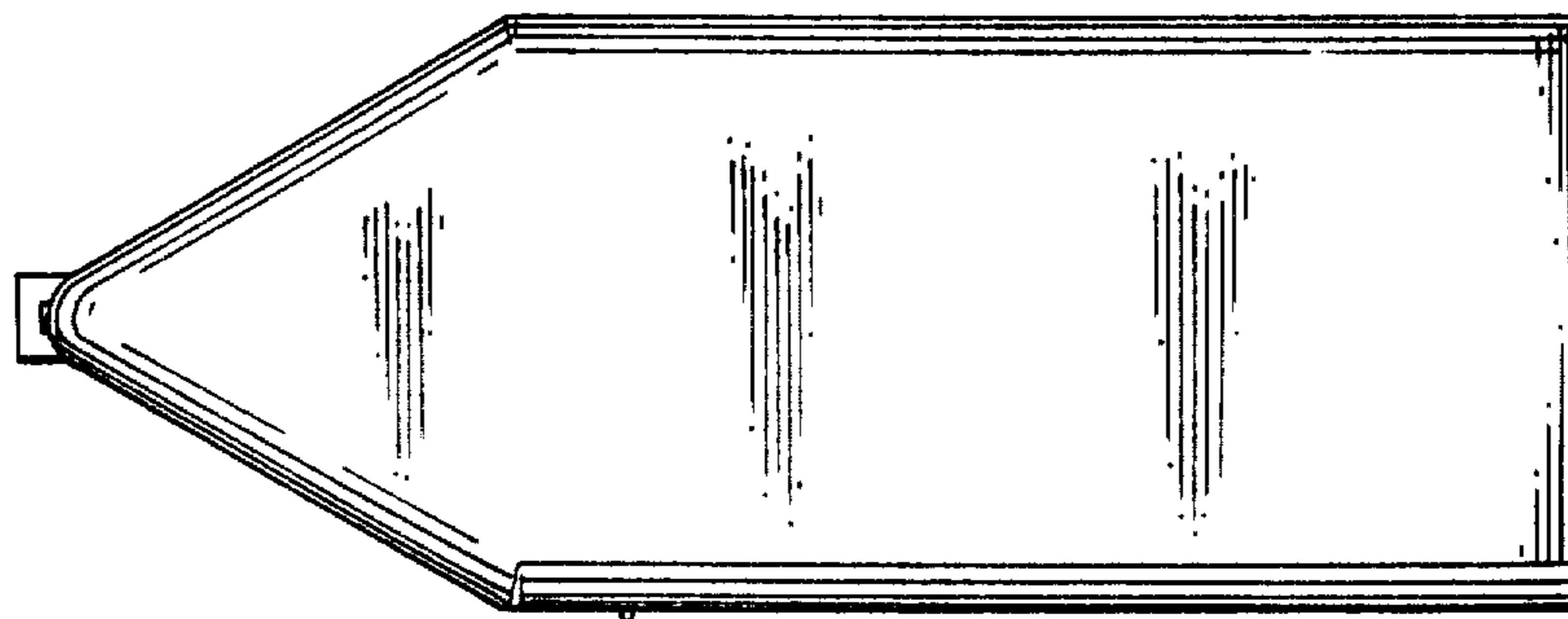

Fig. 2

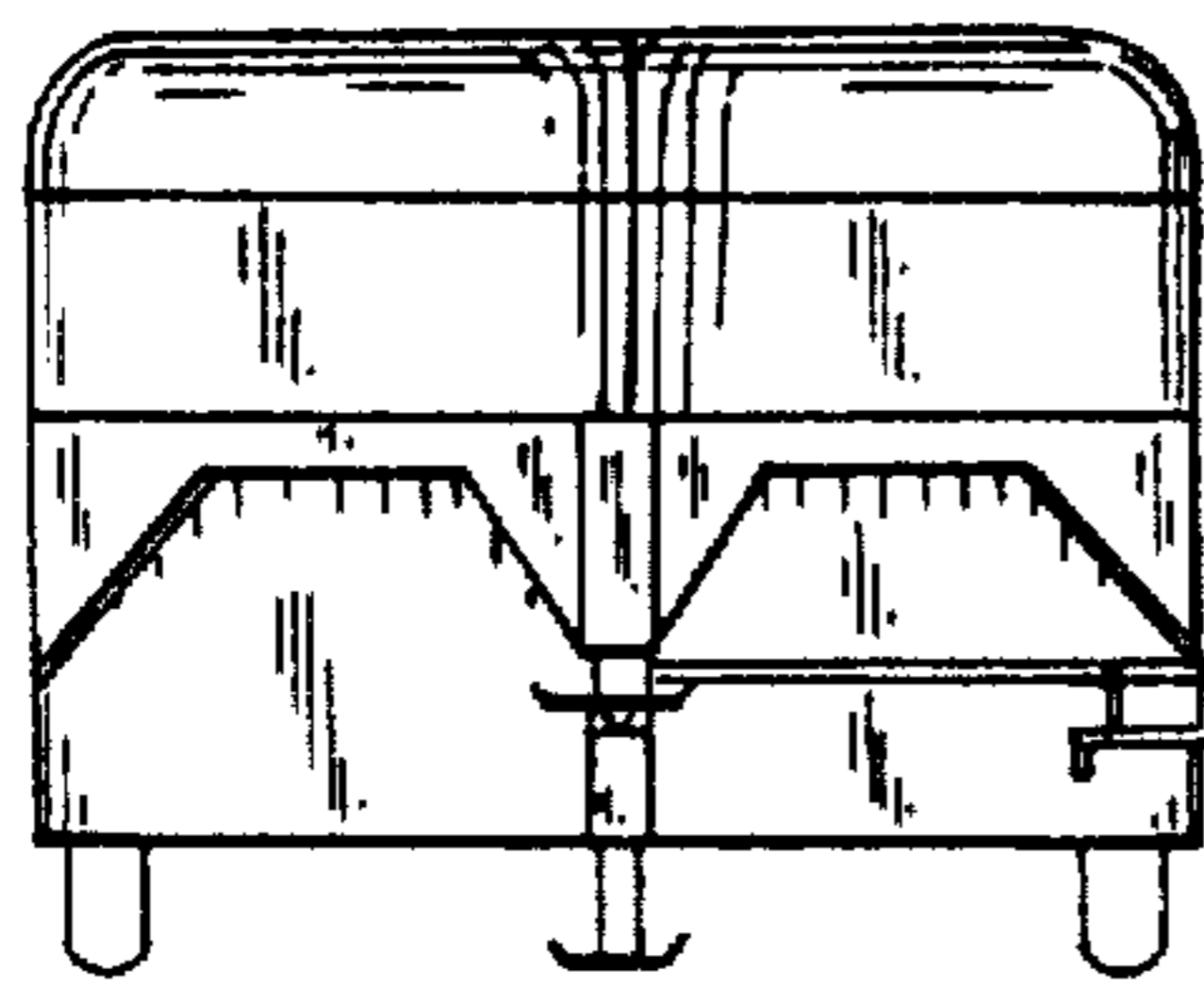

Fig. 3

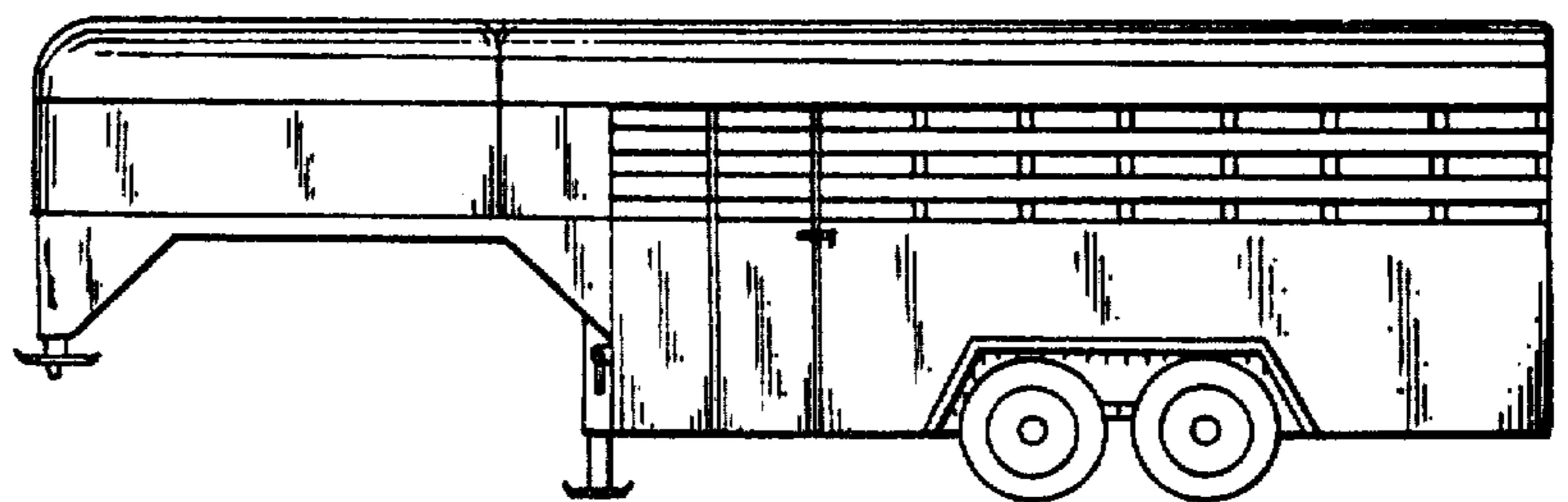

Fig. 4

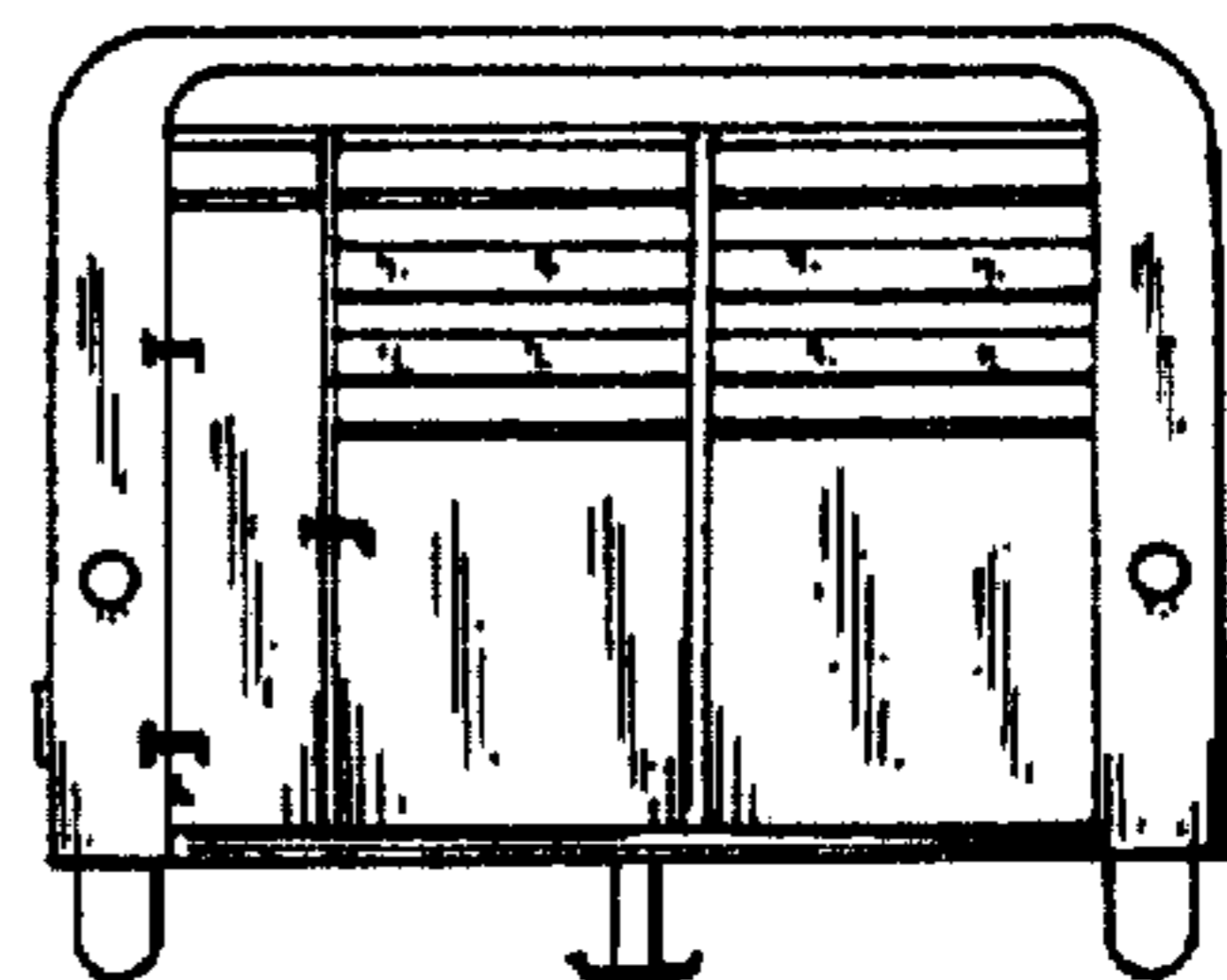

Fig. 5