

[54] PAIR OF COMBINED SAFETY BAR AND FOOT RESTS FOR A MOTOR CYCLE

[76] Inventor: James O'Rourke, Unit 4, 8131 Keele St., Concord, Ontario, Canada, L4K 1C8

[**] Term: 14 Years

[21] Appl. No.: 293,796

[22] Filed: Aug. 18, 1981

[30] Foreign Application Priority Data

Mar. 20, 1981 [CA] Canada 20-03-81-1

[51] Int. Cl. D12-11

[52] U.S. Cl. D12/114

[58] Field of Search D12/114; 280/289 G, 280/291

[56] References Cited

PUBLICATIONS

J. C. Whitney Motorcycle Parts & Accessories Catalog No. 10A, ©1975, p. 27, Foot Boards, top left side of page.

J. C. Whitney Motorcycle Parts & Accessories Catalog

No. 10A, ©1975, p. 27, Rear Safety Bars, lower right side of page.

J. C. Whitney Catalog No. 392B, ©1979, p. 157, Front Highway Safety Bar Combination, top left side of page.

Primary Examiner—James M. Gandy

Attorney, Agent, or Firm—Robert F. Delbridge; Arne I. Fors

[57] CLAIM

The ornamental design for a pair of combined safety bar and foot rests for a motor cycle, as shown and described.

DESCRIPTION

FIG. 1 is a perspective view of a pair of combined safety bar and foot rests for a motor cycle showing my new design;

FIG. 2 is a front elevational view thereof;

FIG. 3 is a top plan view thereof;

FIG. 4 is a side elevational view thereof; and

FIG. 5 is a perspective view of one of the pairs of combined safety bar and foot rests shown in association with a motor cycle which is set forth in broken lines for illustrative purposes only.

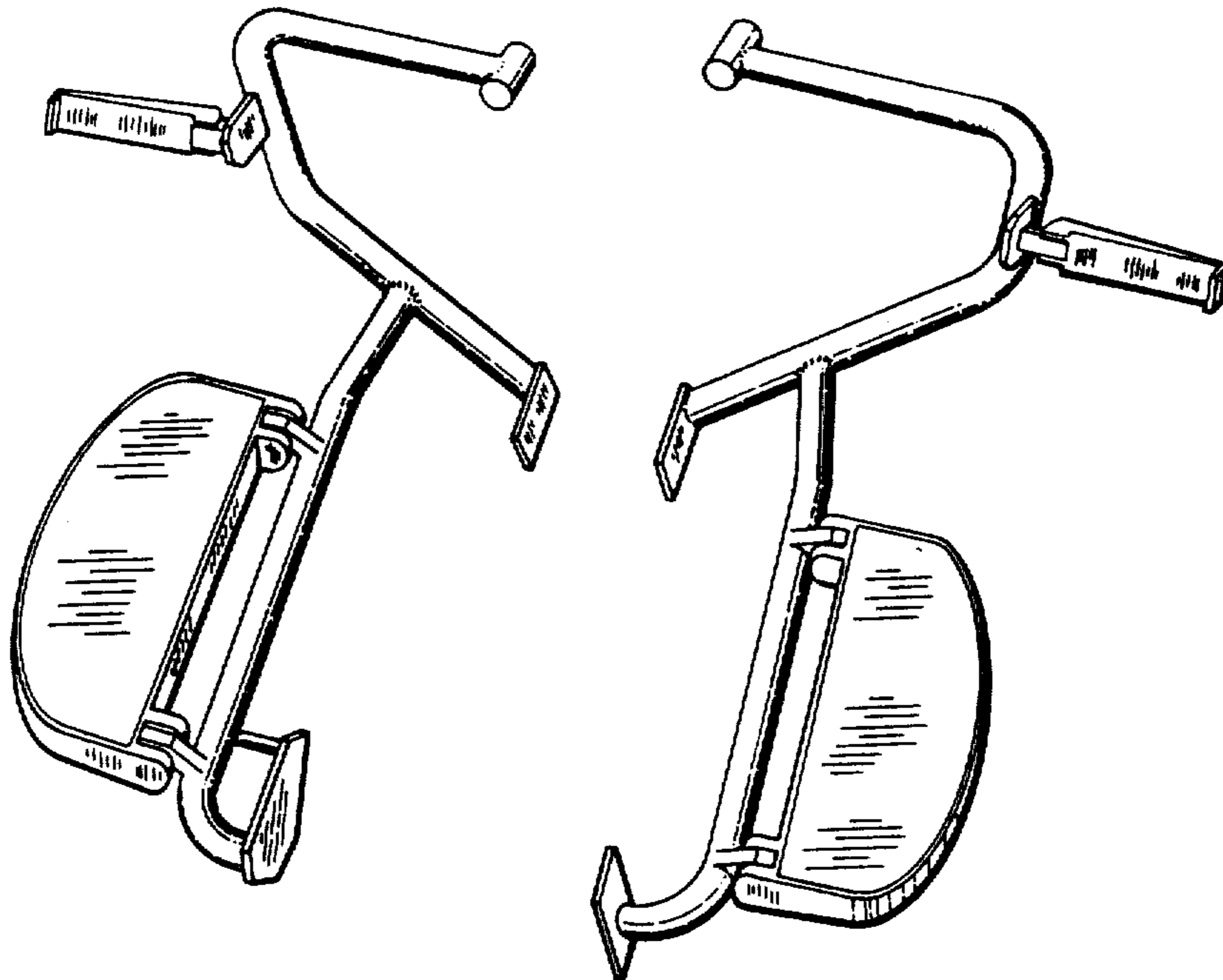

FIG. 1.

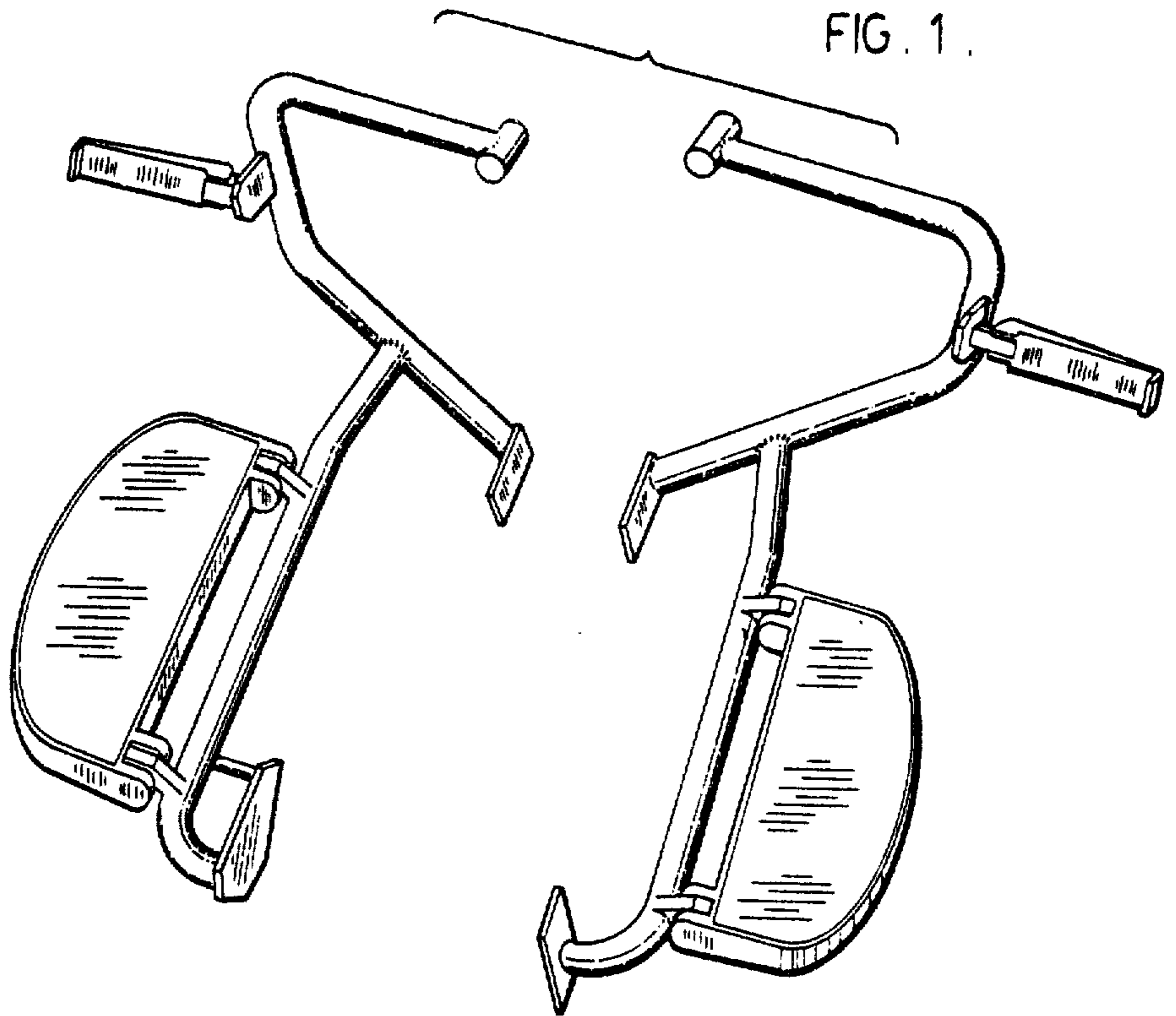
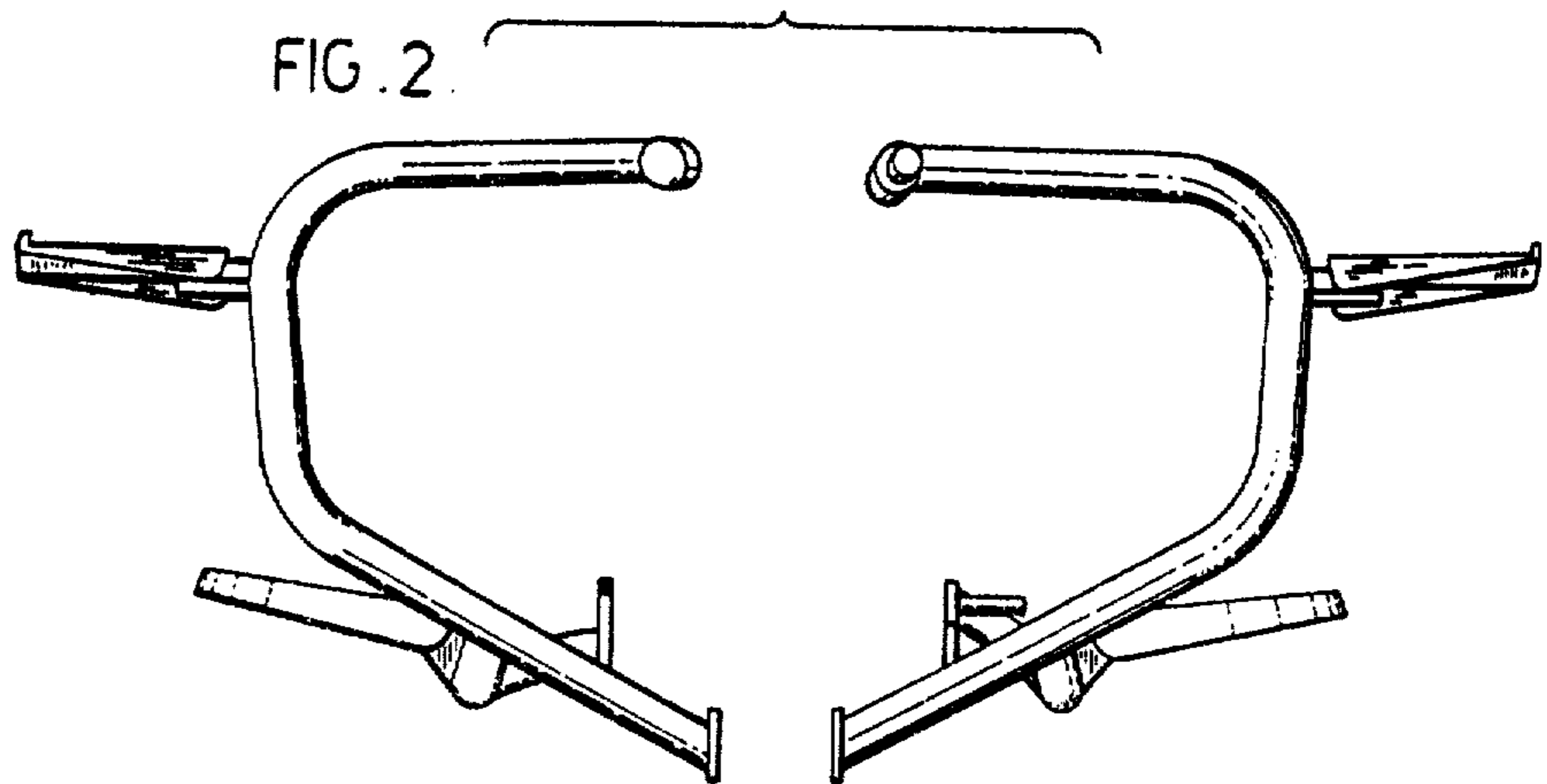

FIG. 2.



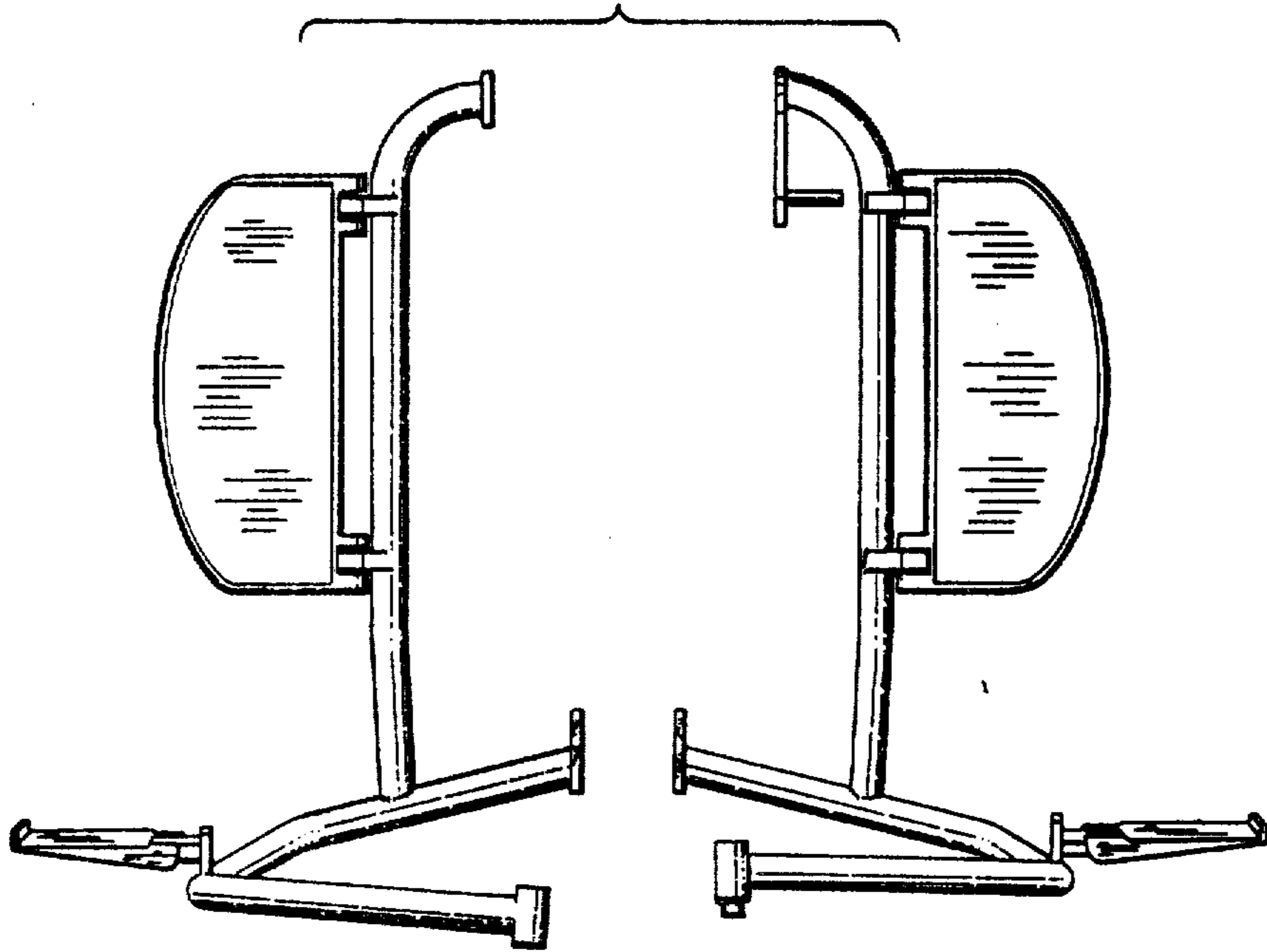

FIG. 3.

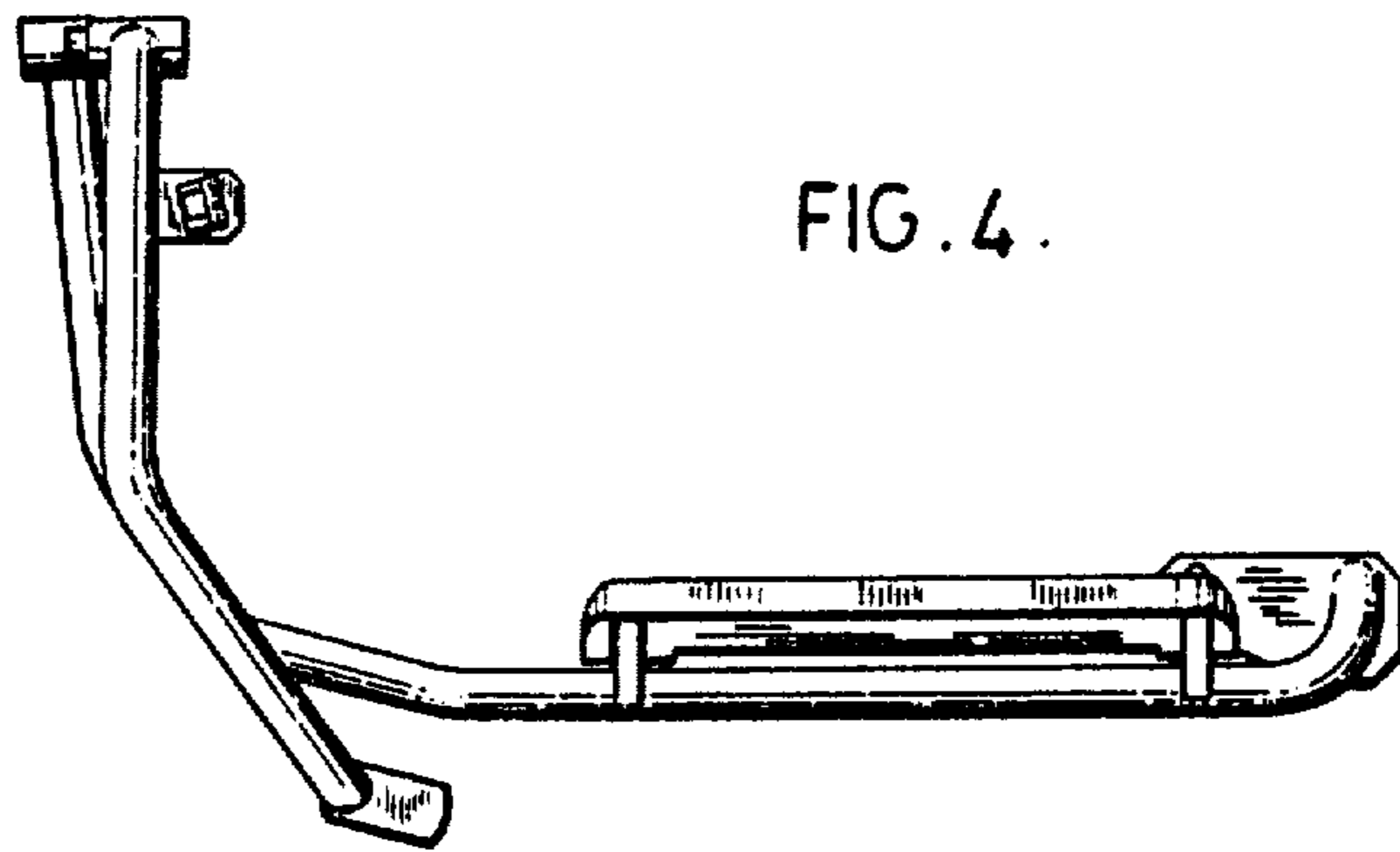

FIG. 4.

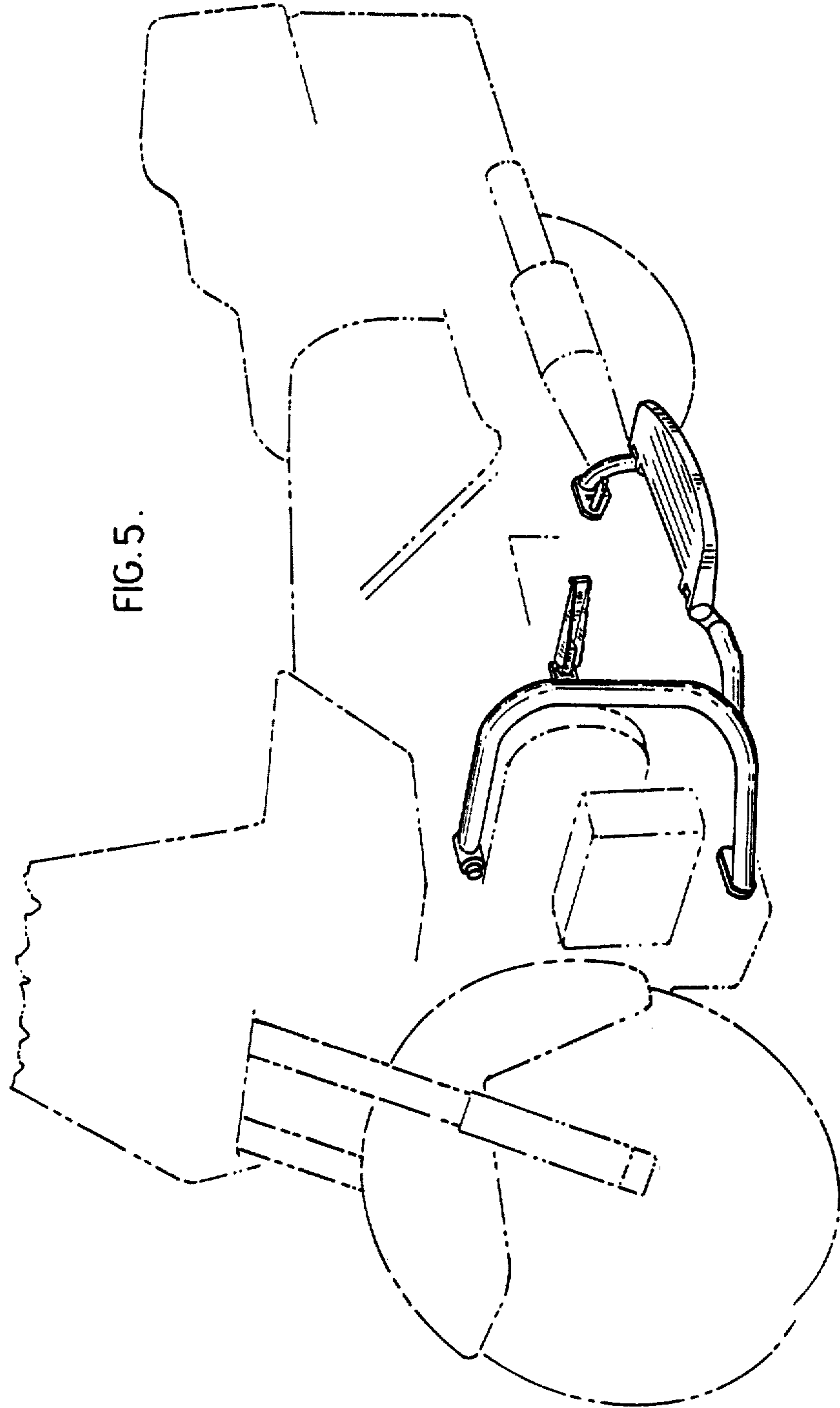

FIG. 5.