

[54] **MOTORCYCLE**

[75] **Inventor:** Klaus V. Gevert, Munich, Fed. Rep. of Germany

[73] **Assignee:** Bayerische Motoren Werke Aktiengesellschaft, Munich, Fed. Rep. of Germany

[\*\*] **Term:** 14 Years

[21] **Appl. No.:** 220,243

[22] **Filed:** Dec. 23, 1980

[30] **Foreign Application Priority Data**

Jul. 1, 1980 [DE] Fed. Rep. of Germany ... MR 12182

[51] **Int. Cl.** ..... D12-11

[52] **U.S. Cl.** ..... D12/110

[58] **Field of Search** ..... D12/110; 180/219

[56] **References Cited**

**U.S. PATENT DOCUMENTS**

D. 262,445 12/1981 Ogishima ..... D12/110

**OTHER PUBLICATIONS**

Cycle World, 6/79, p. 125, Suzuki SP-370, bottom of page.

Cycle World, 6/80, p. 57, Yamaha XT250, top of page.

*Primary Examiner*—James M. Gandy  
*Attorney, Agent, or Firm*—Craig & Burns

[57] **CLAIM**

The ornamental design for a motorcycle, substantially as shown and described.

**DESCRIPTION**

FIG. 1 is a side perspective view of a motorcycle showing my new design;

FIG. 2 is a side perspective view thereof opposite to that shown in FIG. 1;

FIG. 3 is a perspective view of the front and side shown in FIG. 1;

FIG. 4 is a perspective view of the front and side shown in FIG. 2;

FIG. 5 is a front perspective view thereof;

FIG. 6 is a rear perspective view thereof;

FIG. 7 is a top perspective view thereof; and

FIG. 8 is a bottom perspective view thereof.

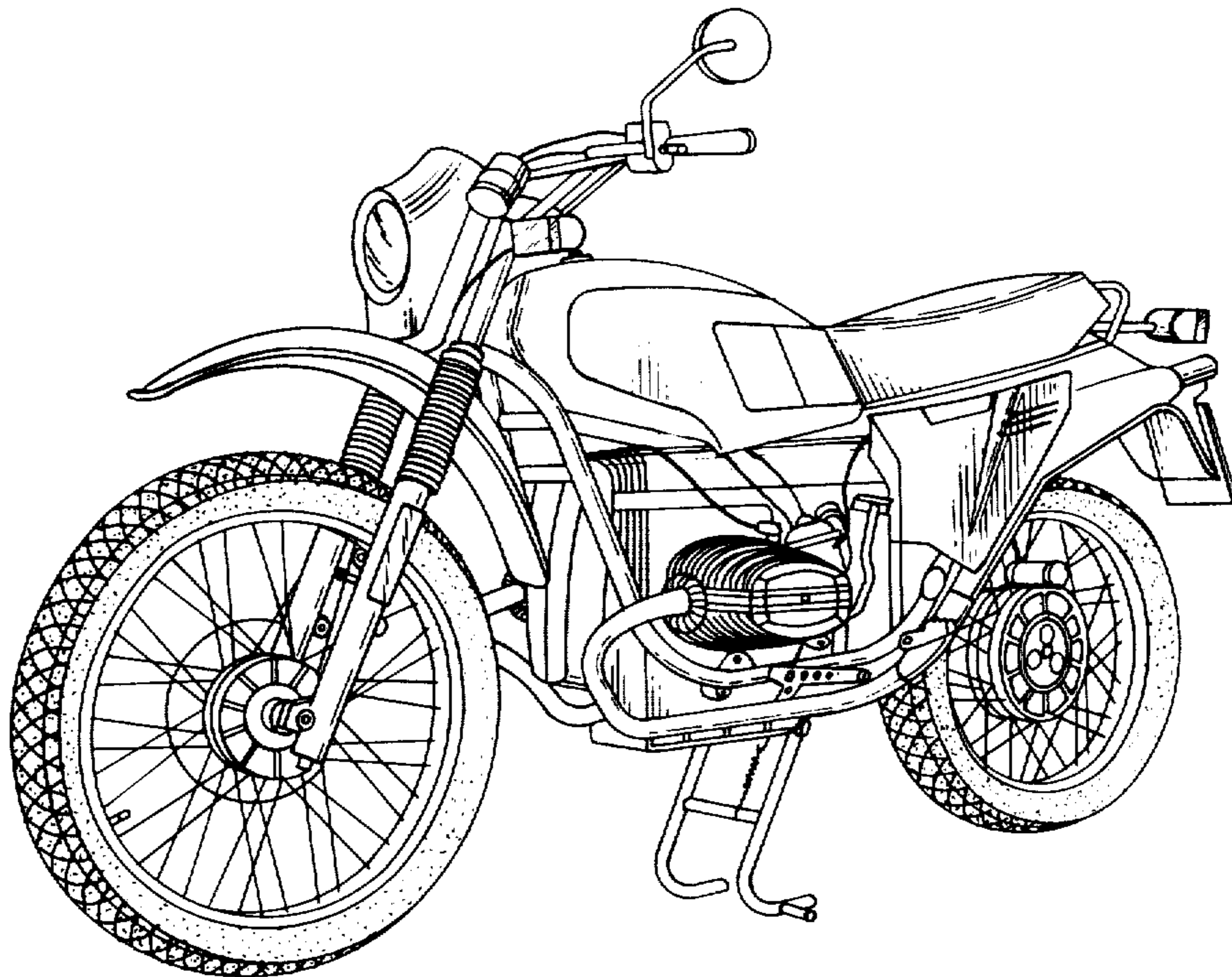

FIG. 1.

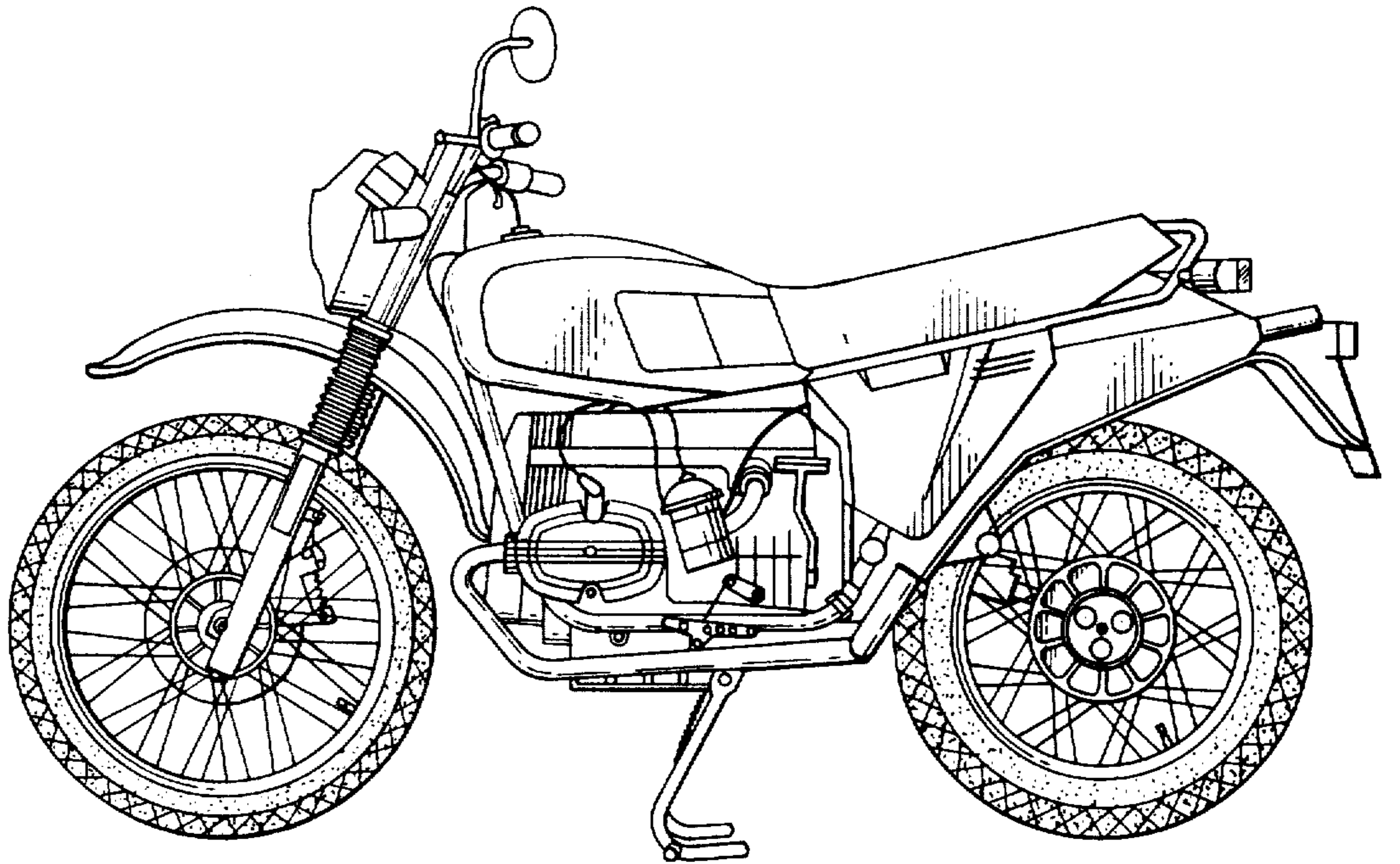

FIG. 2.

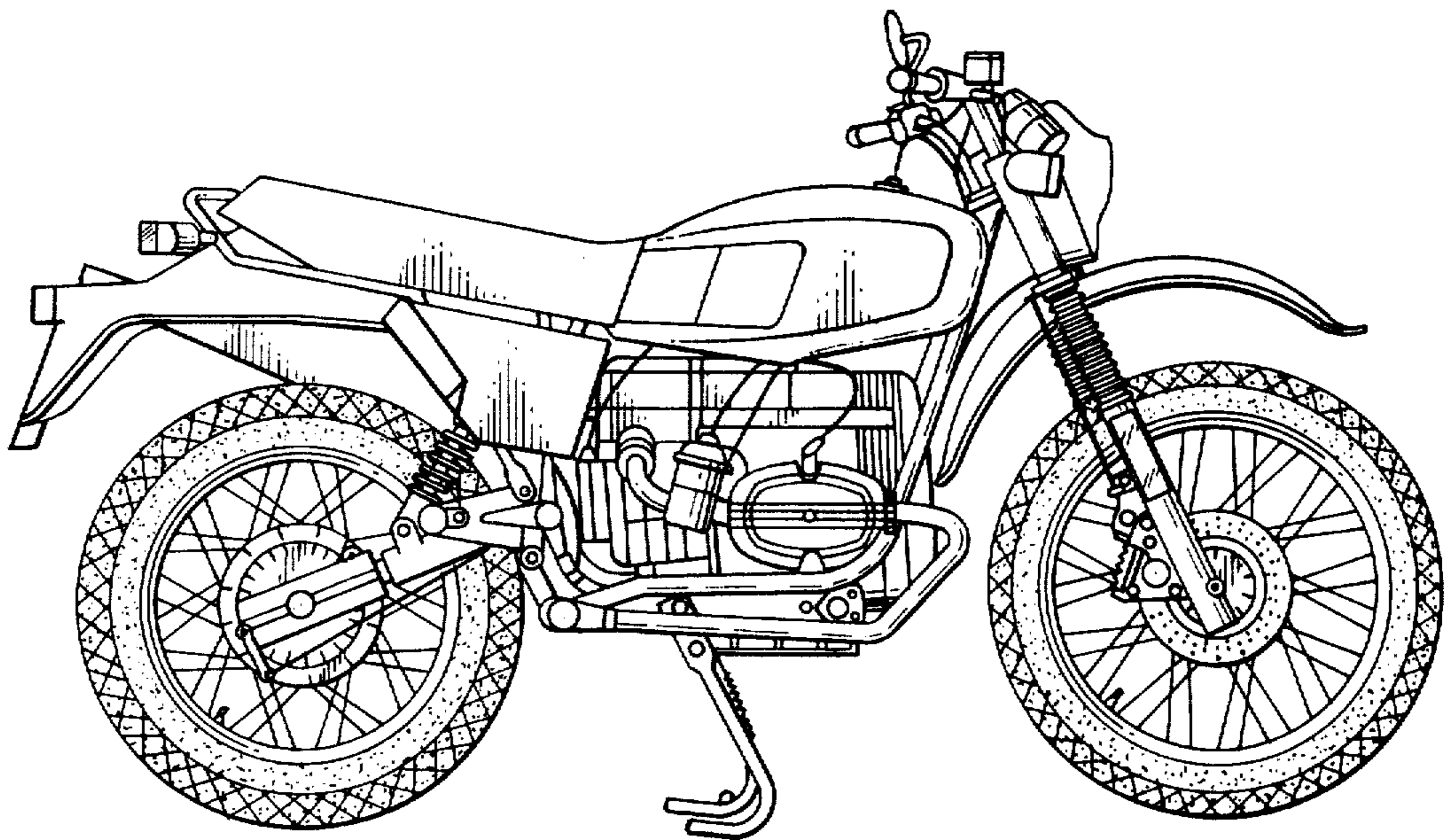

FIG. 3.

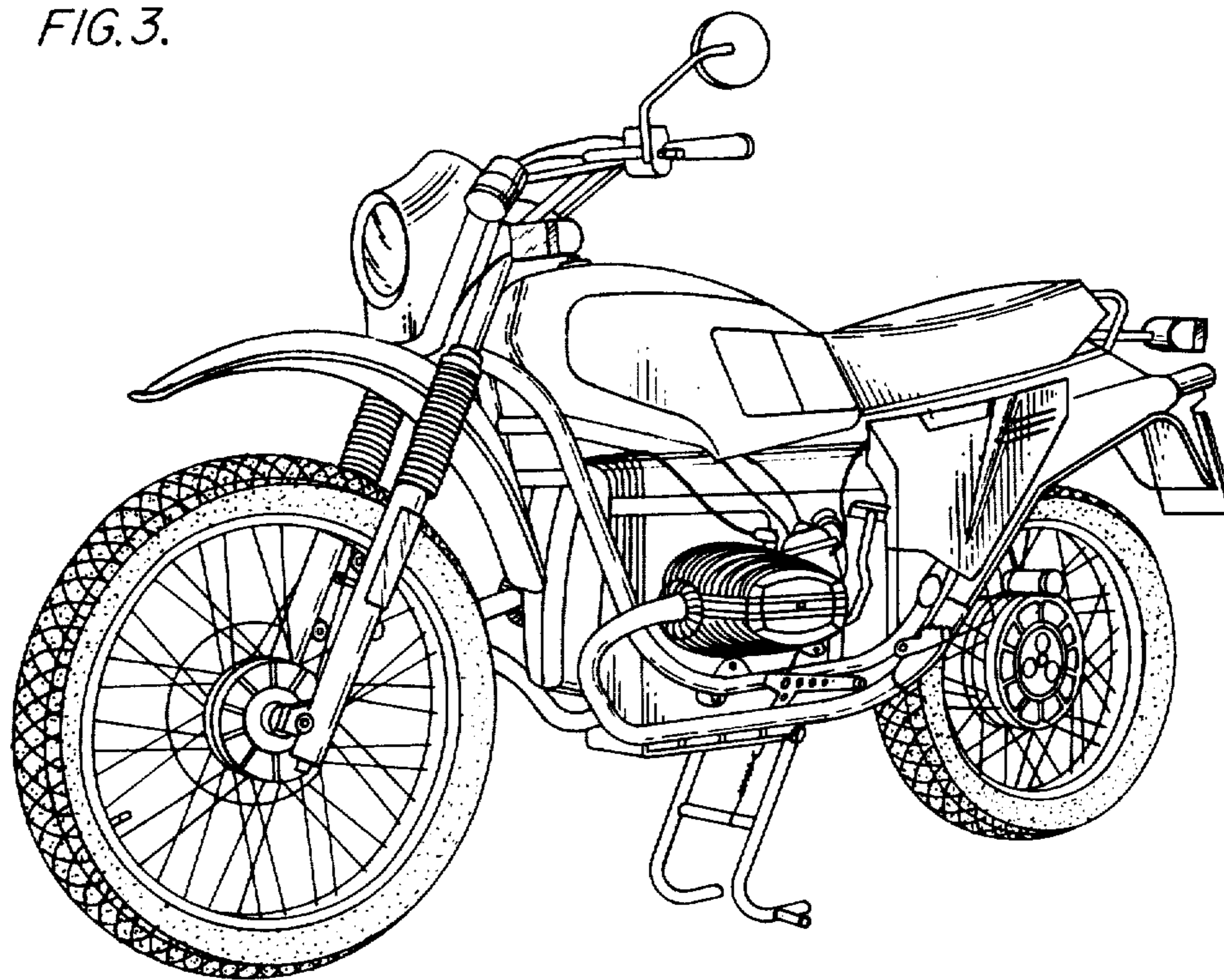

FIG. 4.

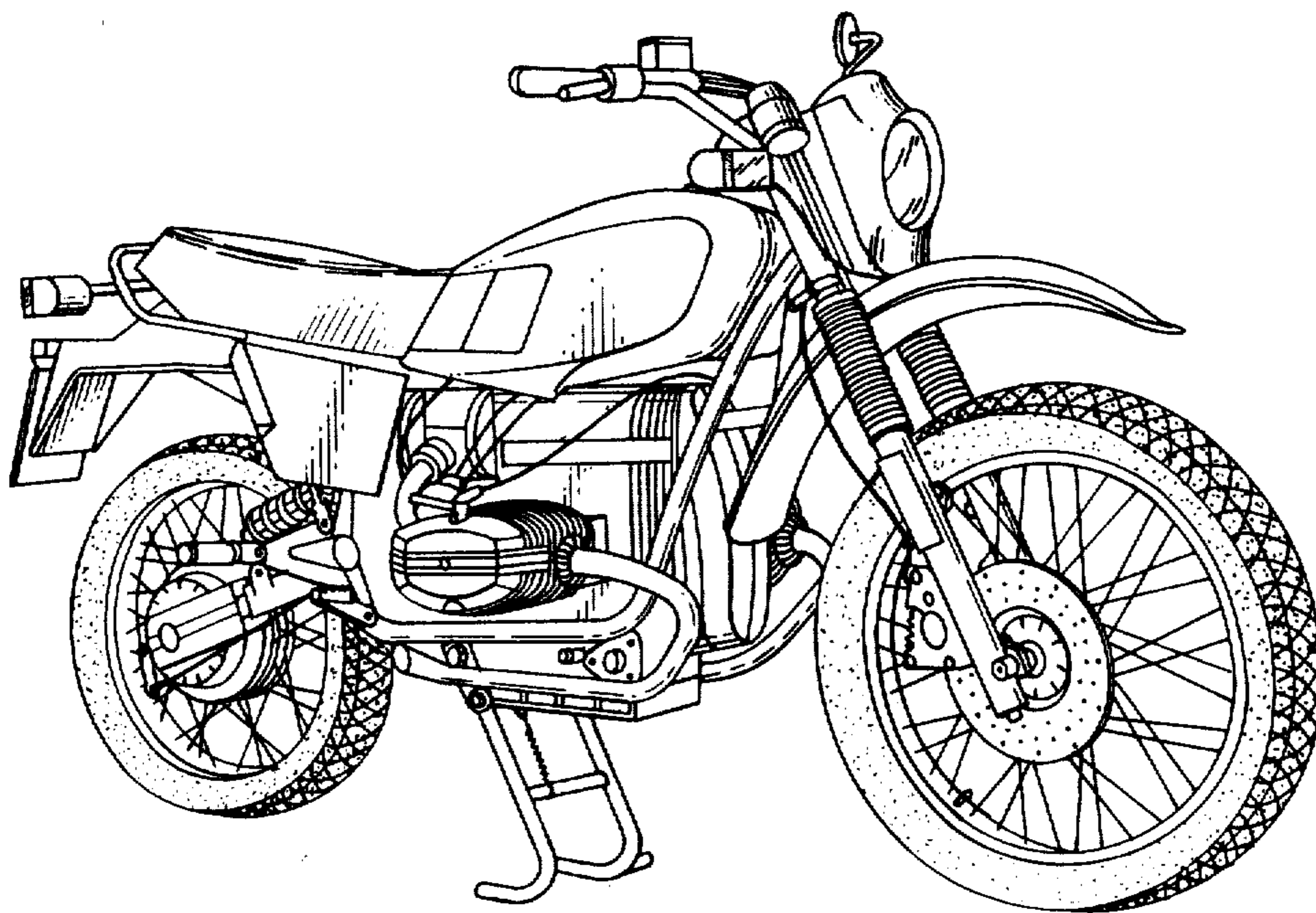

FIG. 5.

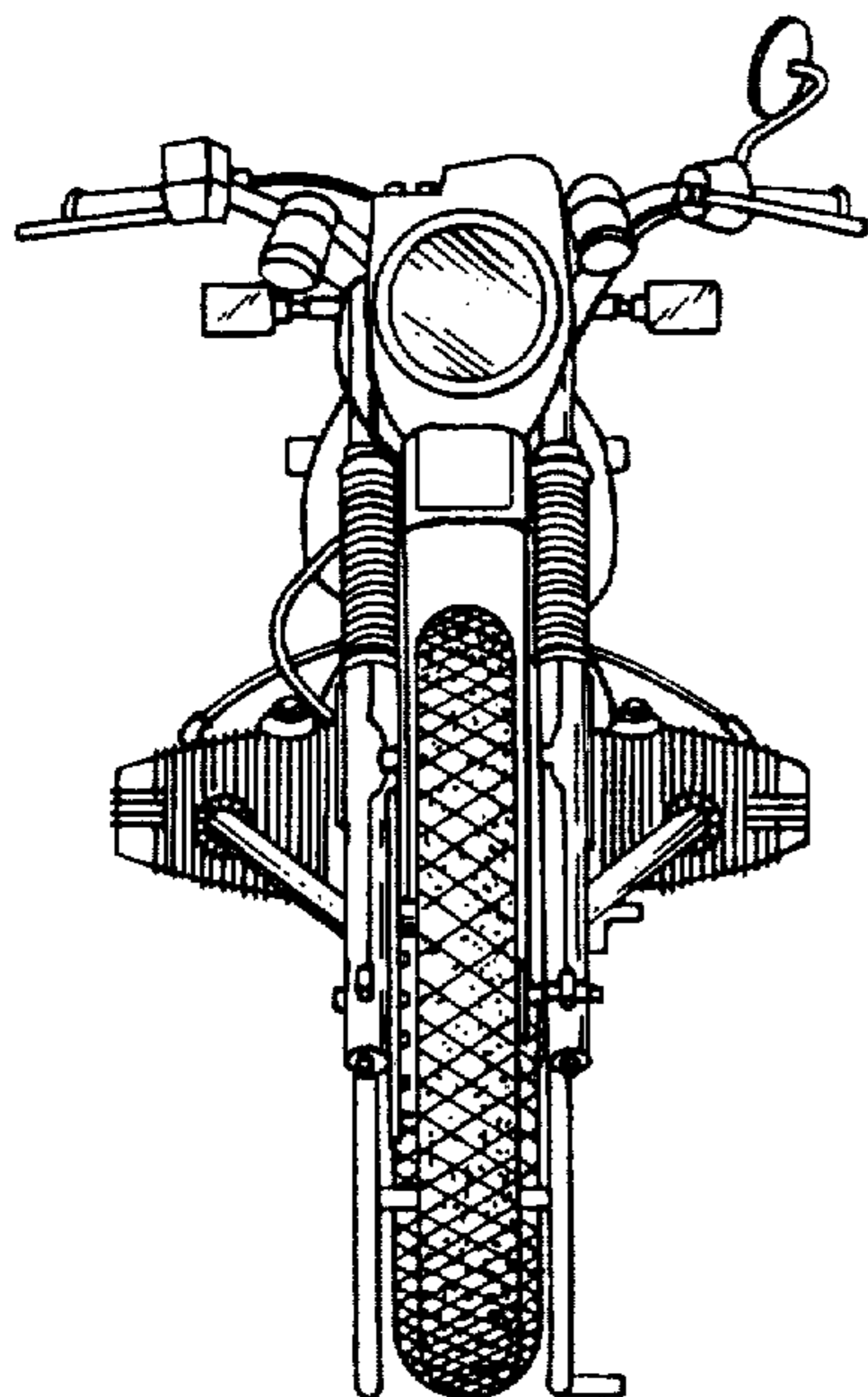

FIG. 6.

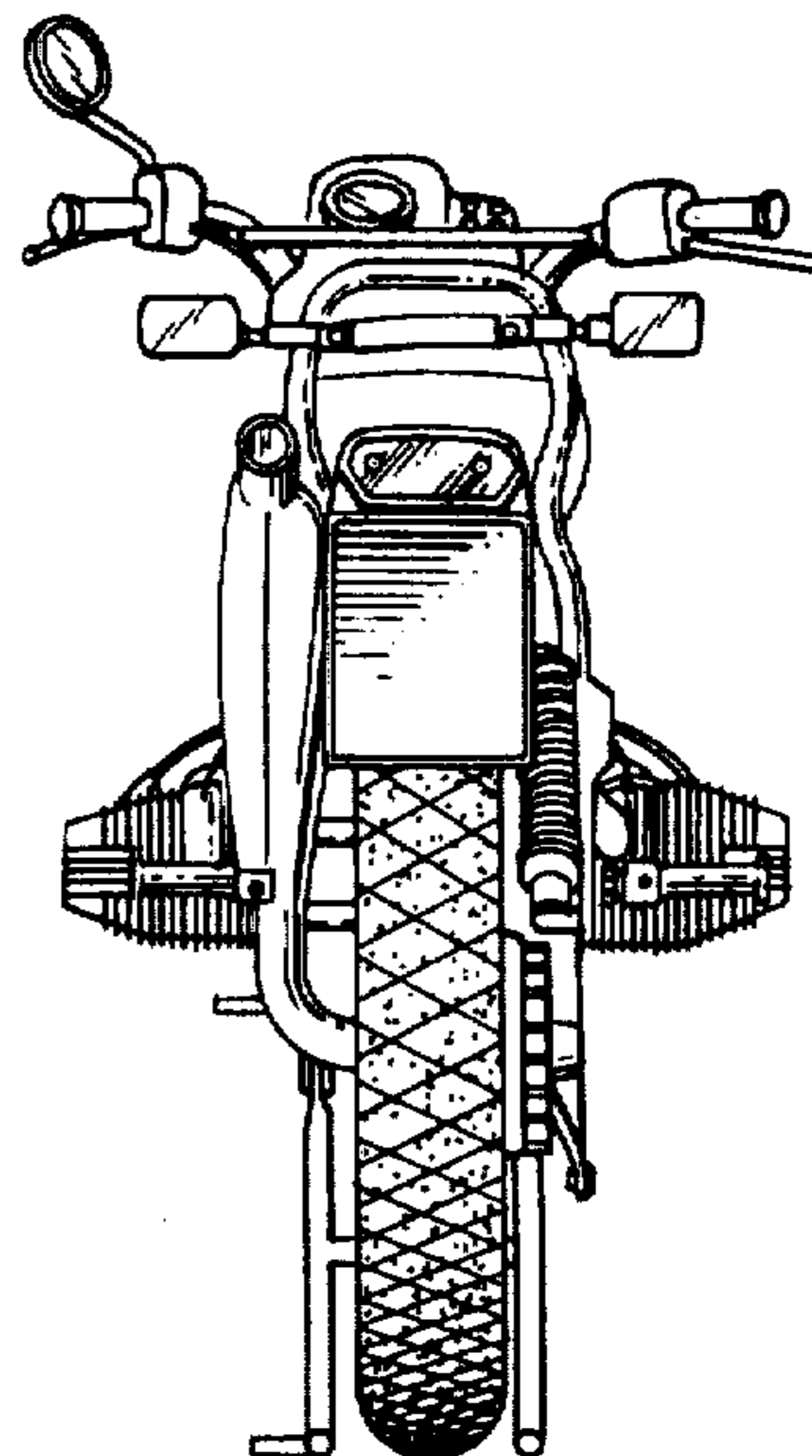

FIG. 7.

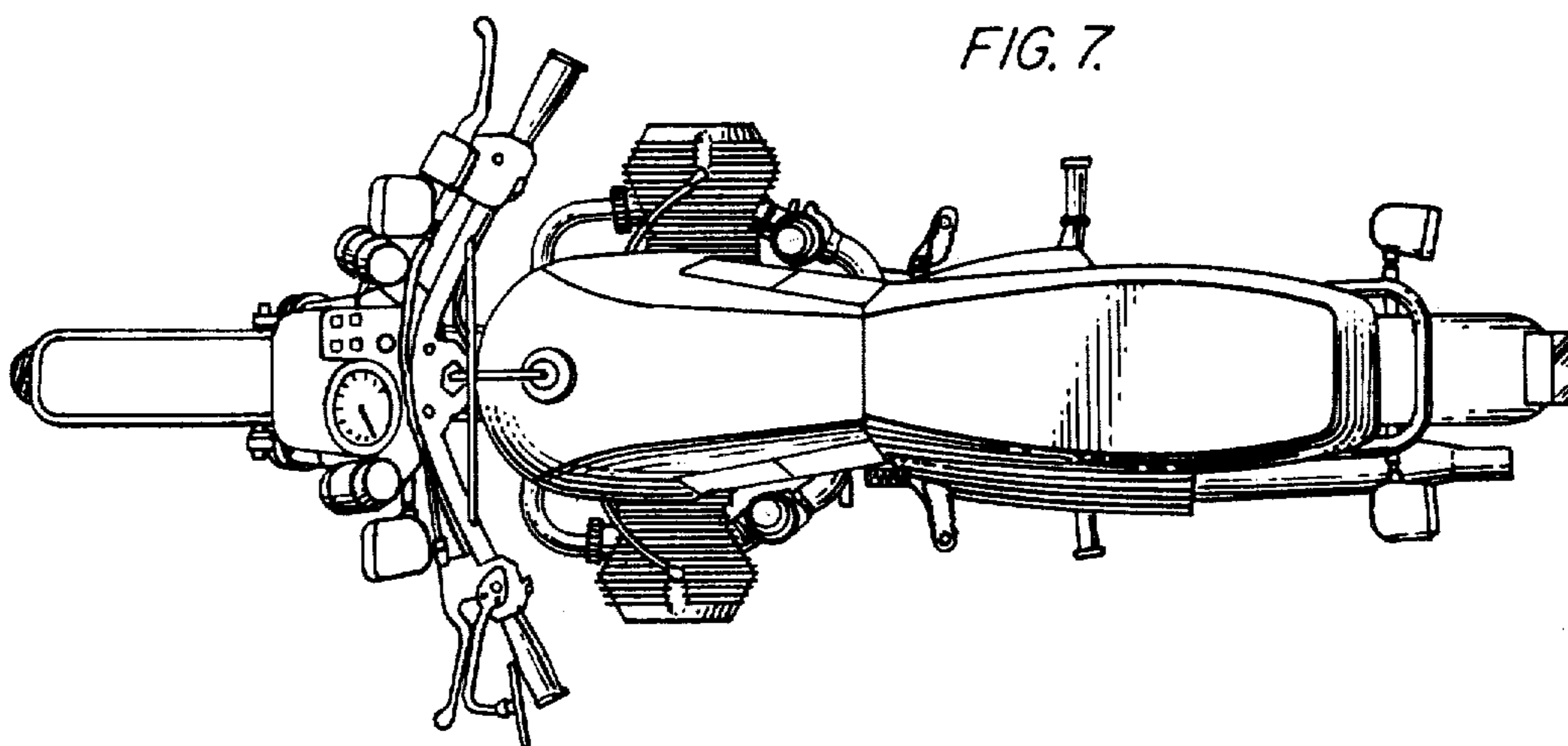

FIG. 8.

