

[54] CAN CARRIER

[75] Inventor: Horst F. W. Arfert, Midlothian, Va.

[73] Assignee: Reynolds Metals Company,
Richmond, Va.

[**] Term: 14 Years

[21] Appl. No.: 321,415

[22] Filed: Nov. 16, 1981

3,346,106	10/1967	Gooding	206/151
3,355,013	11/1967	Pupitch	206/150
3,446,346	5/1969	Burge	206/151
3,589,509	6/1971	Mascia	206/151
3,871,699	3/1975	Hatfield	206/150 X
4,120,396	10/1978	Mascia et al.	206/151

Primary Examiner—Robert C. Spangler
Attorney, Agent, or Firm—Alan T. McDonald

[57] CLAIM

The ornamental design for a can carrier, as shown and described.

Related U.S. Application Data

[62] Division of Ser. No. 130,745, Mar. 17, 1980.

[51] Int. Cl. D9—99

[52] U.S. Cl. D9/344

[58] Field of Search D9/345, 344, 416, 438;
206/150, 152, 151, 153, 65 C; 53/35; 294/87.2;
229/526 C

DESCRIPTION

FIG. 1 is a top elevational view of a can carrier embodying my new design;
FIG. 2 is a bottom elevational view;
FIG. 3 is a side elevational view;
FIG. 4 is a front elevational view;
FIG. 5 is a cross-sectional view, taken on line 5—5 of FIG. 1;
FIG. 6 is a top elevational view of a second embodiment of my new design;
FIG. 7 is a bottom elevational view;
FIG. 8 is a side elevational view;
FIG. 9 is a front elevational view; and
FIG. 10 is a cross-sectional view, taken on line 10—10 of FIG. 6.

[56] References Cited

U.S. PATENT DOCUMENTS

D. 228,344	9/1973	Markert	D9/438
3,242,631	3/1966	Whiteford	53/35
3,250,564	5/1966	Stern et al.	294/87.2
3,307,692	3/1967	Chidsey, Jr.	206/150
3,317,234	5/1967	Burford	294/87.2

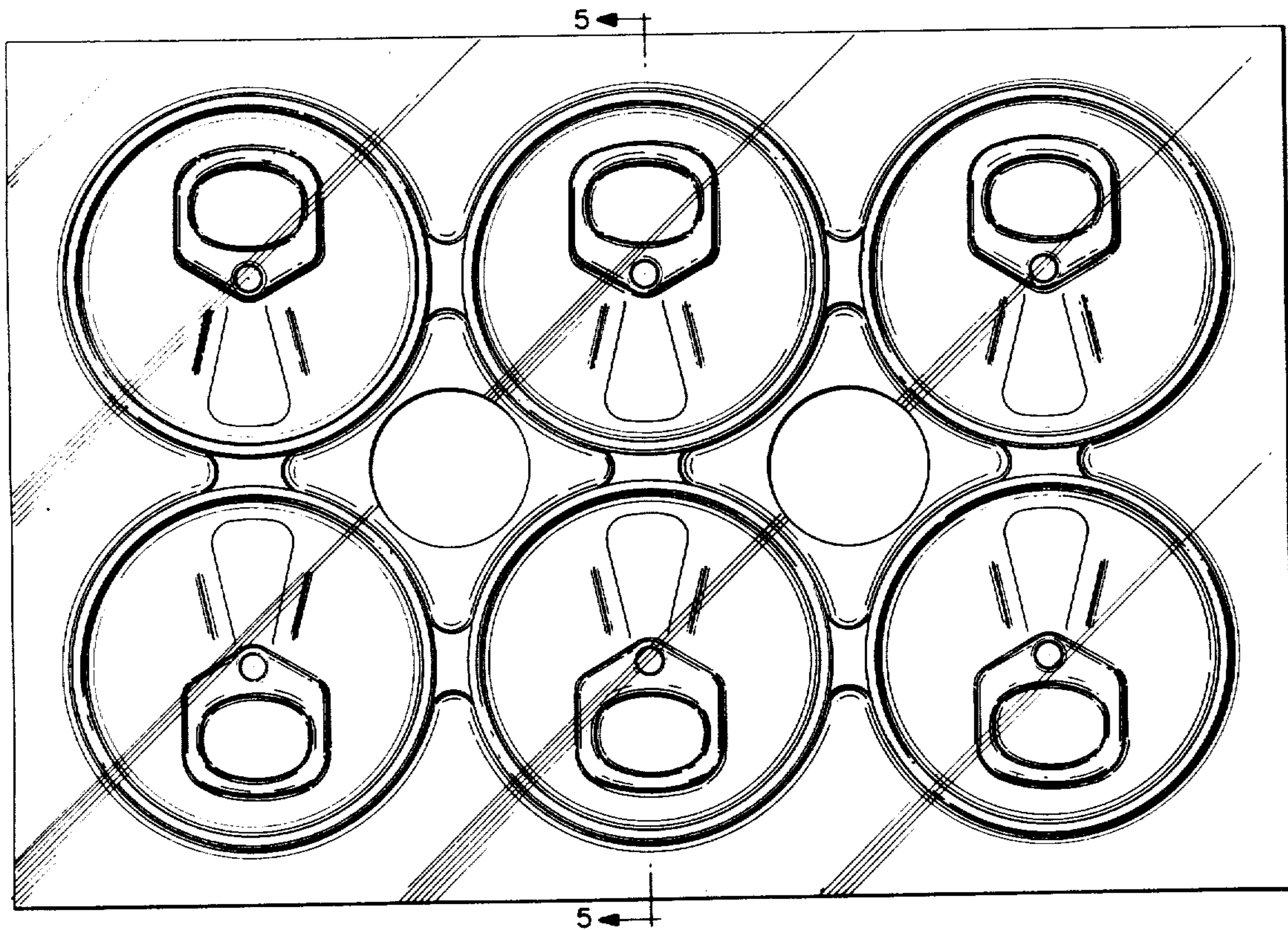

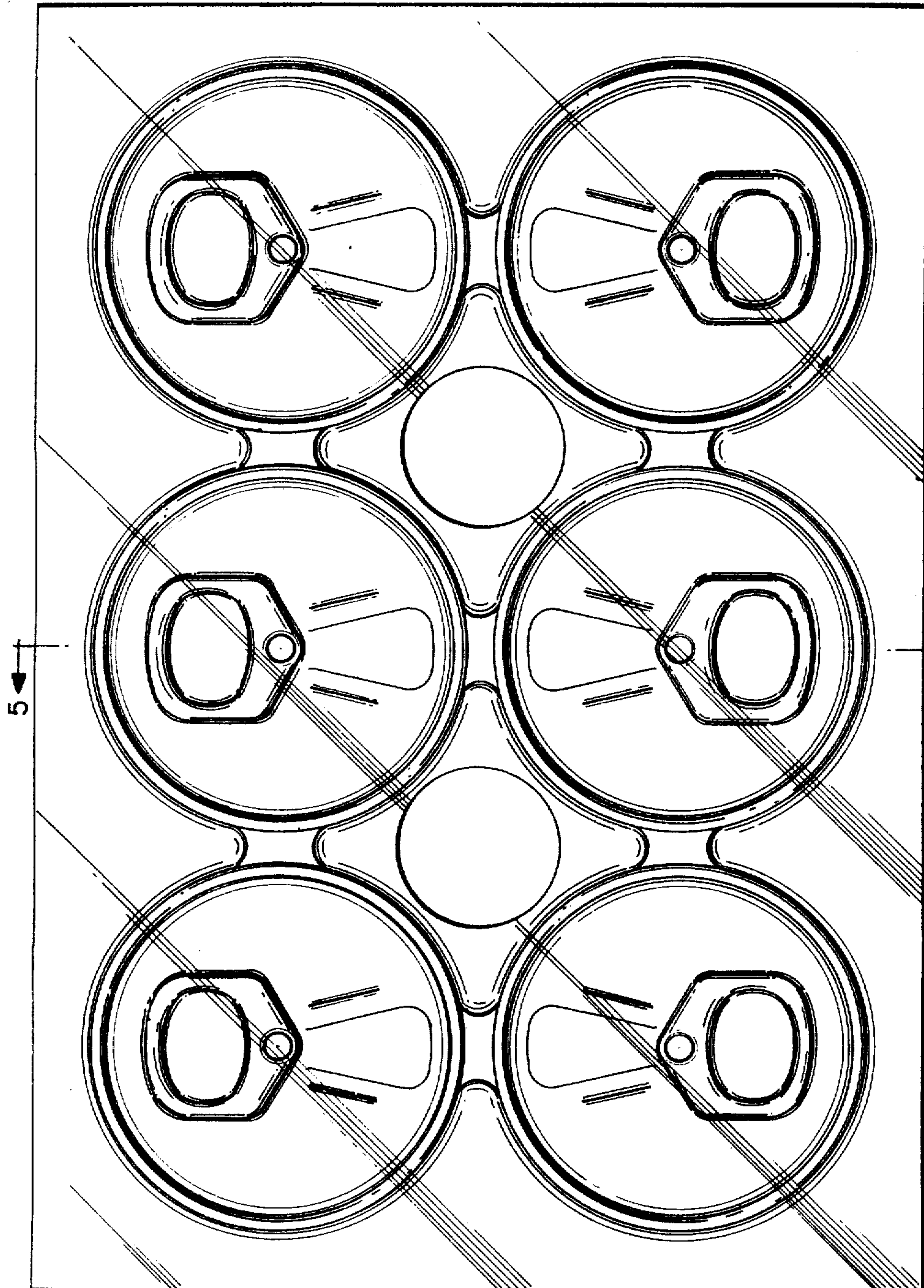
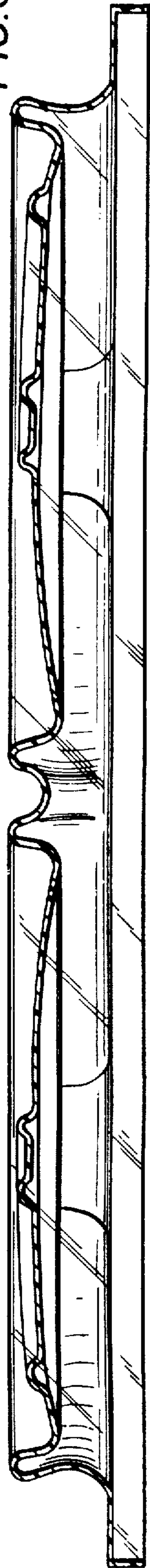

FIG. 1

FIG. 5



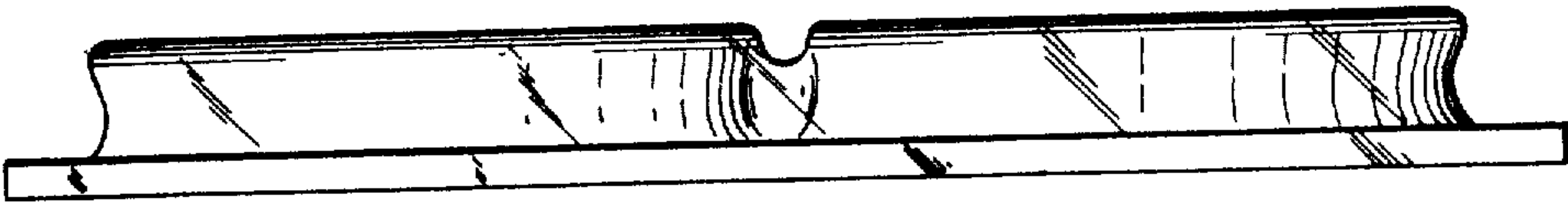

FIG. 3

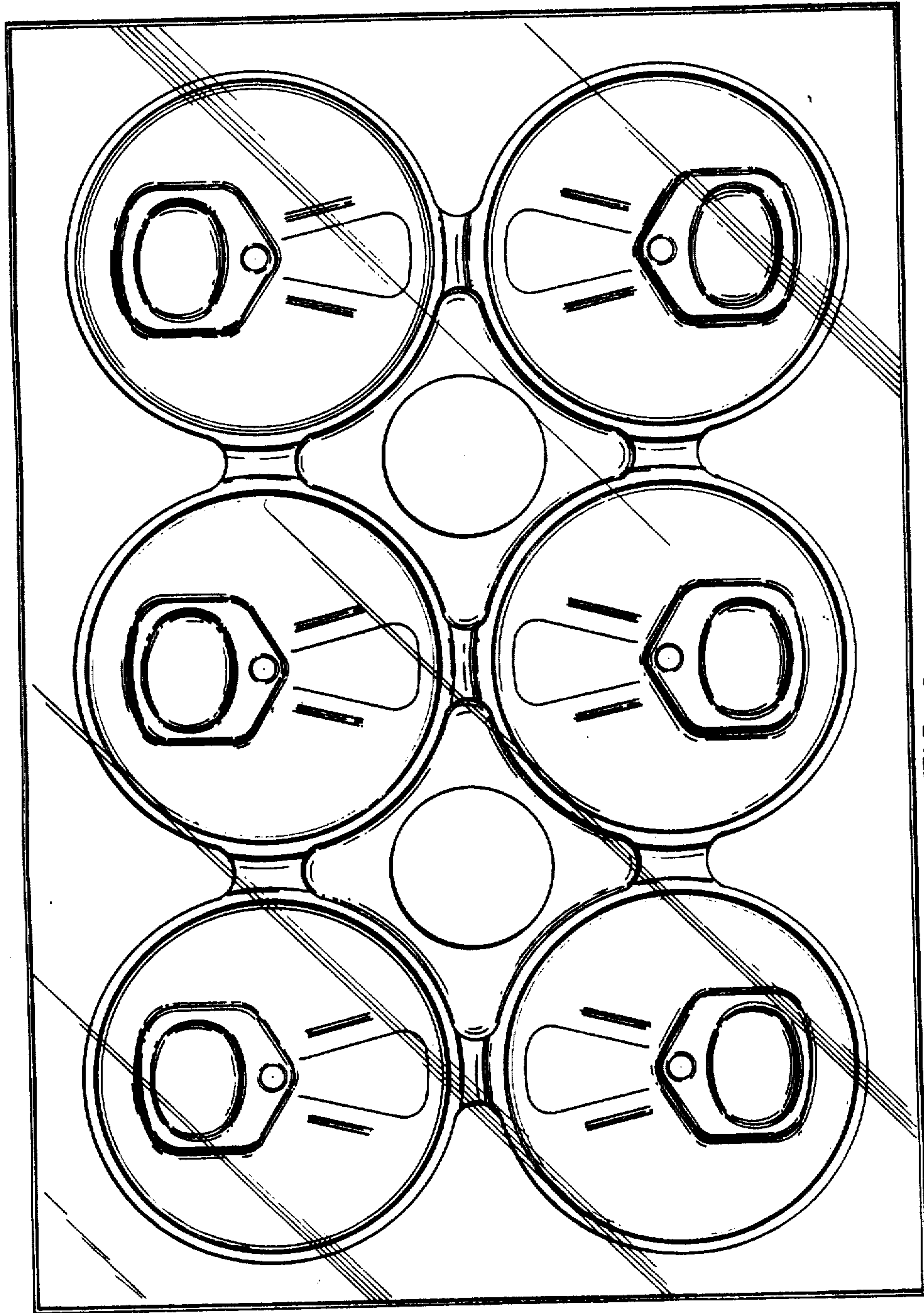

FIG. 2



FIG. 4

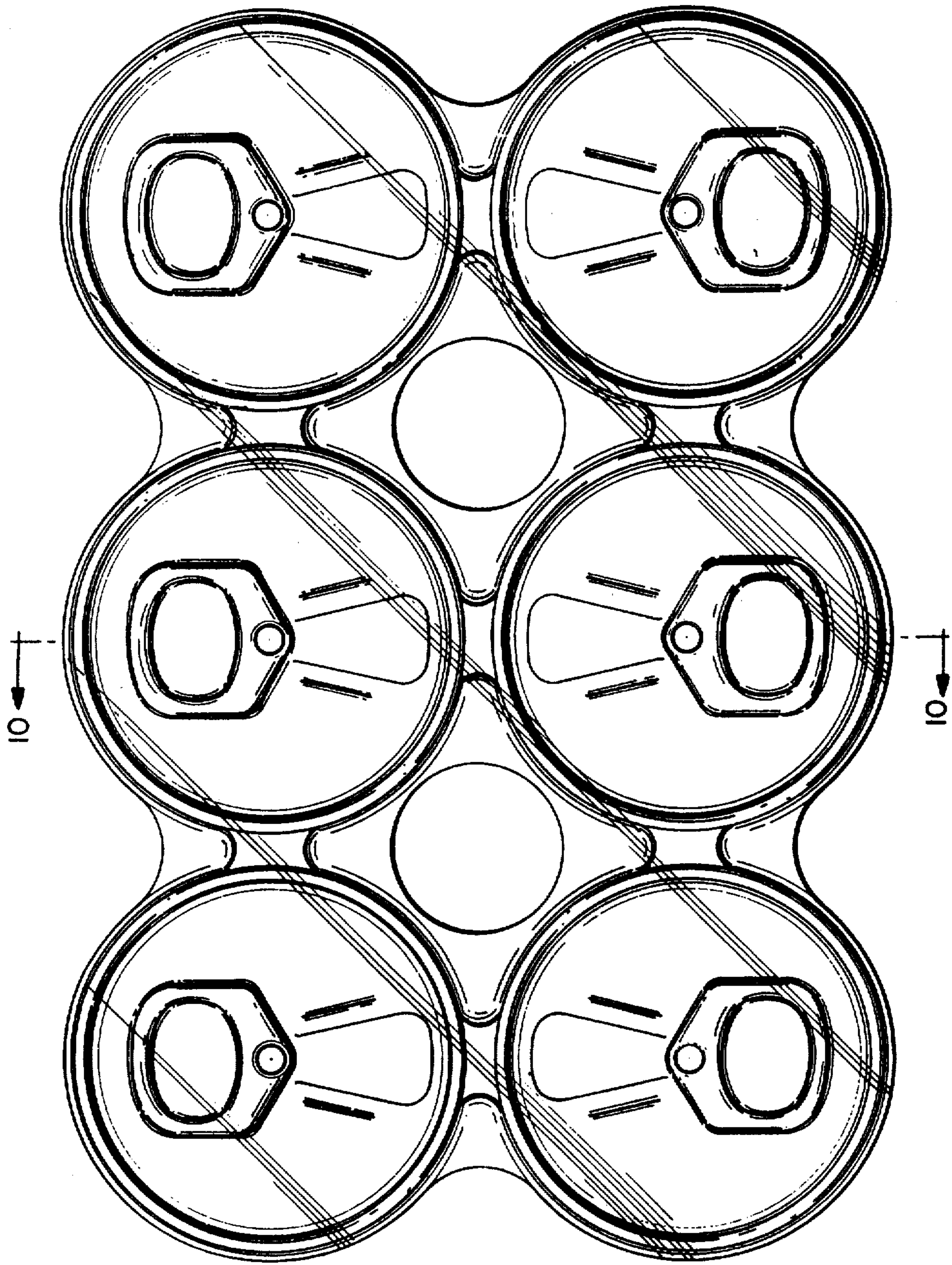

FIG. 6

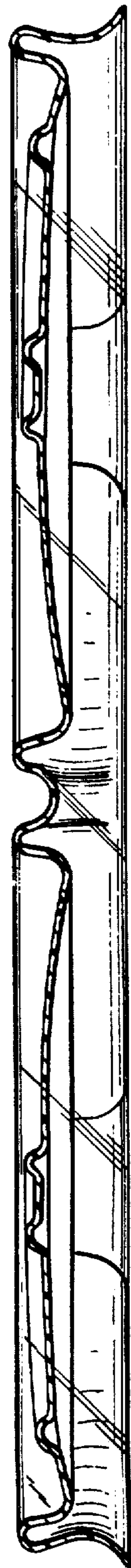

FIG. 10



FIG. 8

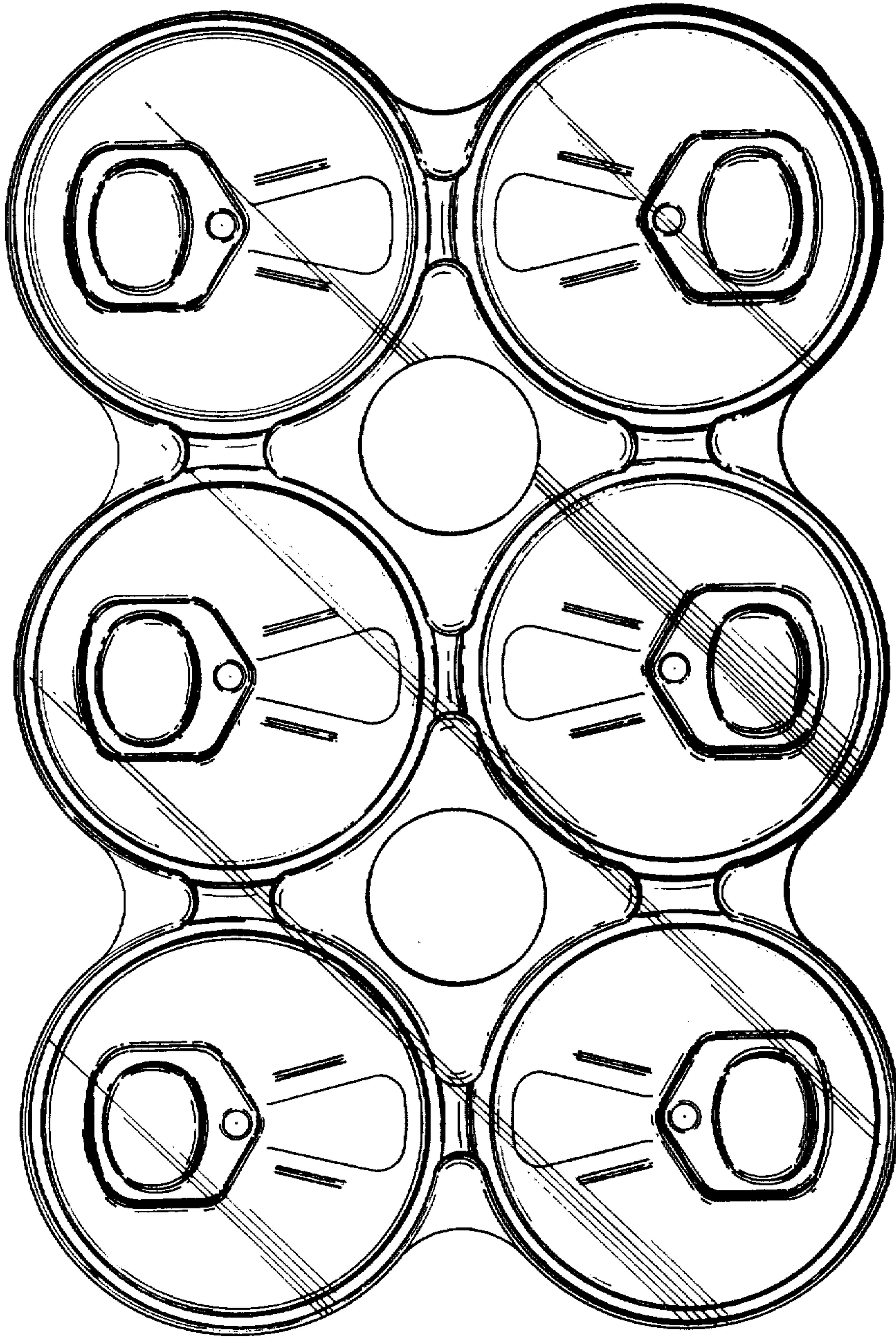

FIG. 7



FIG. 9