

[54] EXTRUSION MOULDING APPARATUS

[75] Inventor: Robert Kay, Poynton, England

[73] Assignee: Harbutt's Plasticine Limited, Bathampton, England

[**] Term: 14 Years

[21] Appl. No.: 83,006

[22] Filed: Oct. 9, 1979

[30] Foreign Application Priority Data

Jun. 1, 1979 [GB] United Kingdom 79990146

[51] Int. Cl. D15-99

[52] U.S. Cl. D15/135; D8/71

[58] Field of Search 264/328.1-328.19; D8/71; D15/122, 135, 136, 137

[56] References Cited

U.S. PATENT DOCUMENTS

- D. 198,101 4/1964 Looser D15/135
- D. 234,470 3/1975 Haygeman D15/135
- 2,433,654 12/1947 Dinzl D15/135 X

3,137,038 6/1964 Maynard 264/328.4 X

Primary Examiner—A. Hugo Word
Attorney, Agent, or Firm—Fred Philpitt

[57] CLAIM

The ornamental design for an extrusion moulding apparatus, as shown.

DESCRIPTION

FIG. 1 is a perspective view from above and one side of the extrusion moulding apparatus,
 FIG. 2 is an exploded side elevation of the extrusion moulding apparatus,
 FIG. 3 is a top plan view of the extrusion moulding apparatus,
 FIG. 4 is a side elevation of the extrusion moulding apparatus,
 FIG. 5 is an end elevation of the extrusion moulding apparatus,
 FIG. 6 is an underneath plan view of the extrusion moulding apparatus,
 FIG. 7 is a sectional plan view on line X—X of FIG. 2 of the extrusion moulding apparatus.

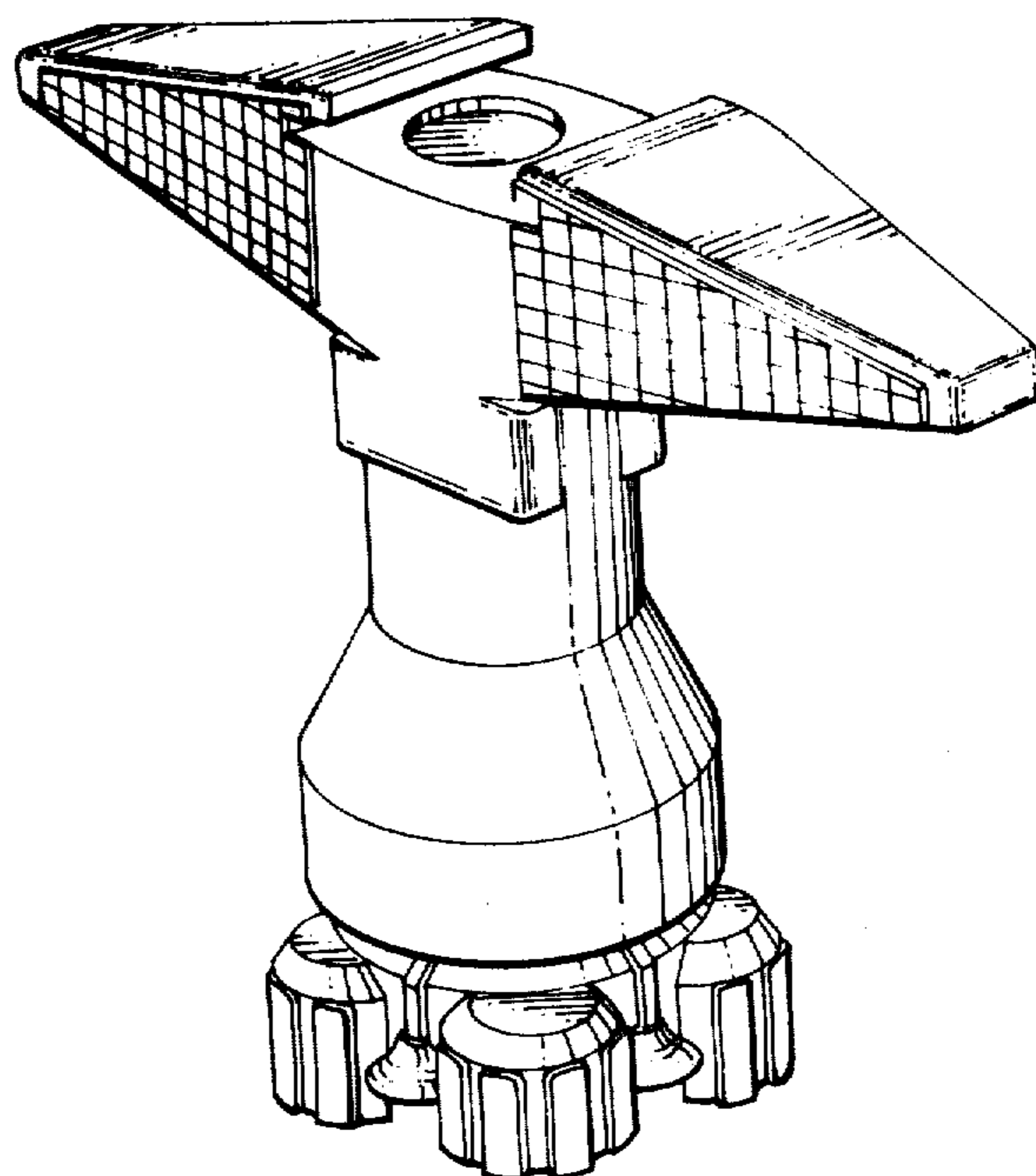

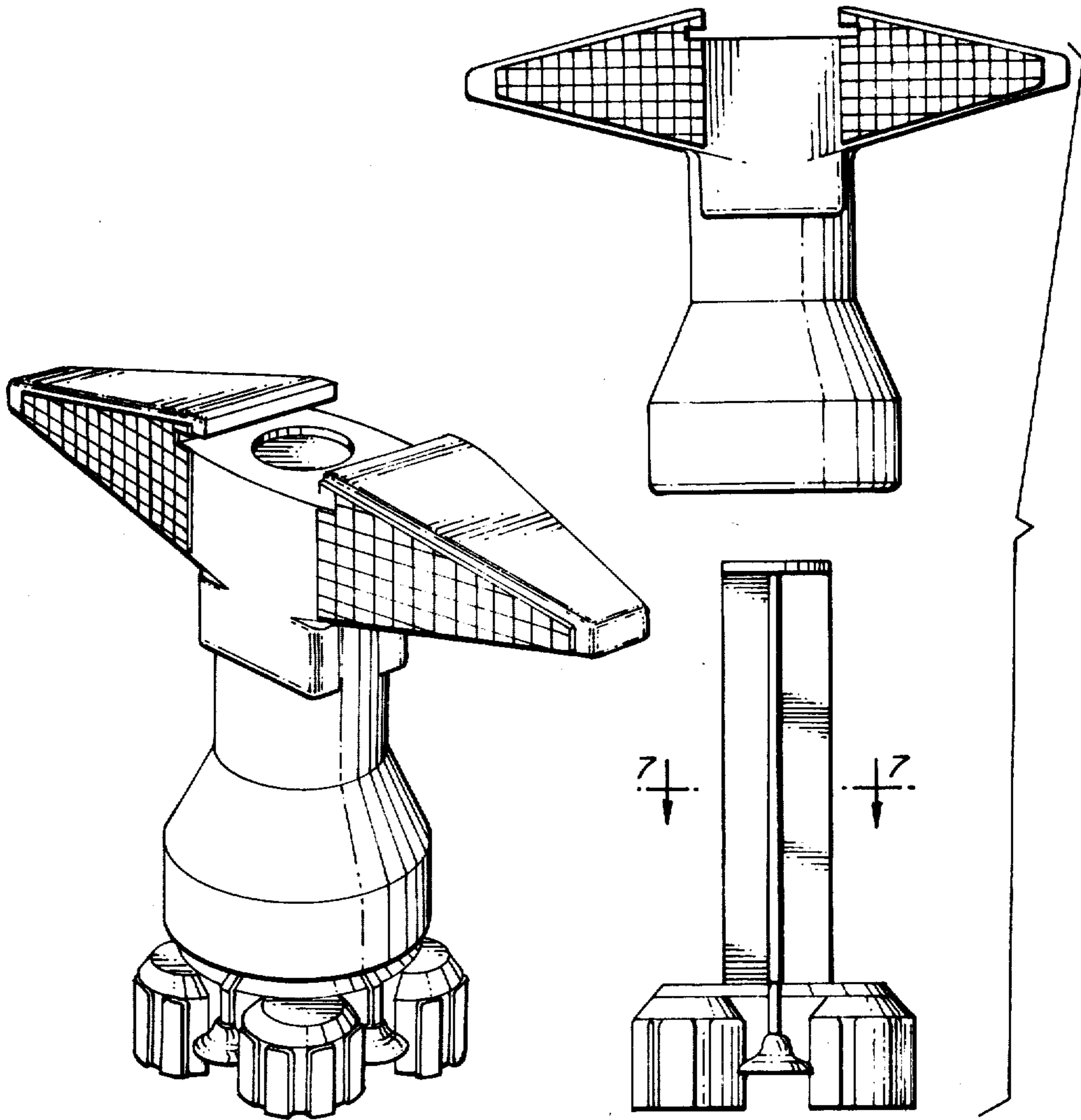

FIG. 1

FIG. 2

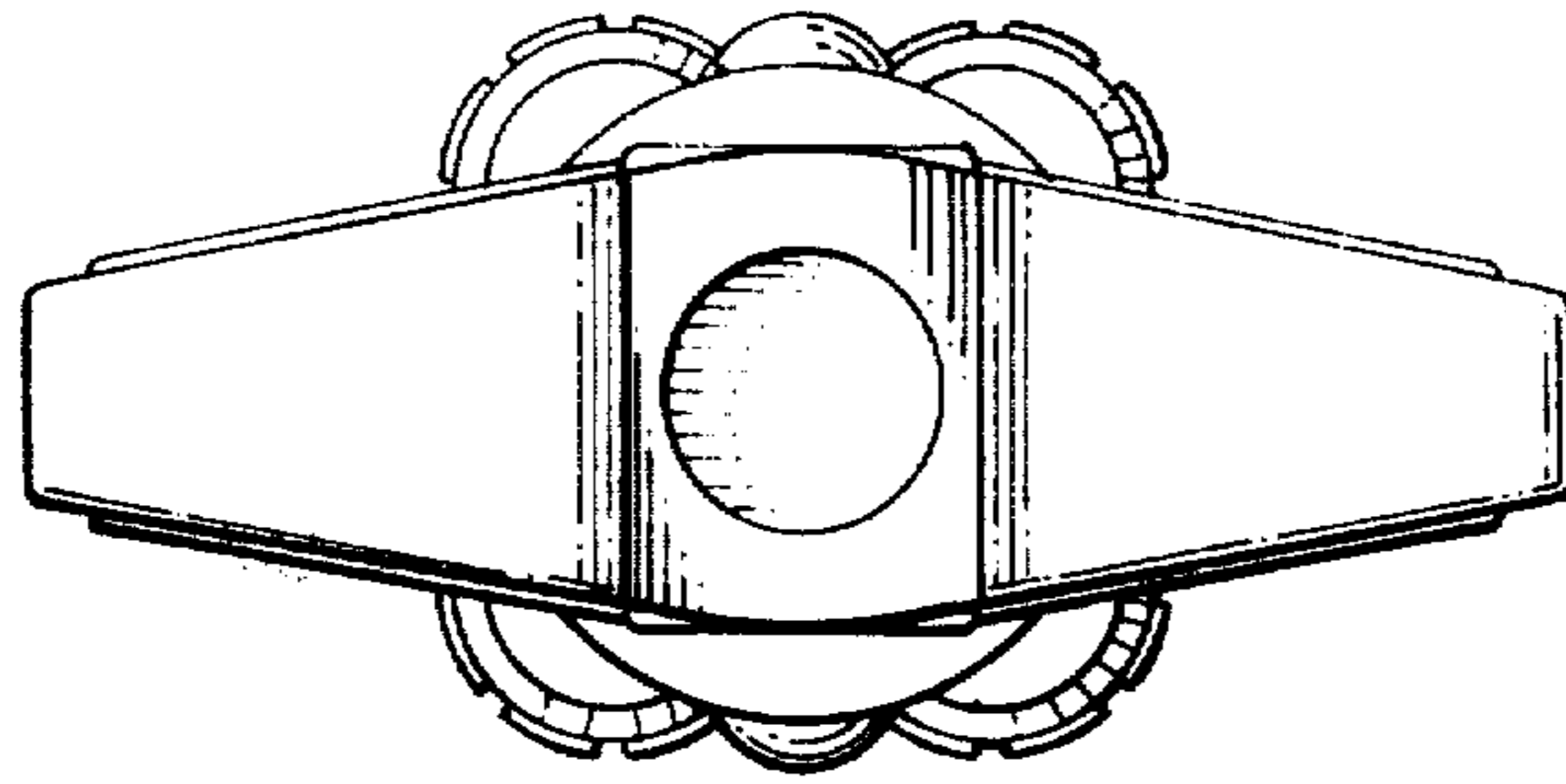

FIG. 3

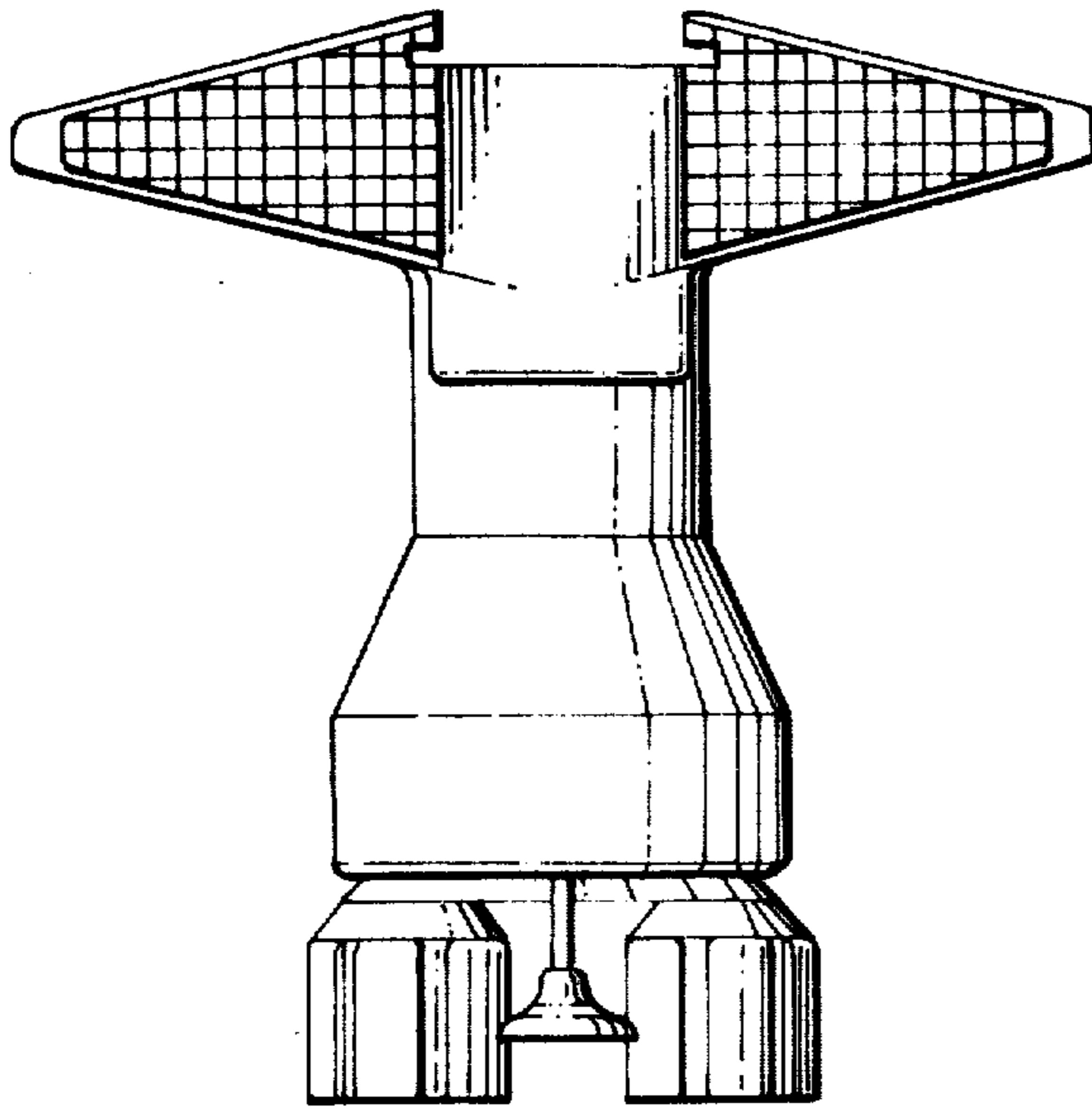

FIG. 4

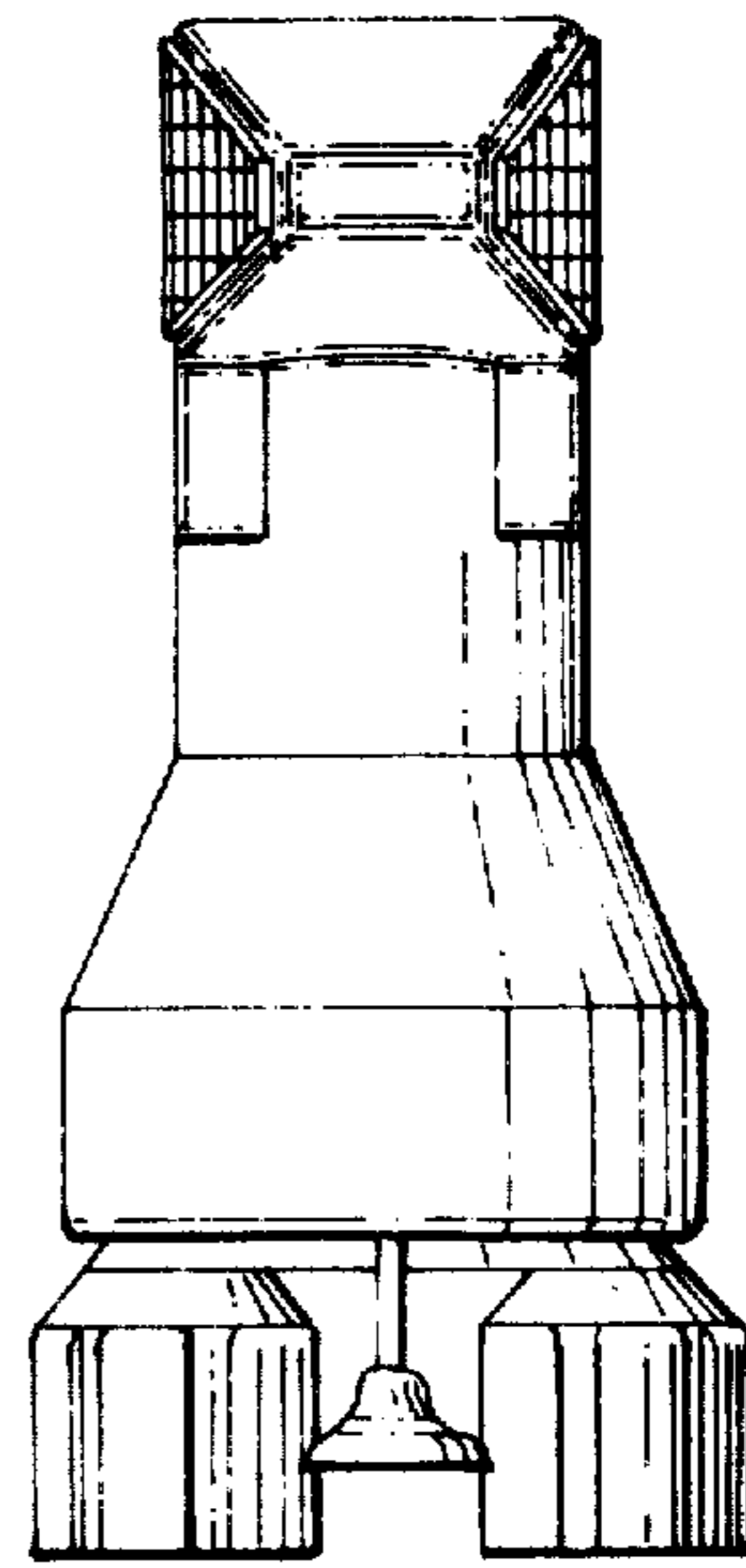

FIG. 5

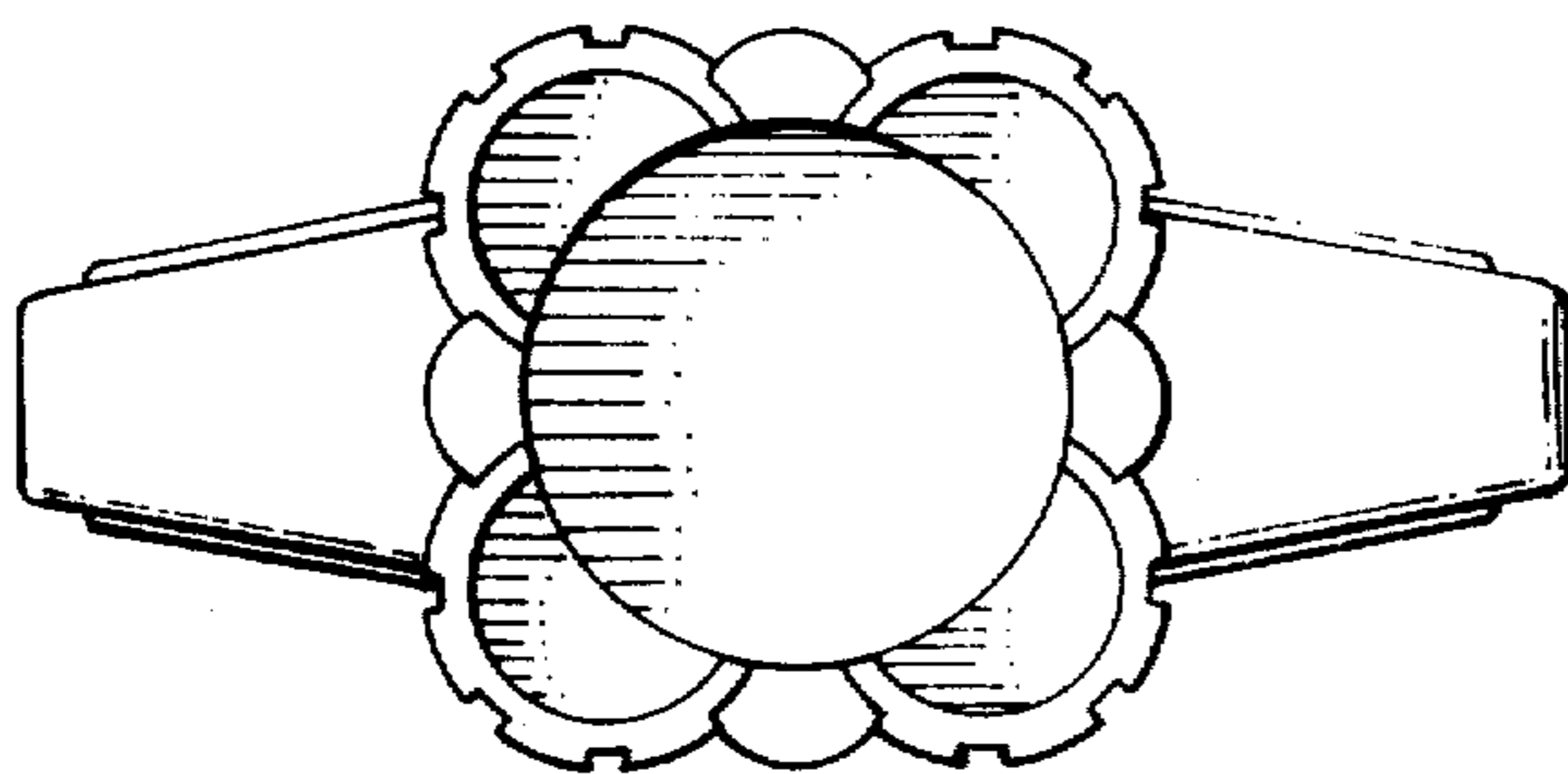

FIG. 6

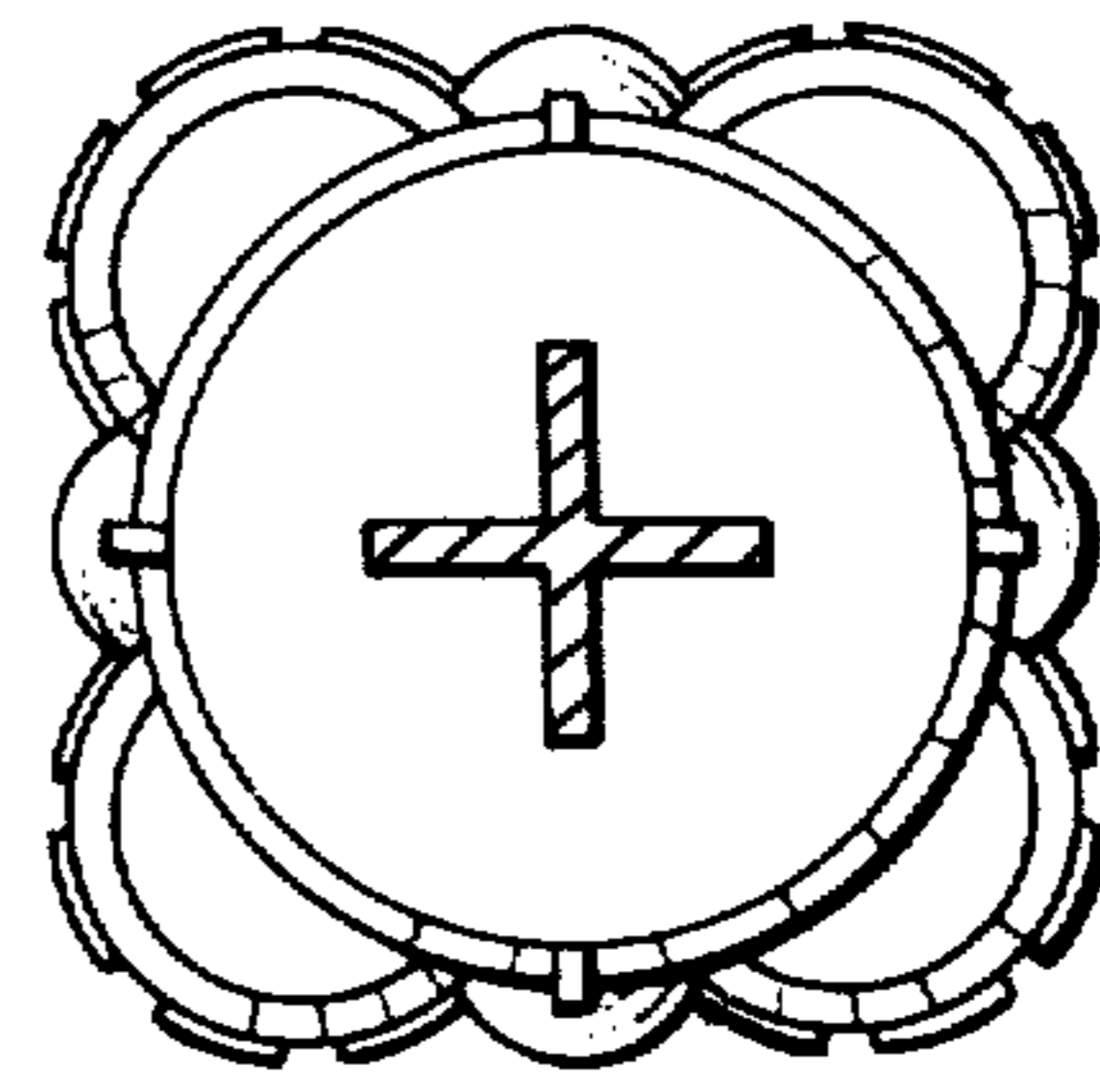

FIG. 7