

[54] MOTORCYCLE

[75] Inventors: Tetsuro Kataoka, Kawagoe; Yutaka Kawasaki, Tokyo, both of Japan

[73] Assignee: Honda Giken Kogyo Kabushiki Kaisha, Tokyo, Japan

[**] Term: 14 Years

[21] Appl. No.: 195,061

[22] Filed: Oct. 7, 1980

[30] Foreign Application Priority Data

Apr. 15, 1980 [JP] Japan 55-14884

[51] Int. Cl. D12-11

[52] U.S. Cl. D12/110

[58] Field of Search D12/110; 180/219

[56] References Cited

PUBLICATIONS

Moto Revue, 11/29/79, p. 65, Honda, center left side of page.

Cycle World, 6/79, p. 36, Suzuki RM125N, bottom of page.

Cycle World, 6/79, p. 37, Yamaha YZ125F & Kawasaki KX125.

Cycle World, 7/79, p. 29, Maico 450 Magnum.

Primary Examiner—James M. Gandy
Attorney, Agent, or Firm—Armstrong, Nikaido, Marmelstein & Kubovcik

[57] CLAIM

The ornamental design for a motorcycle, as shown and described.

DESCRIPTION

FIG. 1 is a left side elevational view of a motorcycle, showing our new design;

FIG. 2 is a right side elevational view thereof;

FIG. 3 is a front elevational view thereof;

FIG. 4 is a rear elevational view thereof;

FIG. 5 is a top plan view thereof;

FIG. 6 is a bottom plan view thereof; and

FIG. 7 is a perspective view thereof.

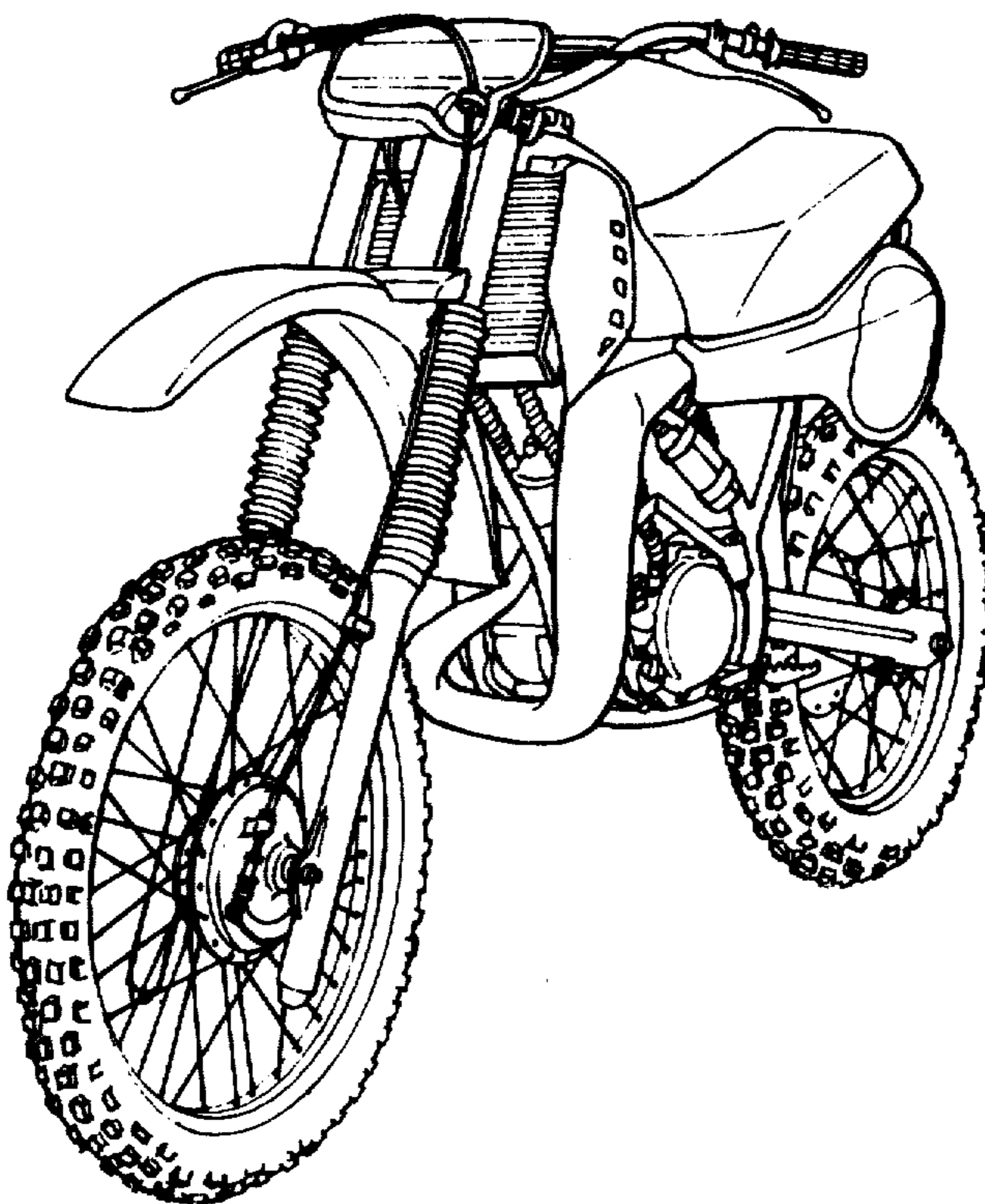

FIG. 1

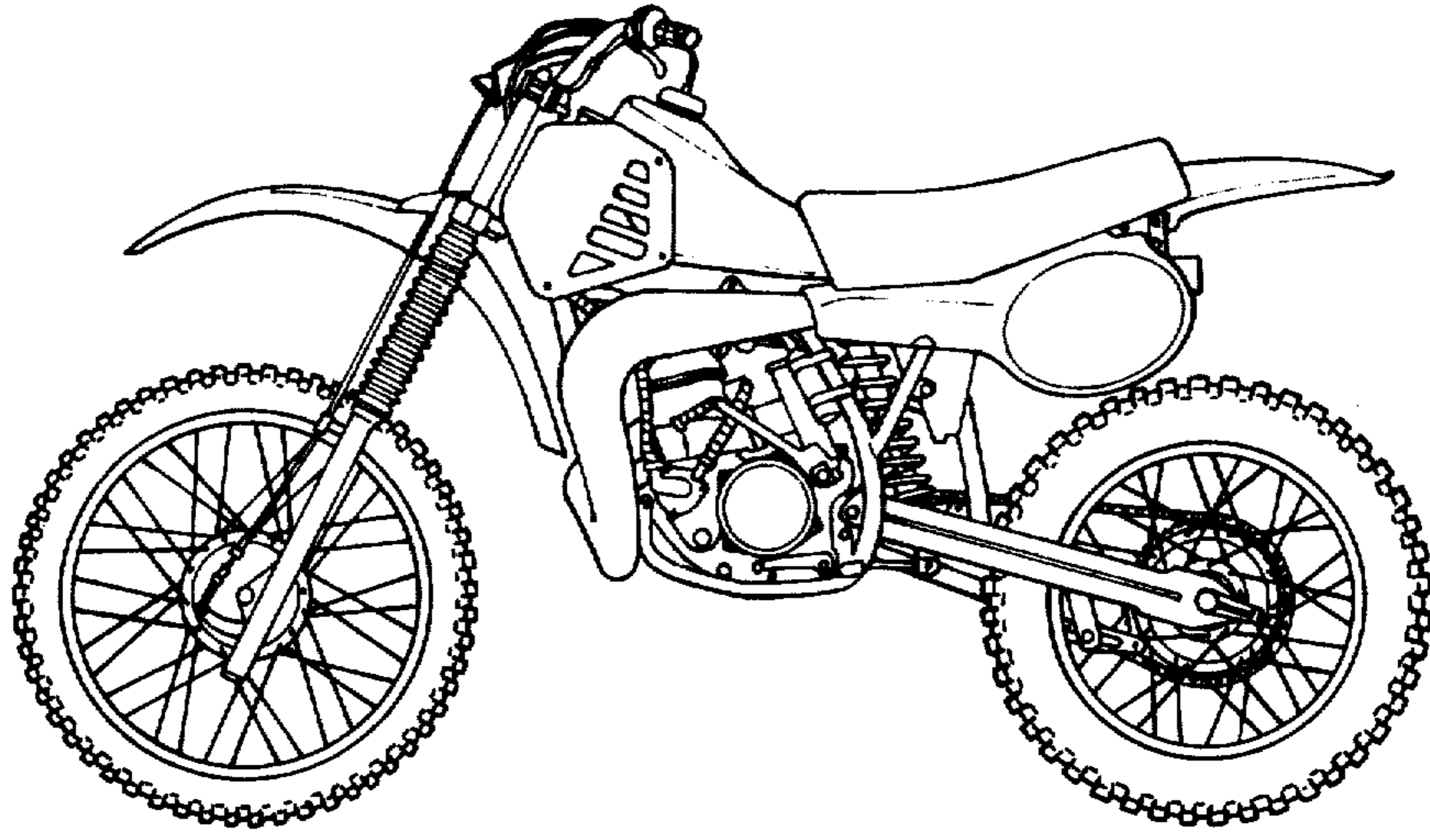

FIG. 2

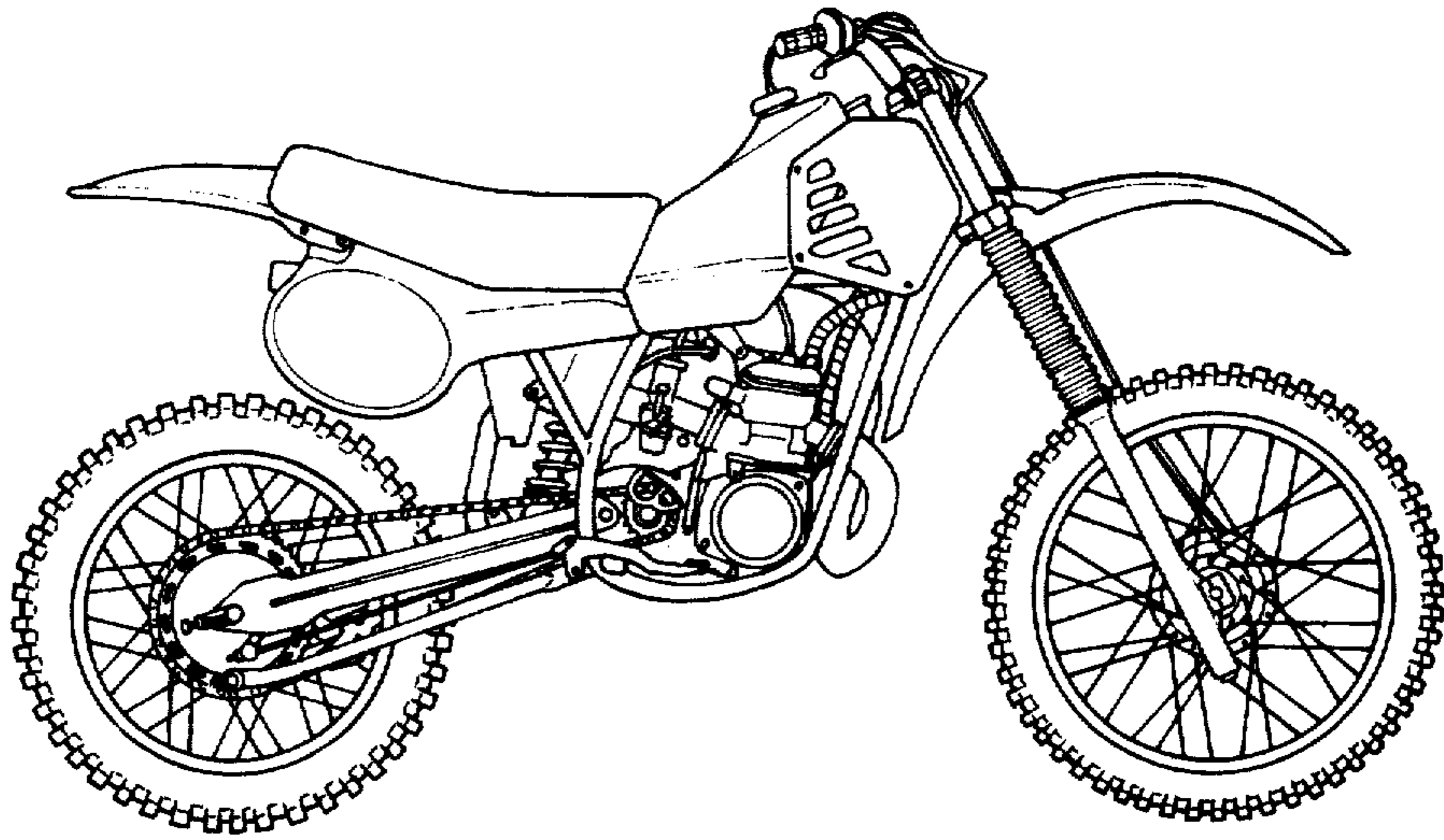

FIG. 3

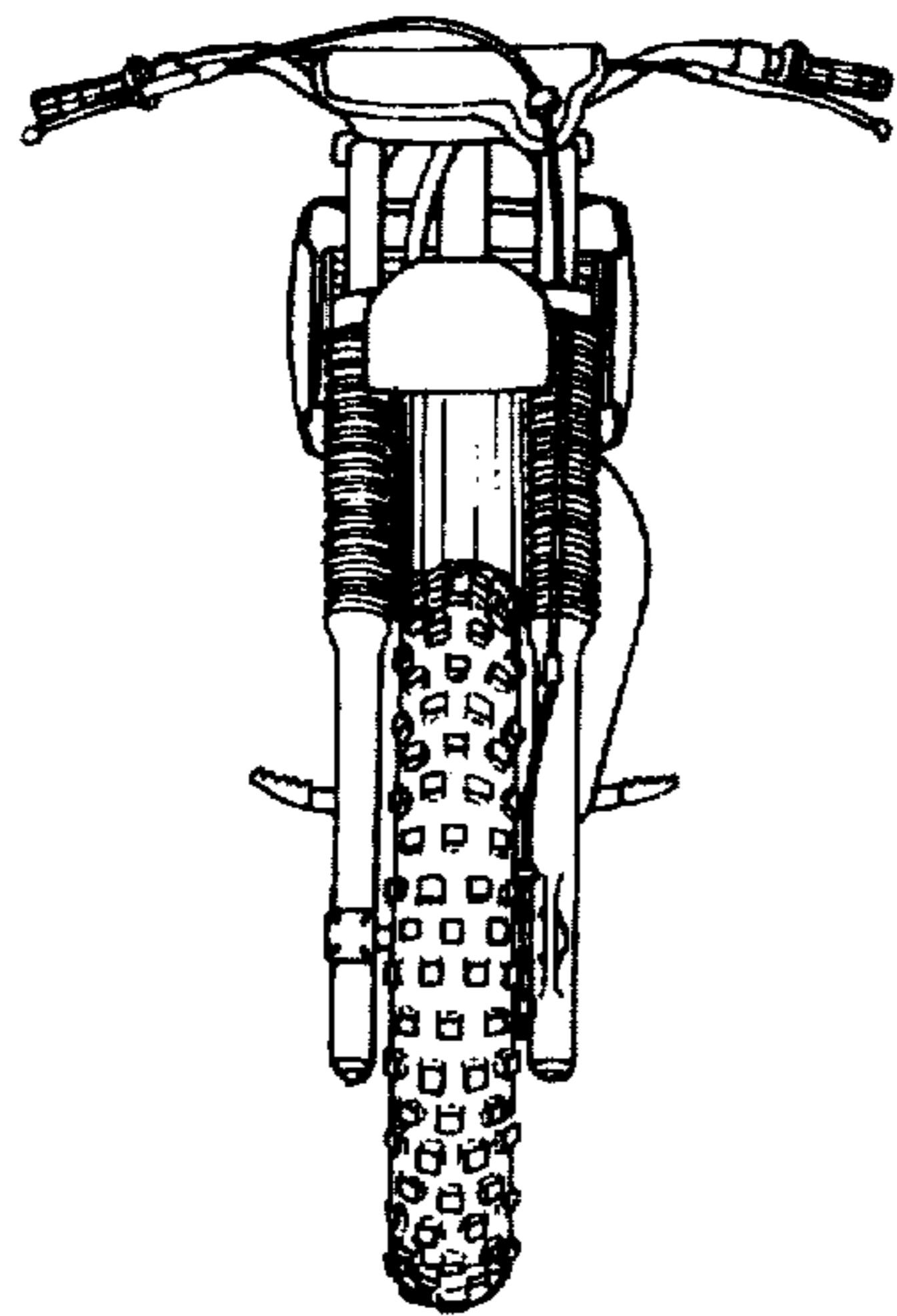

FIG. 4

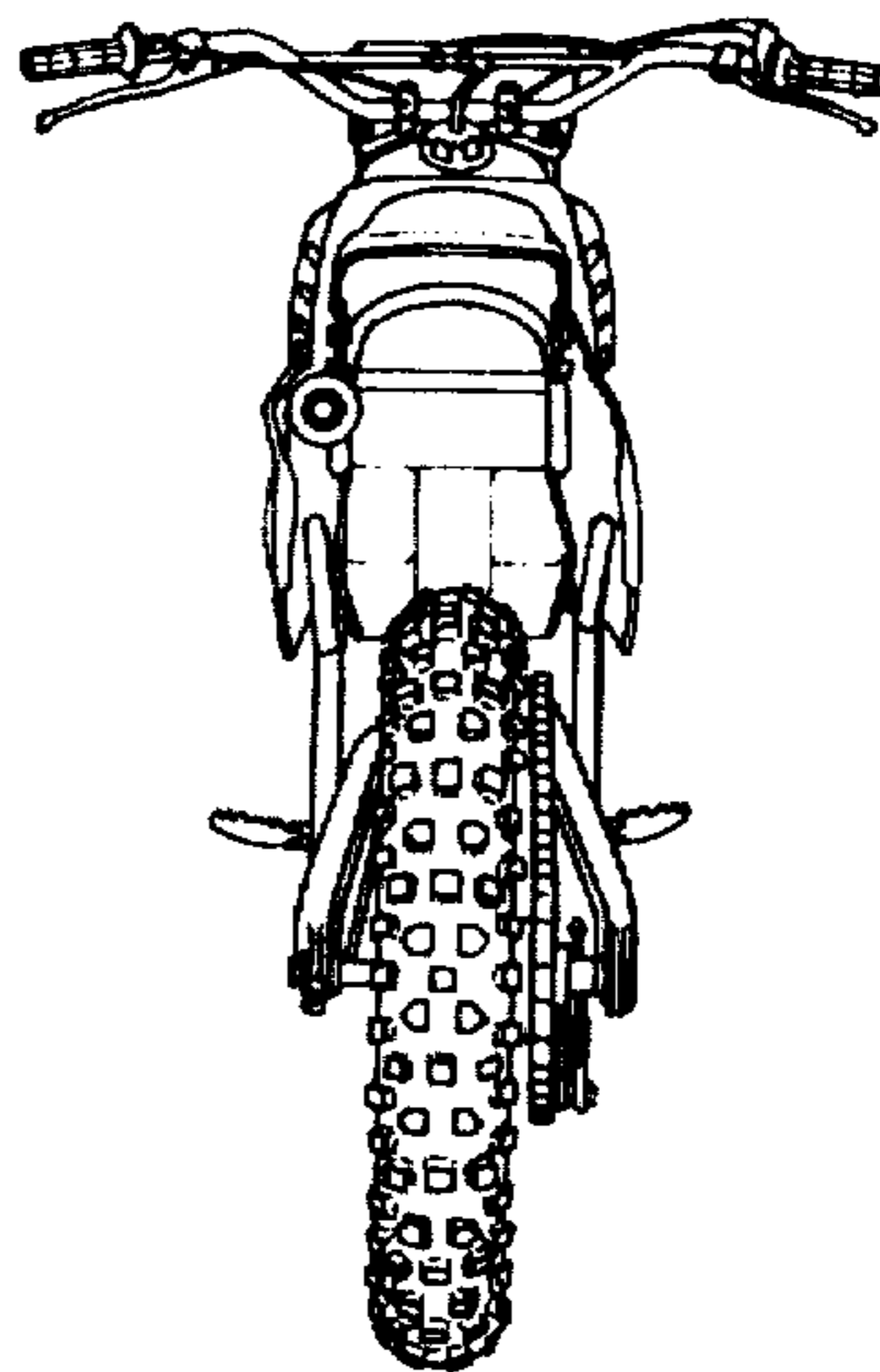

FIG. 5

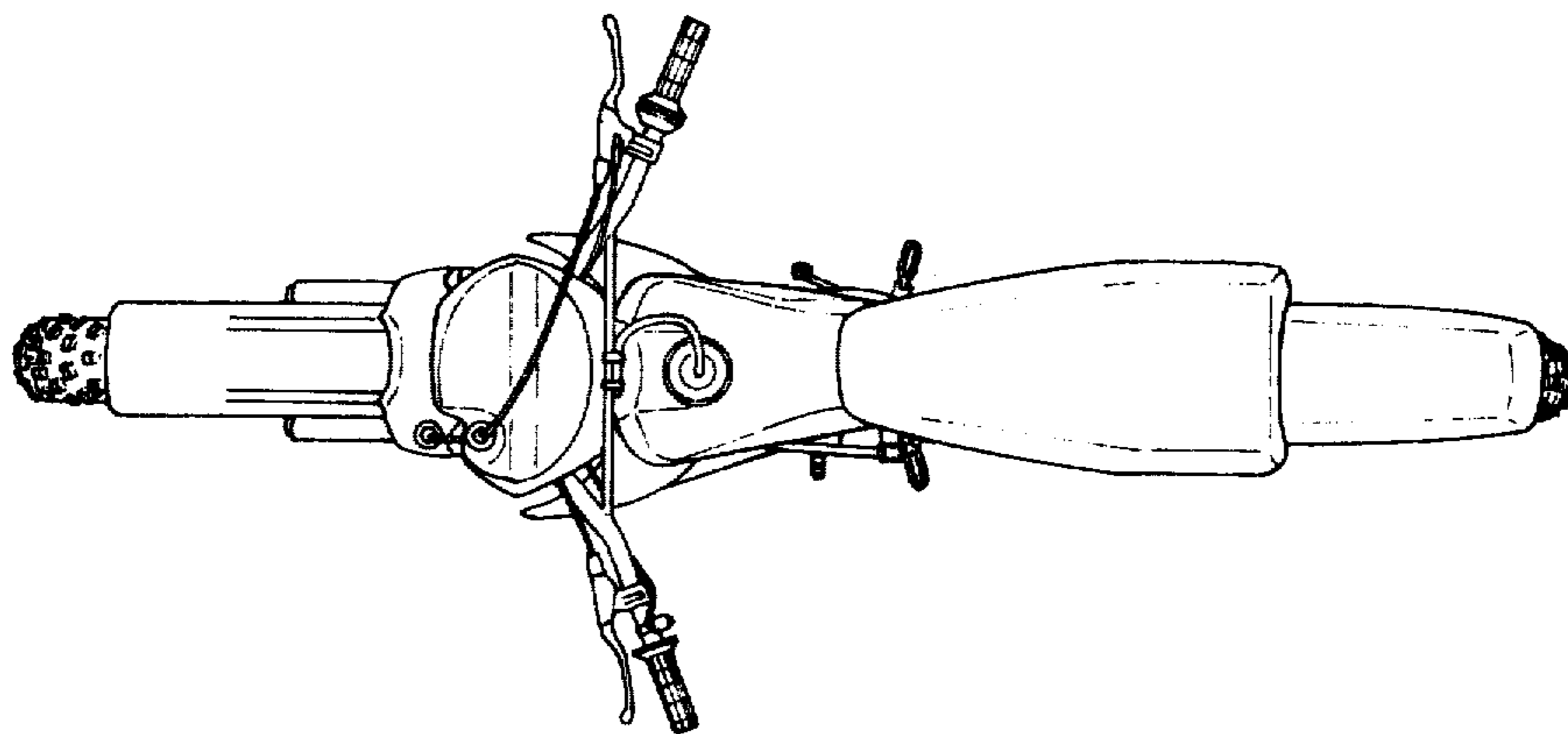

FIG. 6

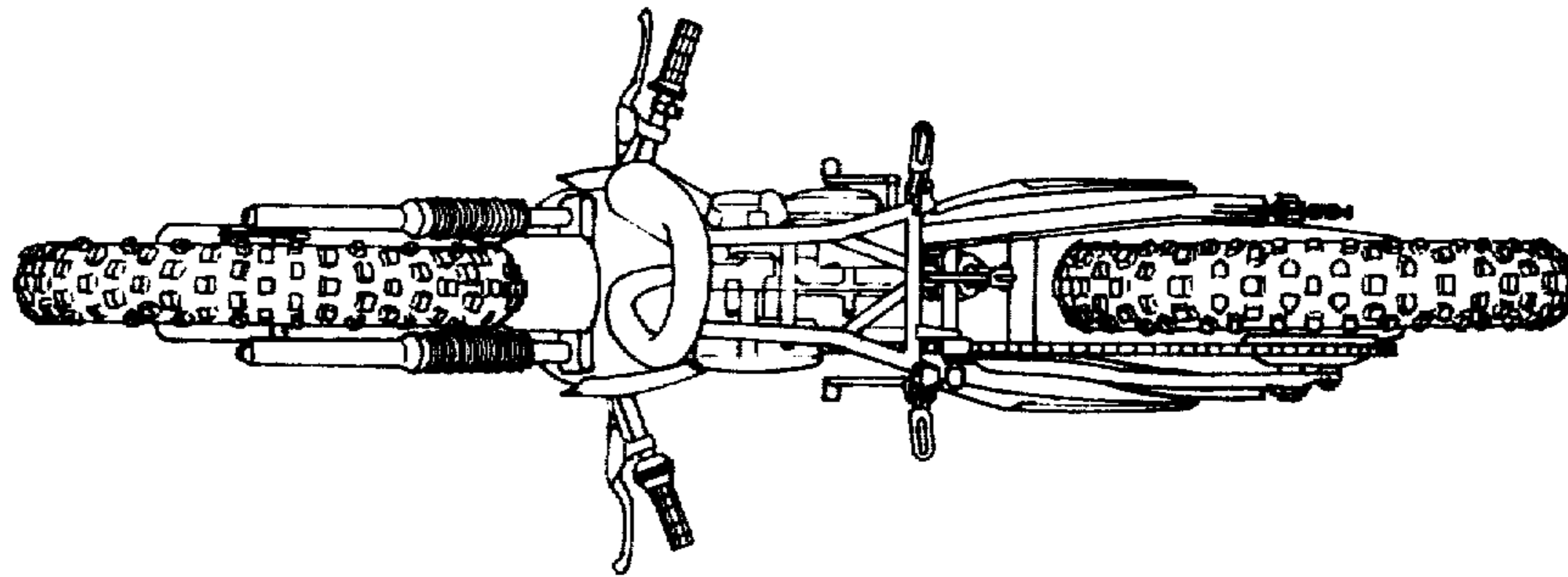

FIG. 7

