

[54] TIRE CHANGER

[75] Inventors: Jim L. Holladay, Nashville; Charles G. Leeper, Antioch, both of Tenn.

[73] Assignee: Hennessy Industries, Inc., Elk Grove Village, Ill.

[\*\*] Term: 14 Years

[21] Appl. No.: 268,200

[22] Filed: May 29, 1981

[51] Int. Cl. .... D15-99

[52] U.S. Cl. .... D15/199

[58] Field of Search ..... D15/199; 157/1.24

[56] References Cited

U.S. PATENT DOCUMENTS

- D. 213,914 4/1969 Simpkins ..... D15/199
- D. 232,763 9/1974 Curtis ..... D15/199
- D. 243,551 3/1977 Wood et al. .... D15/199

- 3,238,989 3/1966 Silvestrani ..... 157/1.24
- 3,528,475 9/1970 Dugesne ..... 157/1.24
- 3,858,637 1/1975 Dugesne ..... 157/1.24

Primary Examiner—B. J. Bullock  
Attorney, Agent, or Firm—Wood, Dalton, Phillips, Mason & Rowe

[57] CLAIM

The ornamental design for a tire changer, as shown and described.

DESCRIPTION

FIG. 1 is a reduced perspective view of a tire changer showing our new design;  
 FIG. 2 is an elevational view taken from the right of FIG. 1;  
 FIG. 3 is an elevational view taken from the left of FIG. 1;  
 FIG. 4 is a top plan view, the bottom being plain and unornamented;  
 FIG. 5 is a rear elevational view.

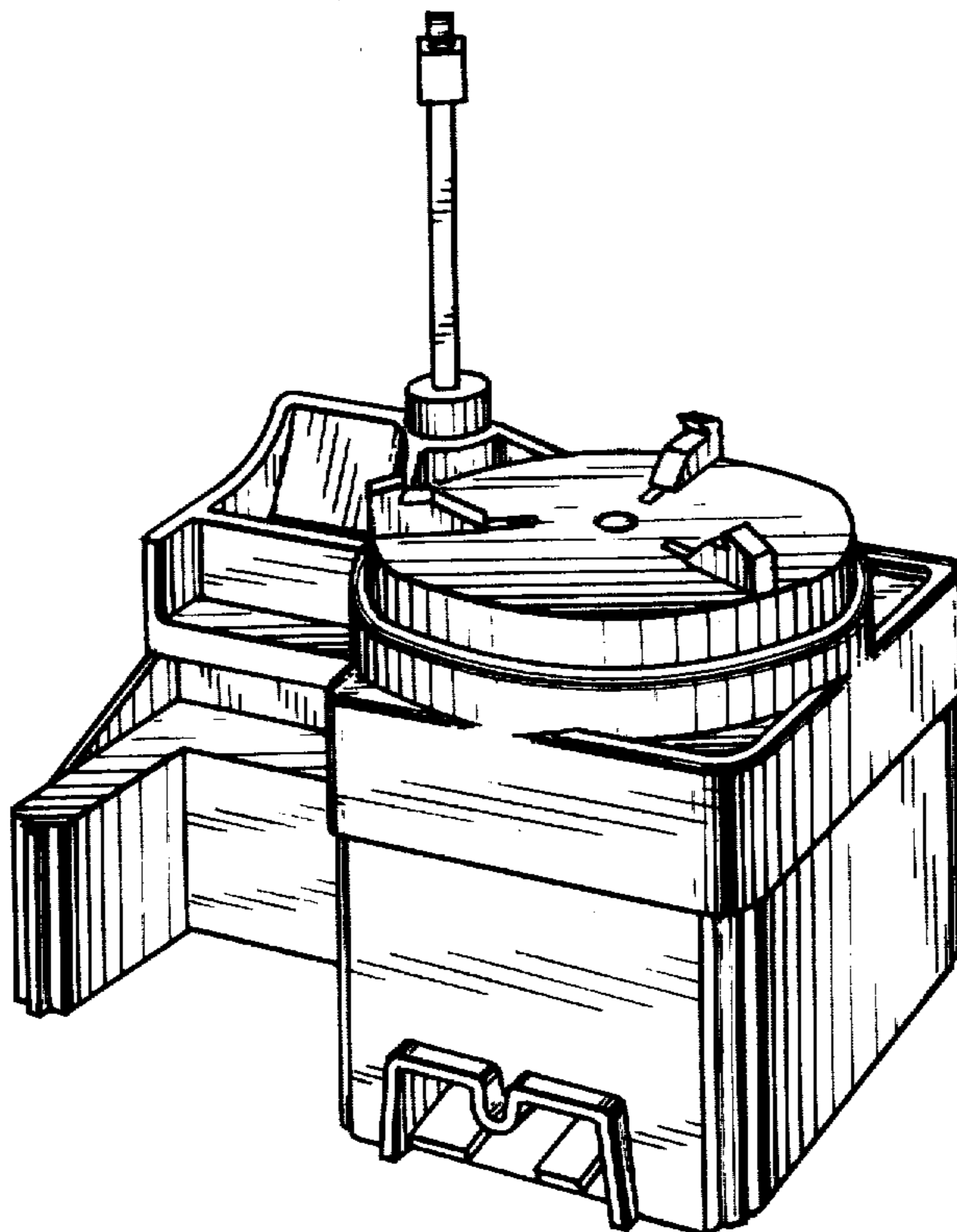

*Fig. 1.*

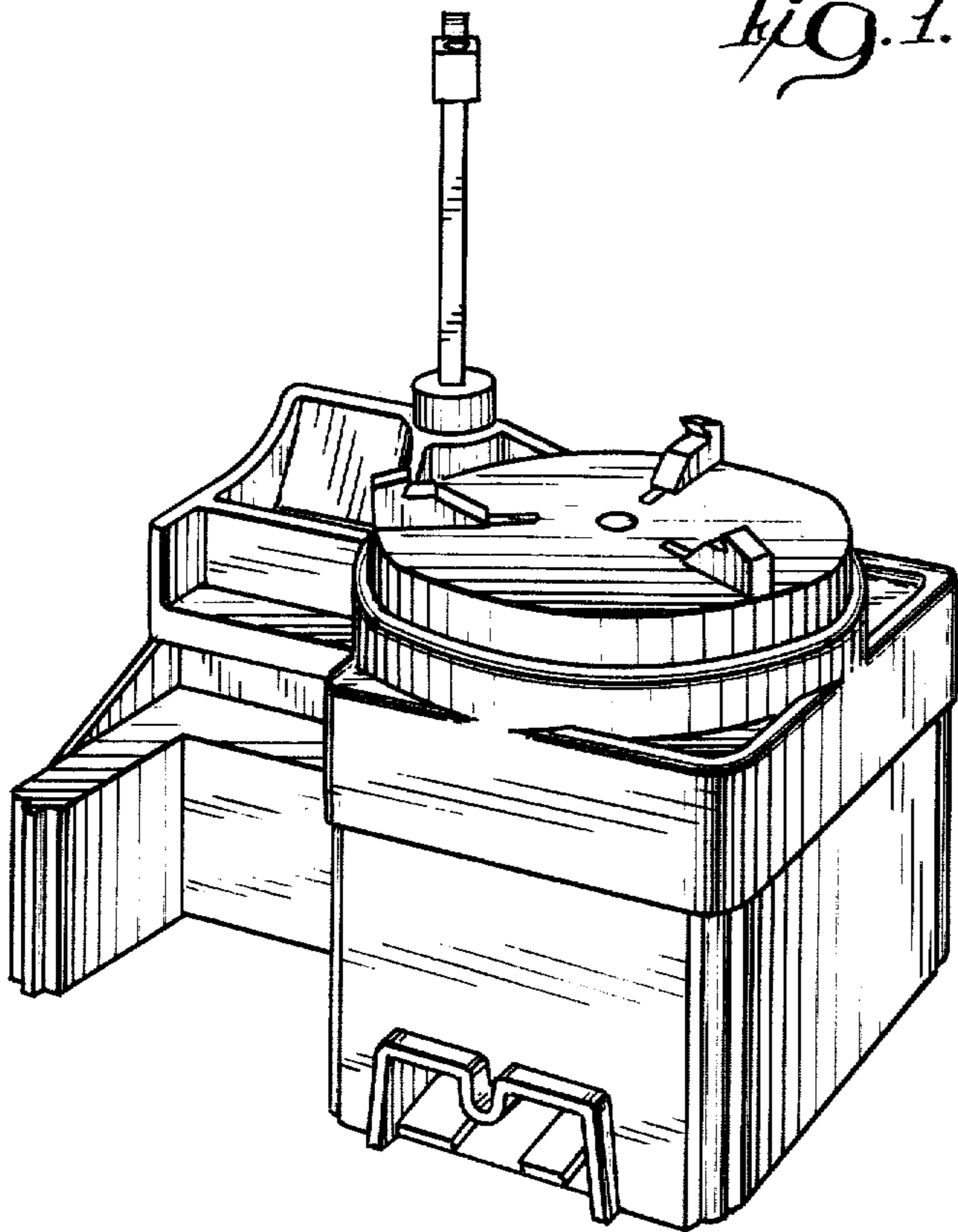

*Fig. 2.*

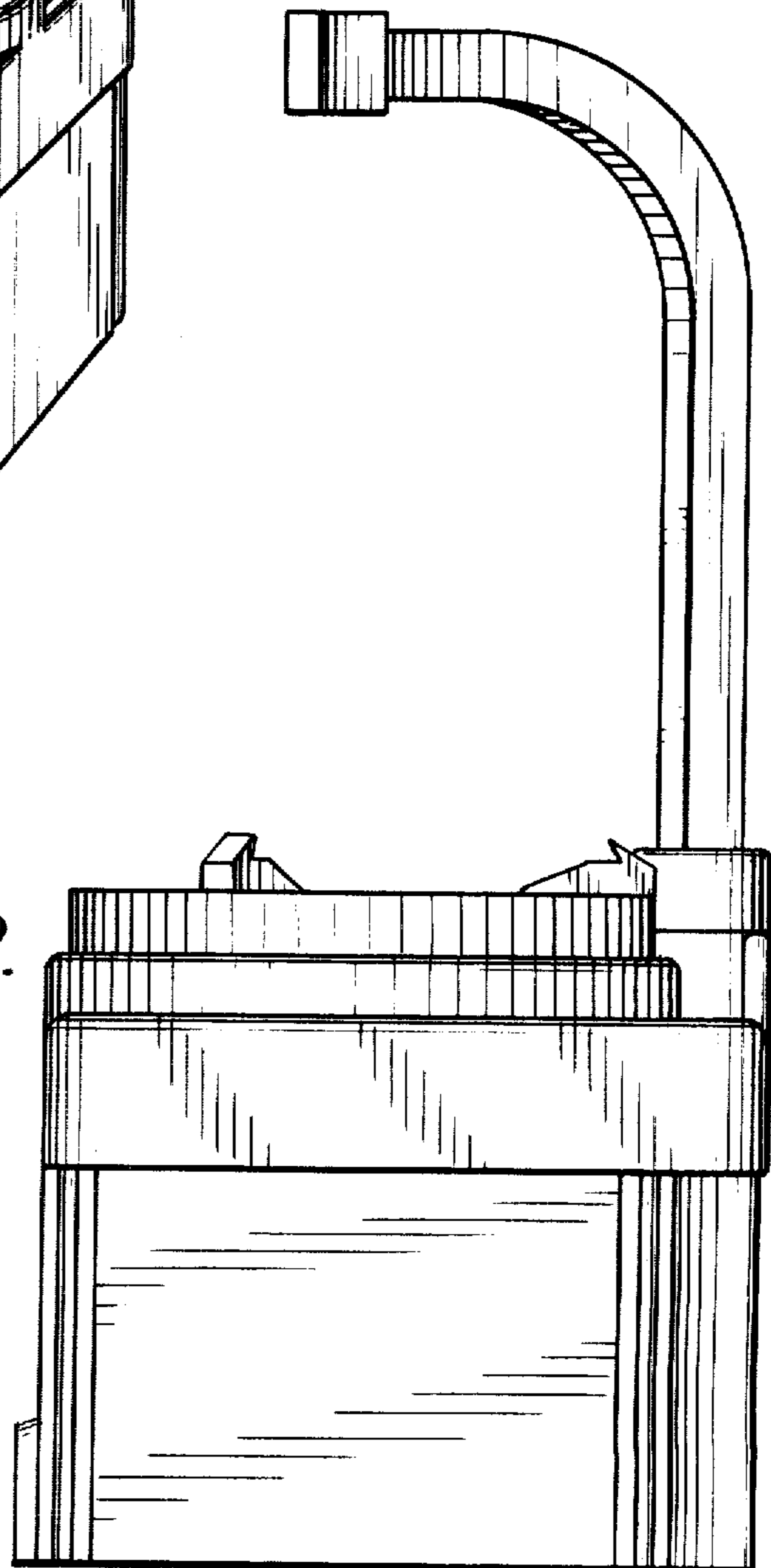

*FIG. 3.*

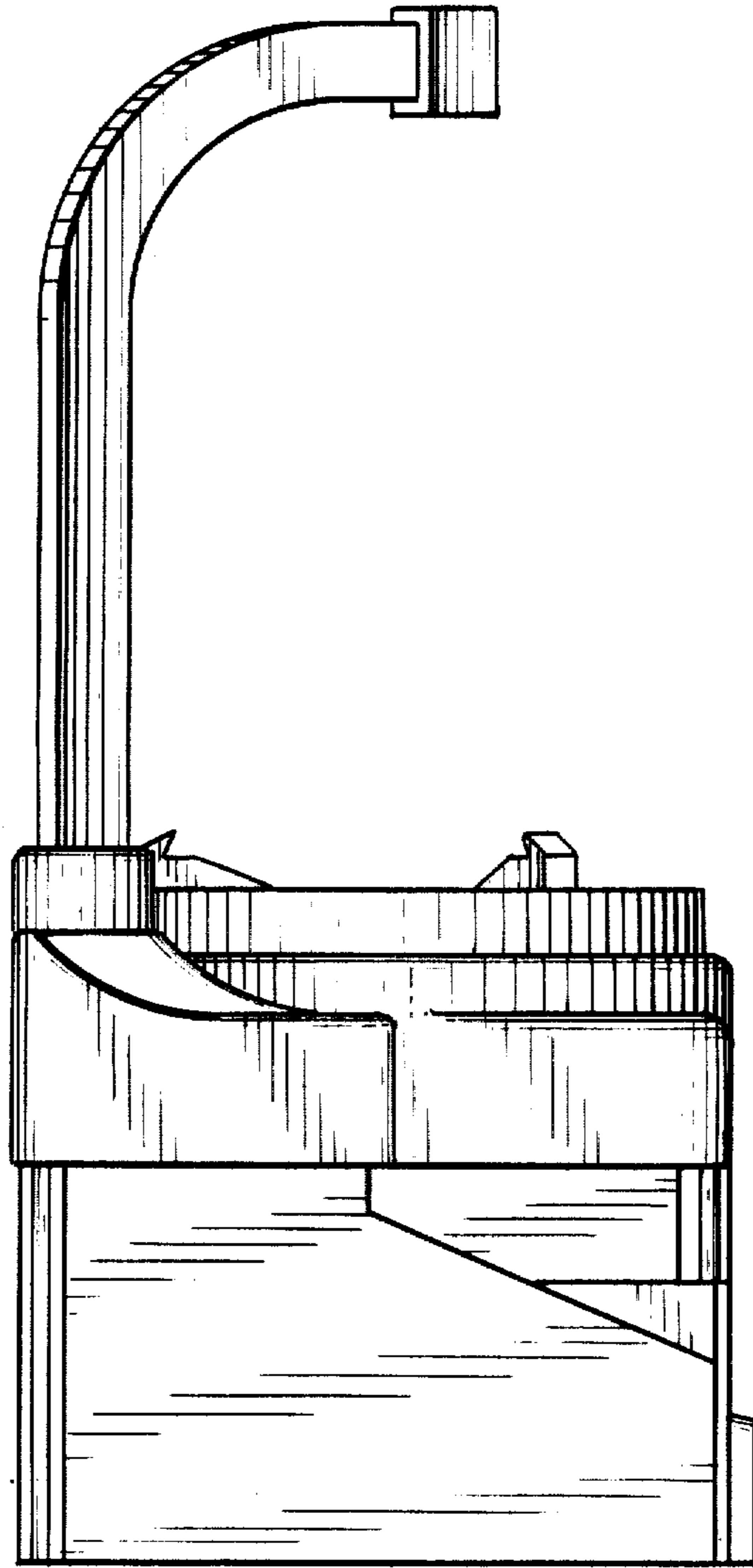

*FIG. 4.*

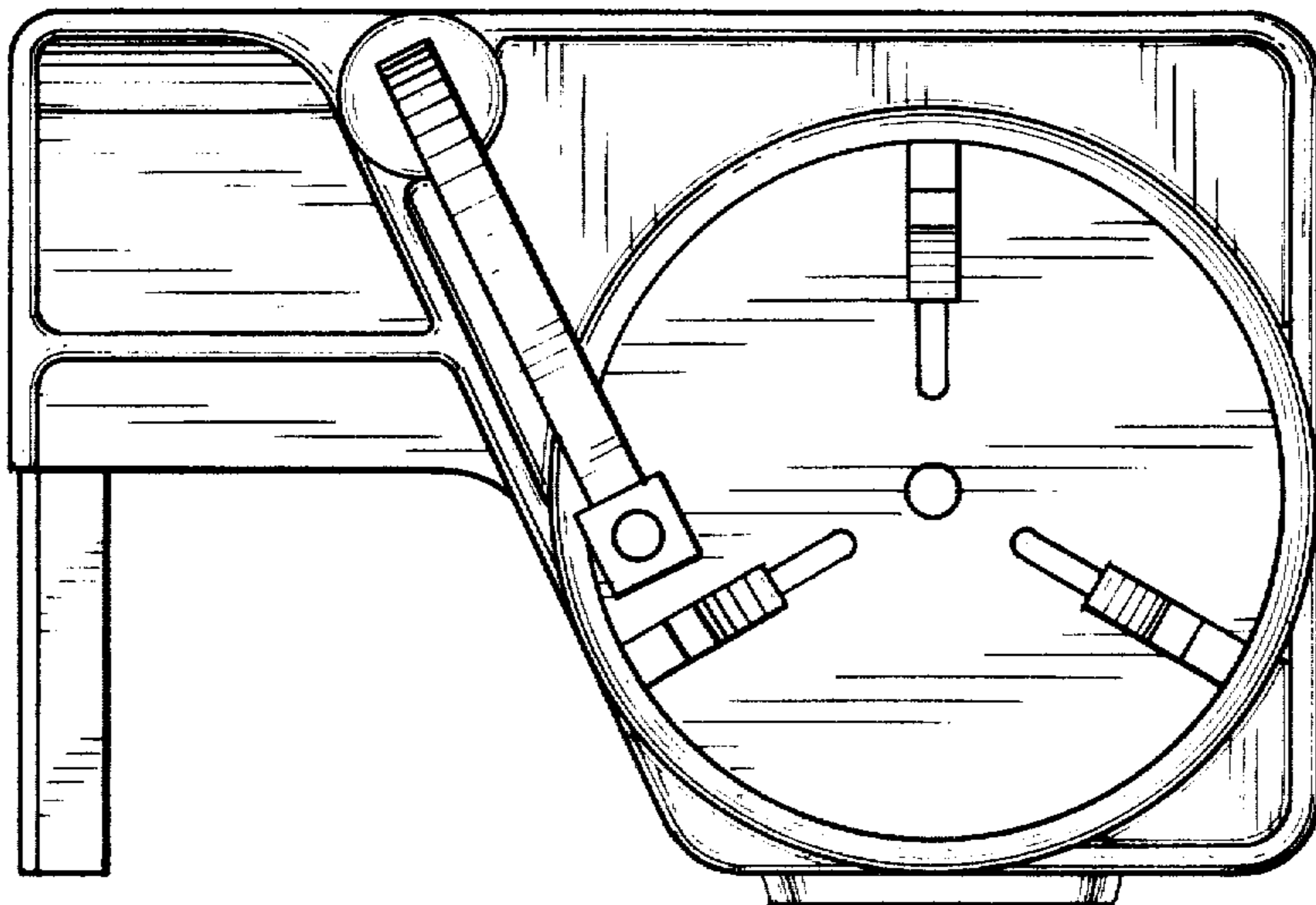

*Fig. 5.*

