

[54] COMBINED SEAT AND BACKREST UNIT

[76] Inventor: Edsel E. Murry, Rte. 1, Box 271-A, Christiana, Tenn. 37037

[**] Term: 14 Years

[21] Appl. No.: 232,875

[22] Filed: Feb. 9, 1981

[51] Int. Cl. D6-06

[52] U.S. Cl. D6/191; D6/31; D6/35; D6/78; D6/197

[58] Field of Search D6/20-32, D6/35, 36, 47-78, 191, 197

[56] References Cited

U.S. PATENT DOCUMENTS

- D. 160,105 9/1950 Michelson D6/35
- D. 214,164 5/1969 Sickler D6/20
- D. 224,192 7/1972 Grosfillex D6/70
- D. 233,720 11/1974 Koepke D6/197
- D. 248,524 7/1978 Gabourie D6/78 X
- D. 260,065 8/1981 Petersen D6/197

OTHER PUBLICATIONS

Design Catalog, May 1979, p. 9, Chair bottom right by Brever.

Sears Roebuck & Co. Cat. S & S 1979, p. 1134, Stool No. 5.

Primary Examiner—Bruce W. Dunkins

Attorney, Agent, or Firm—Sheridan, Ross & McIntosh

[57] CLAIM

The ornamental design for the combined seat and backrest unit, as shown and described.

DESCRIPTION

FIG. 1 is a perspective view of a combined seat and backrest unit showing my design;
 FIG. 2 is a top plan view thereof;
 FIG. 3 is a bottom plan view thereof;
 FIG. 4 is a front elevational view thereof;
 FIG. 5 is a side elevational view thereof;
 FIG. 6 is a rear elevational view thereof;
 FIG. 7 is a perspective view of a further embodiment of the combined seat and backrest unit showing my design;
 FIG. 8 is a top plan view of the embodiment of FIG. 7; and
 FIG. 9 is a bottom plan view of the embodiment of FIG. 7.

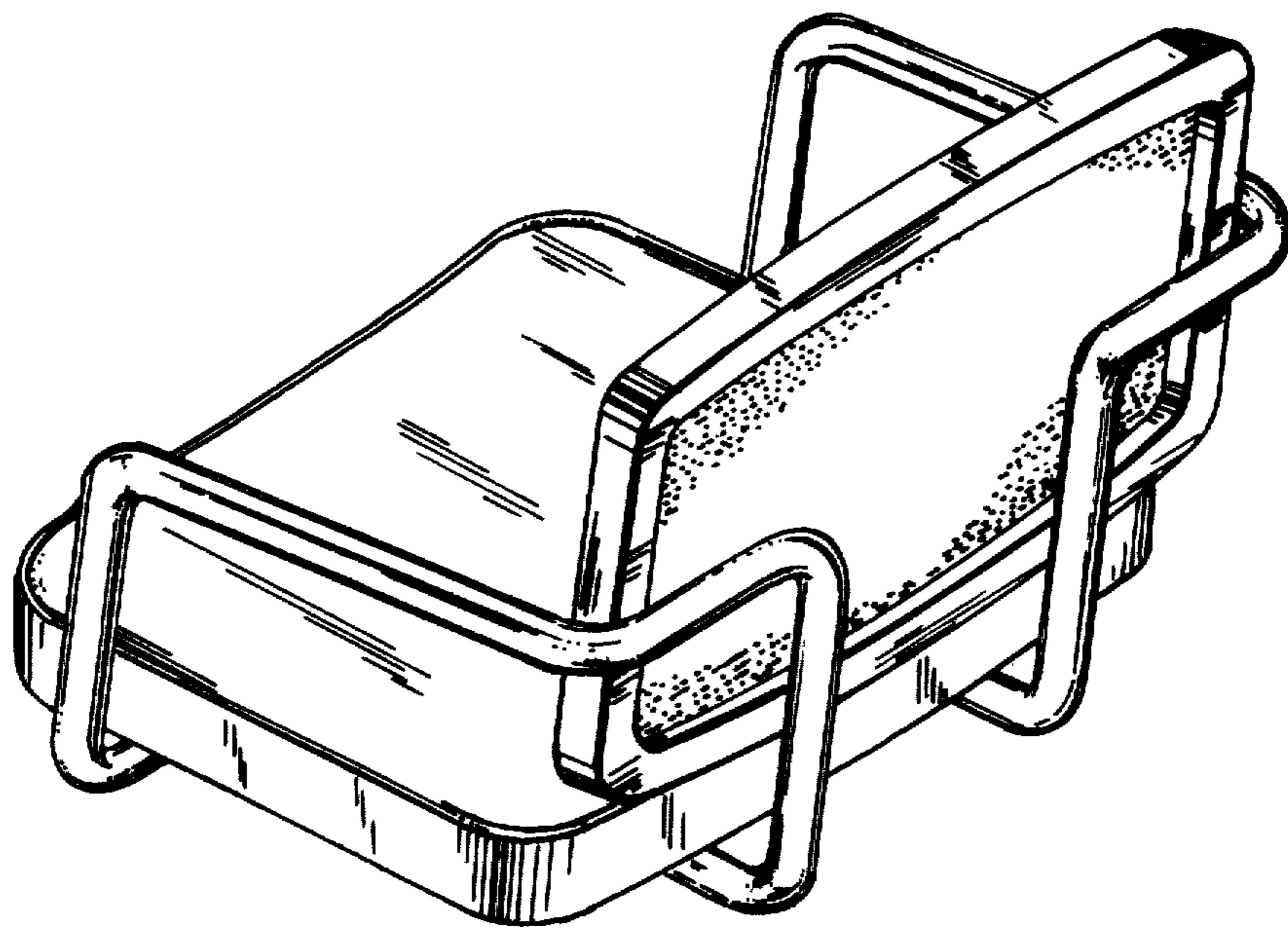

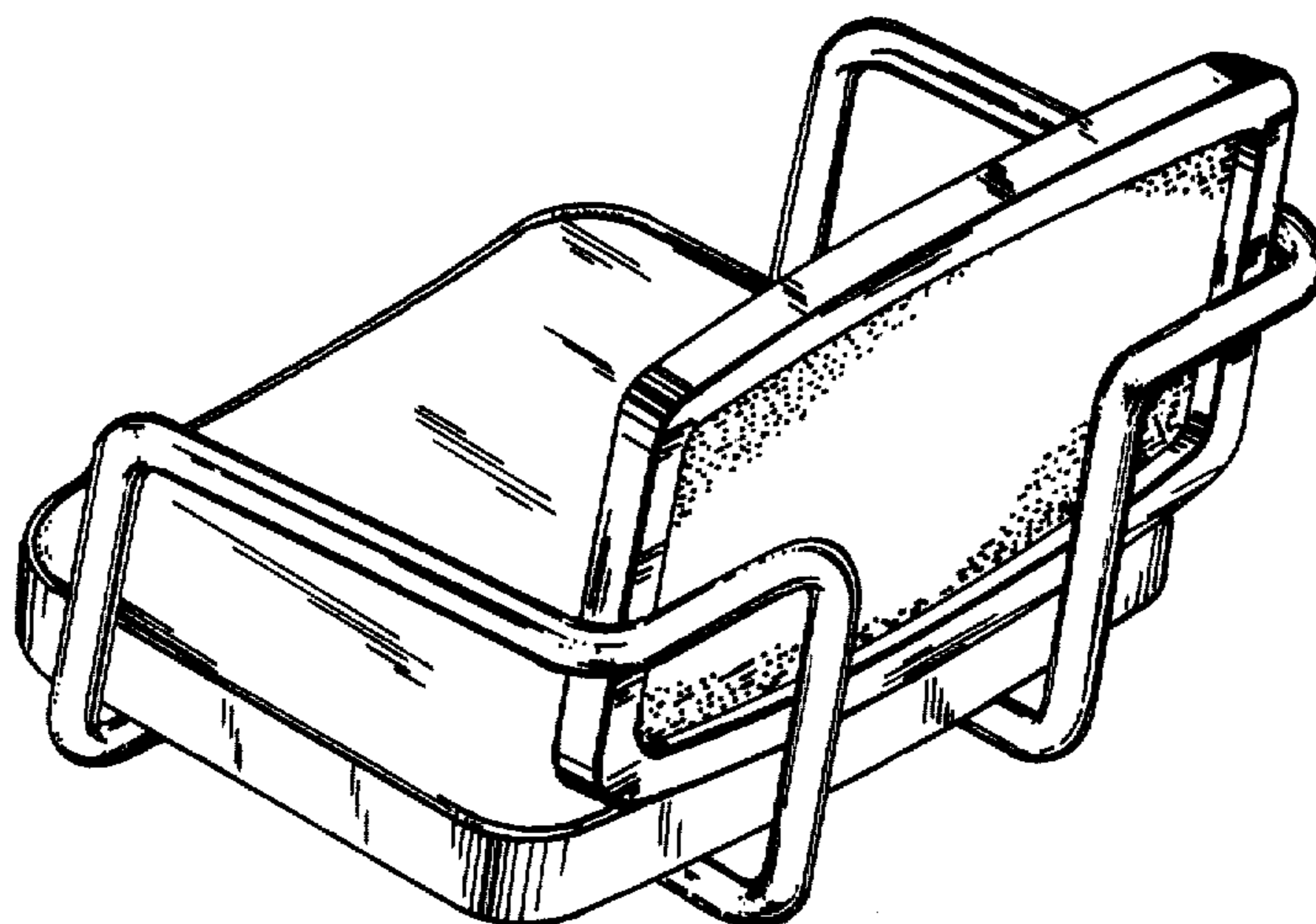

Fig-1

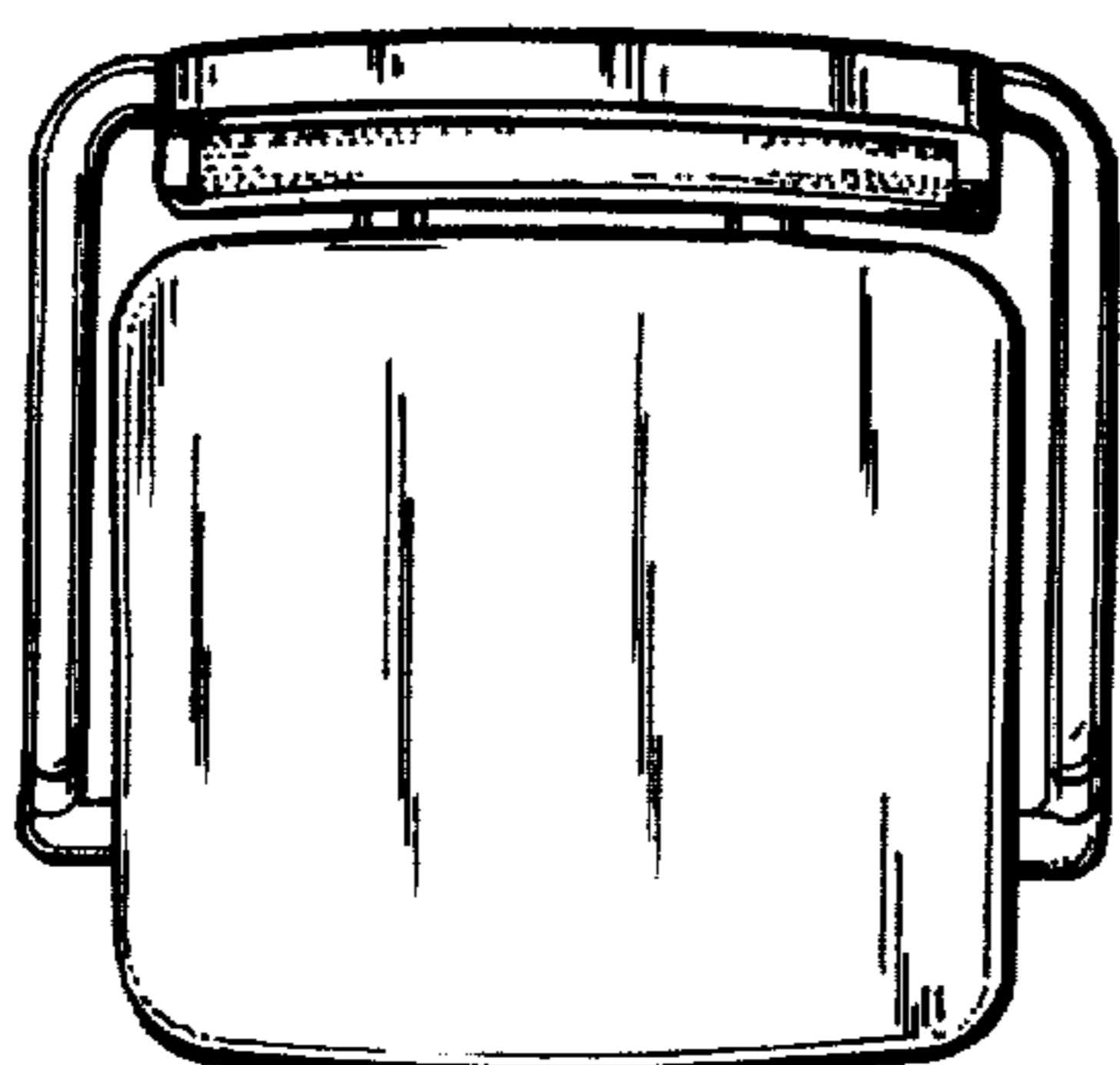

Fig-2

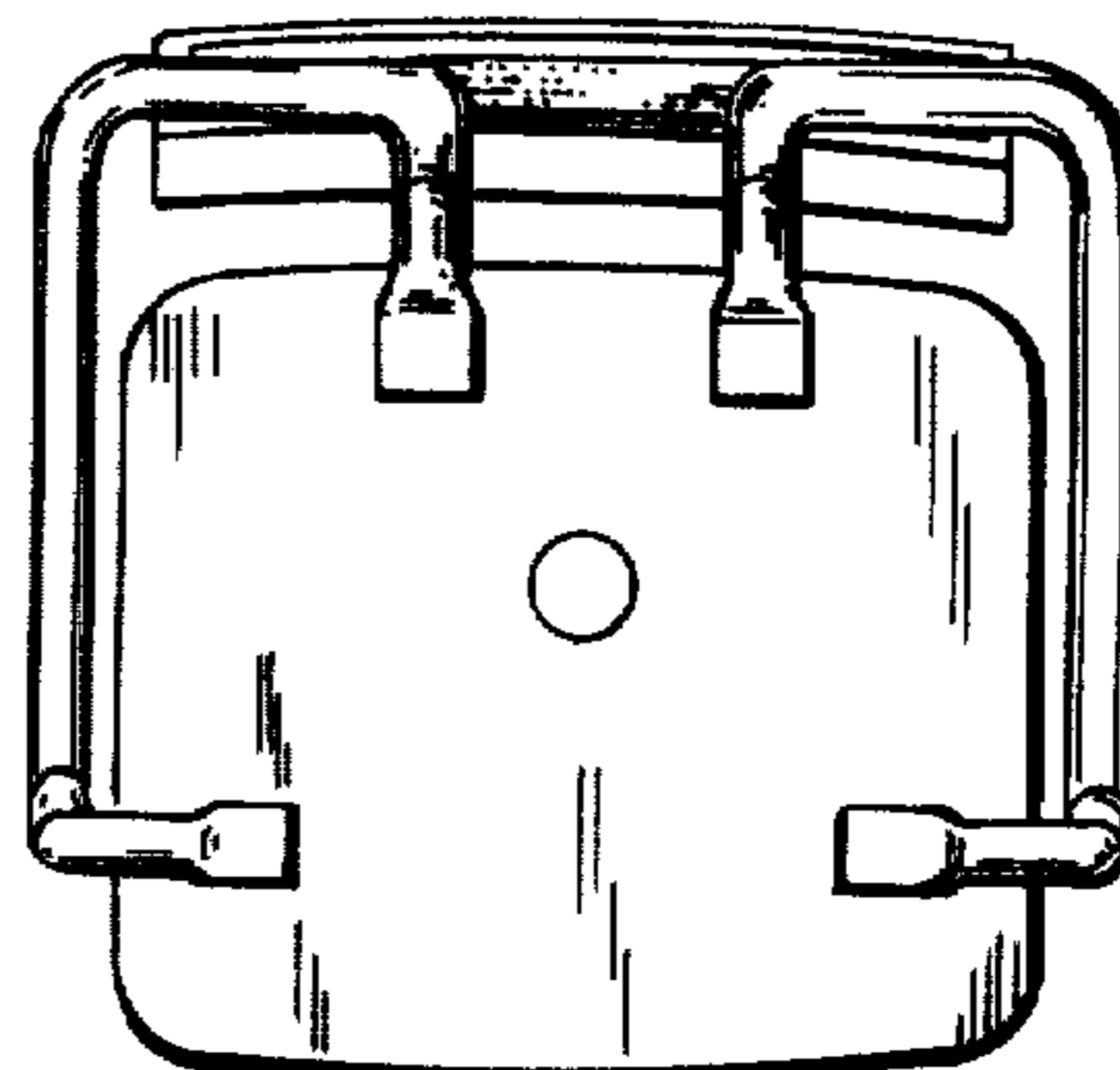

Fig-3

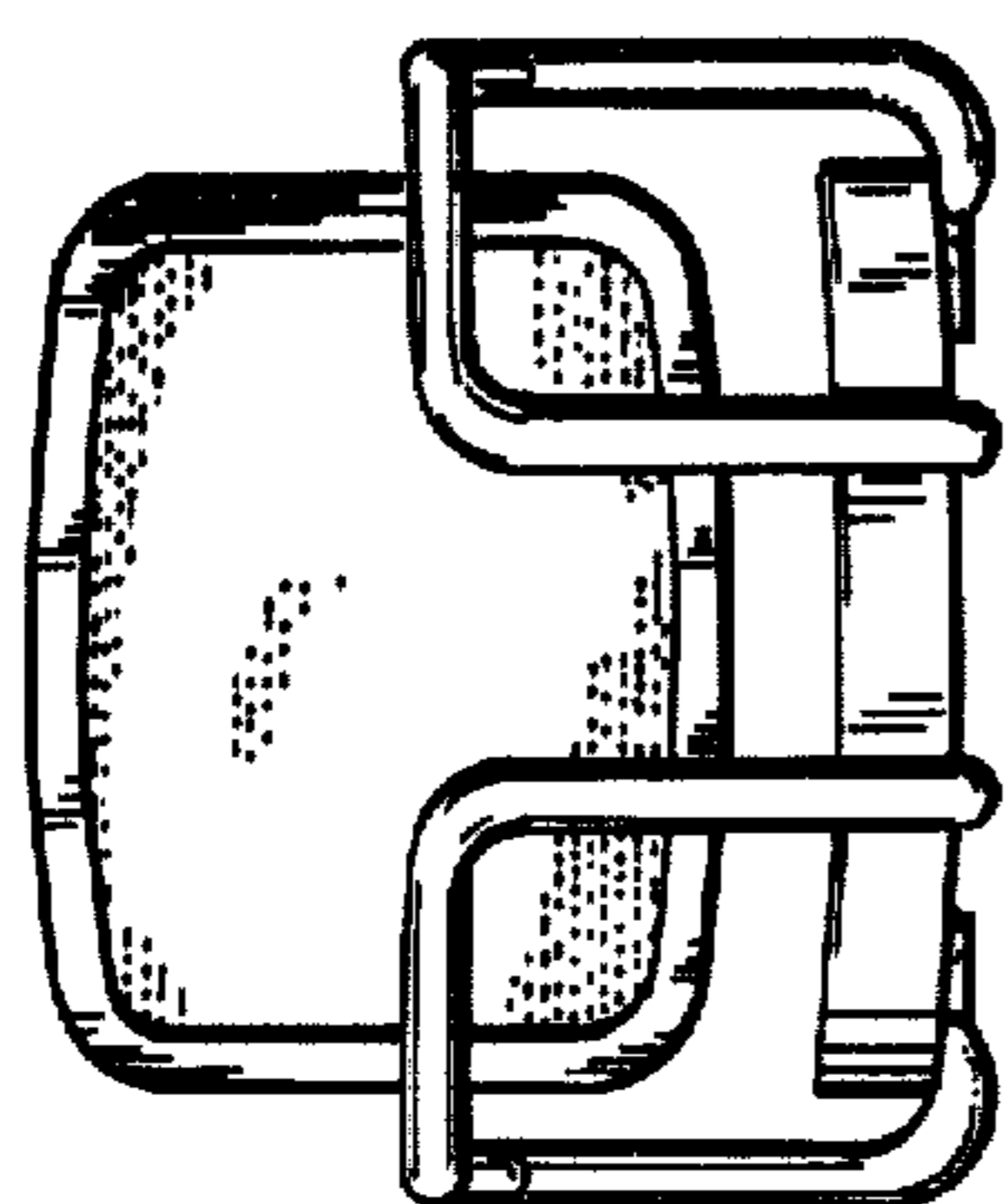

Fig-6

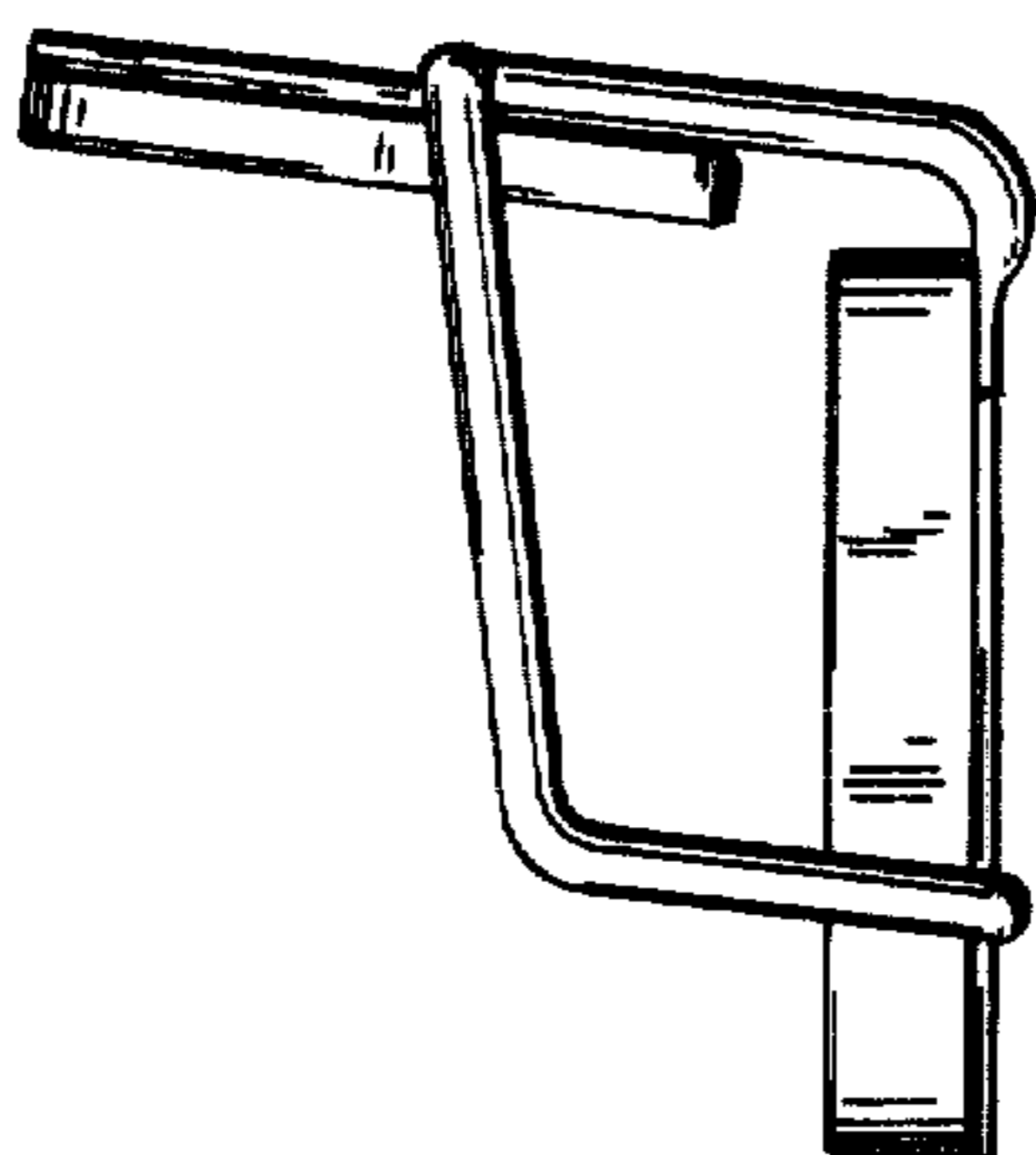

Fig-5

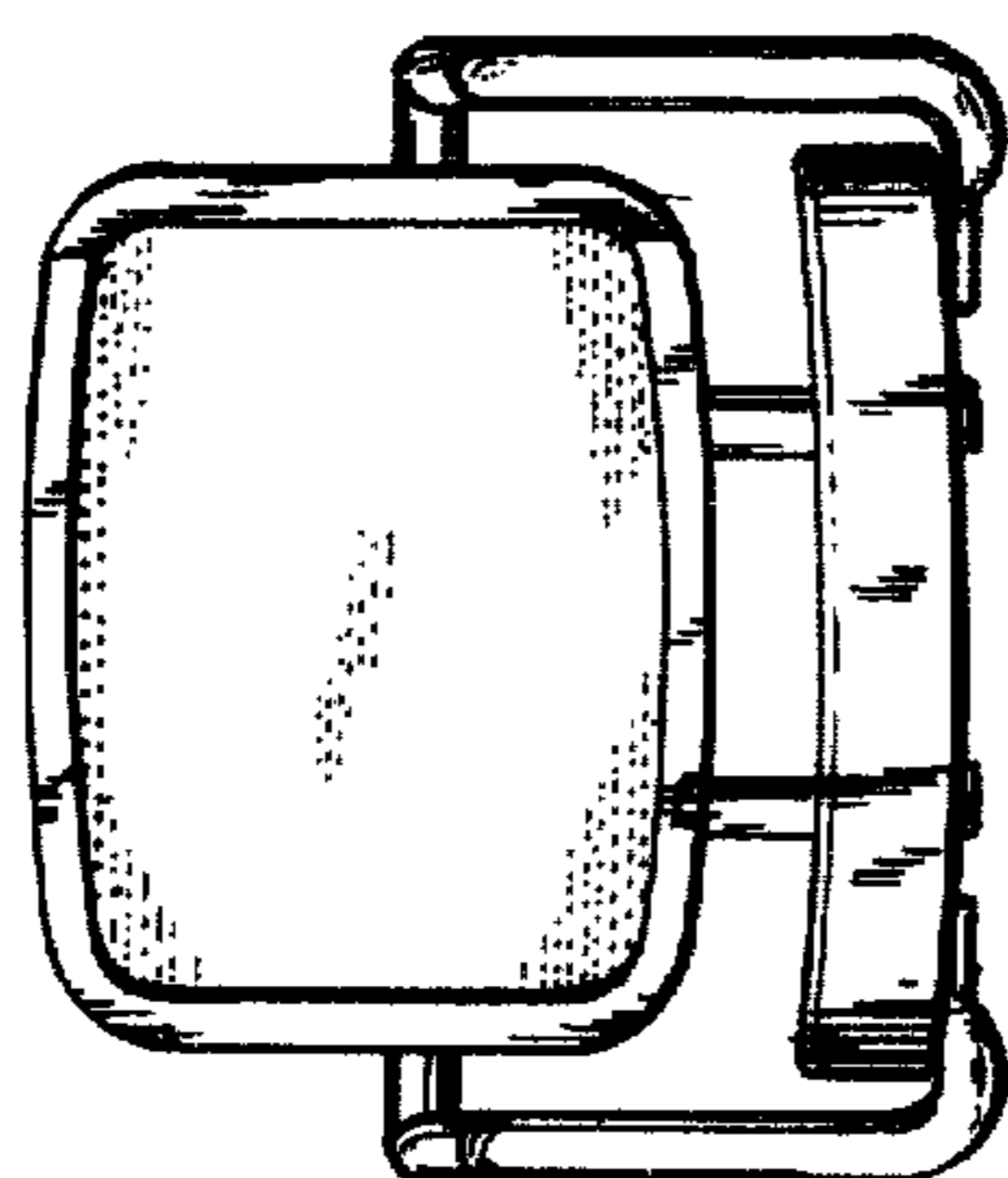
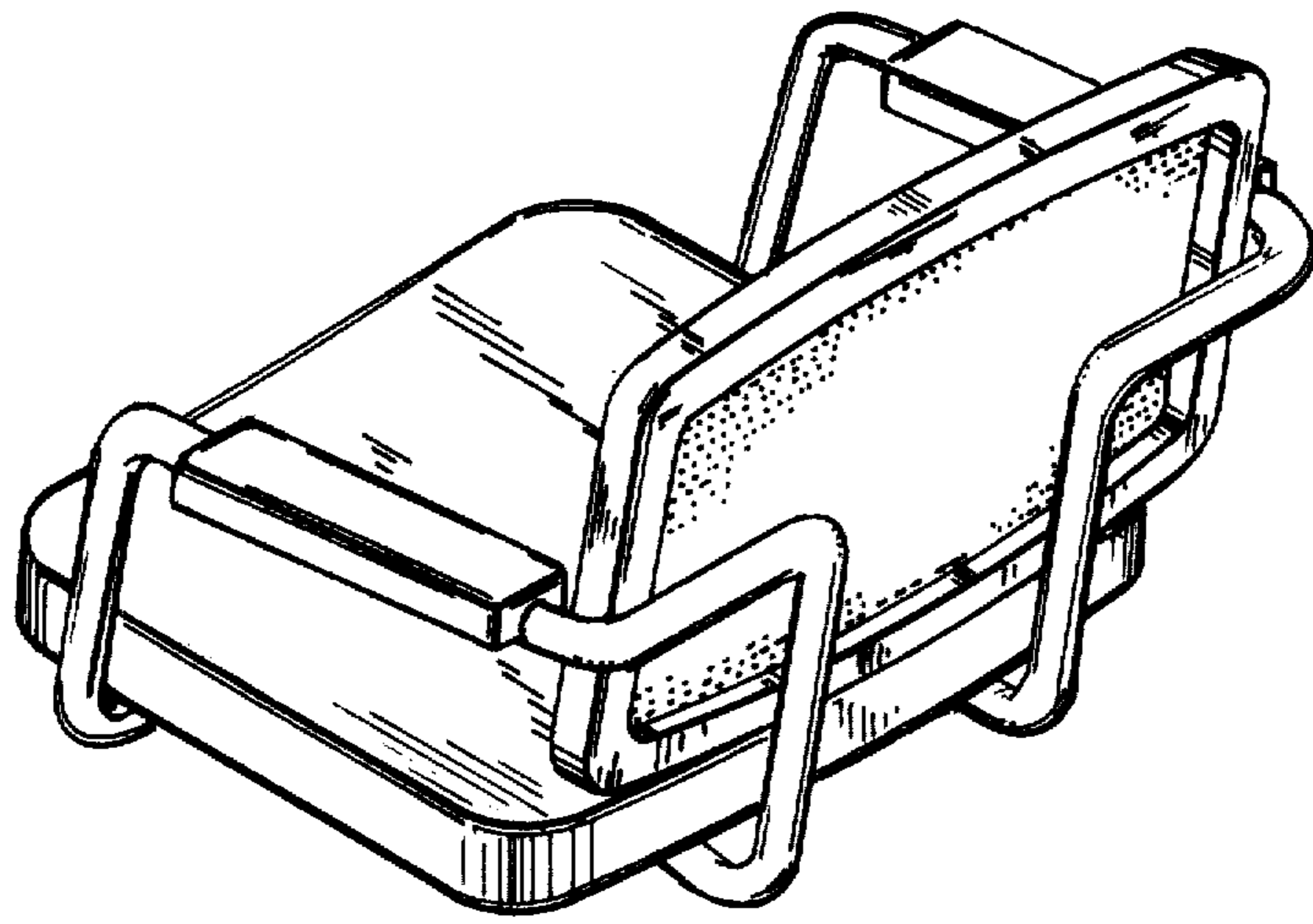
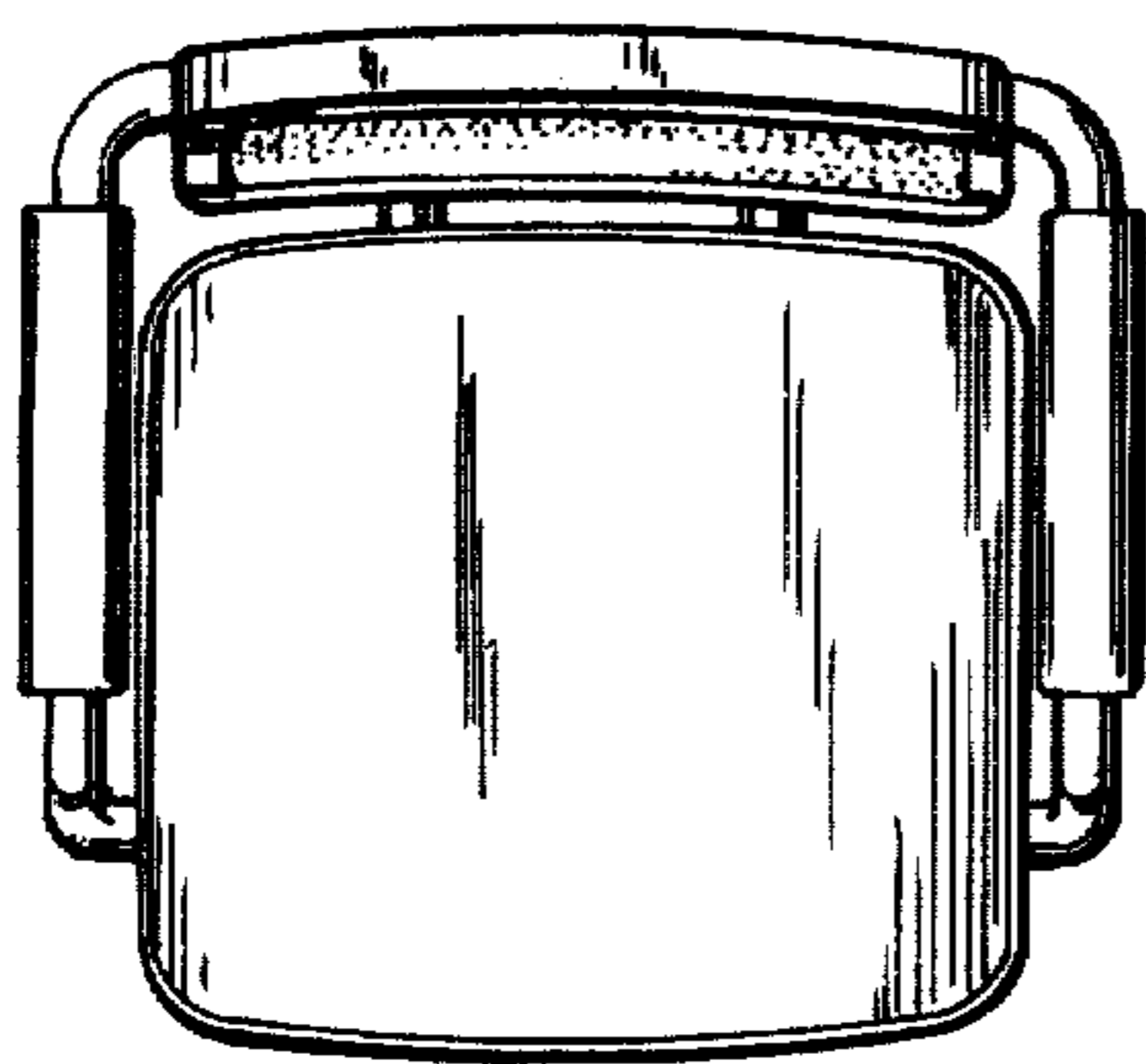

Fig-4



Fig_7



Fig_8

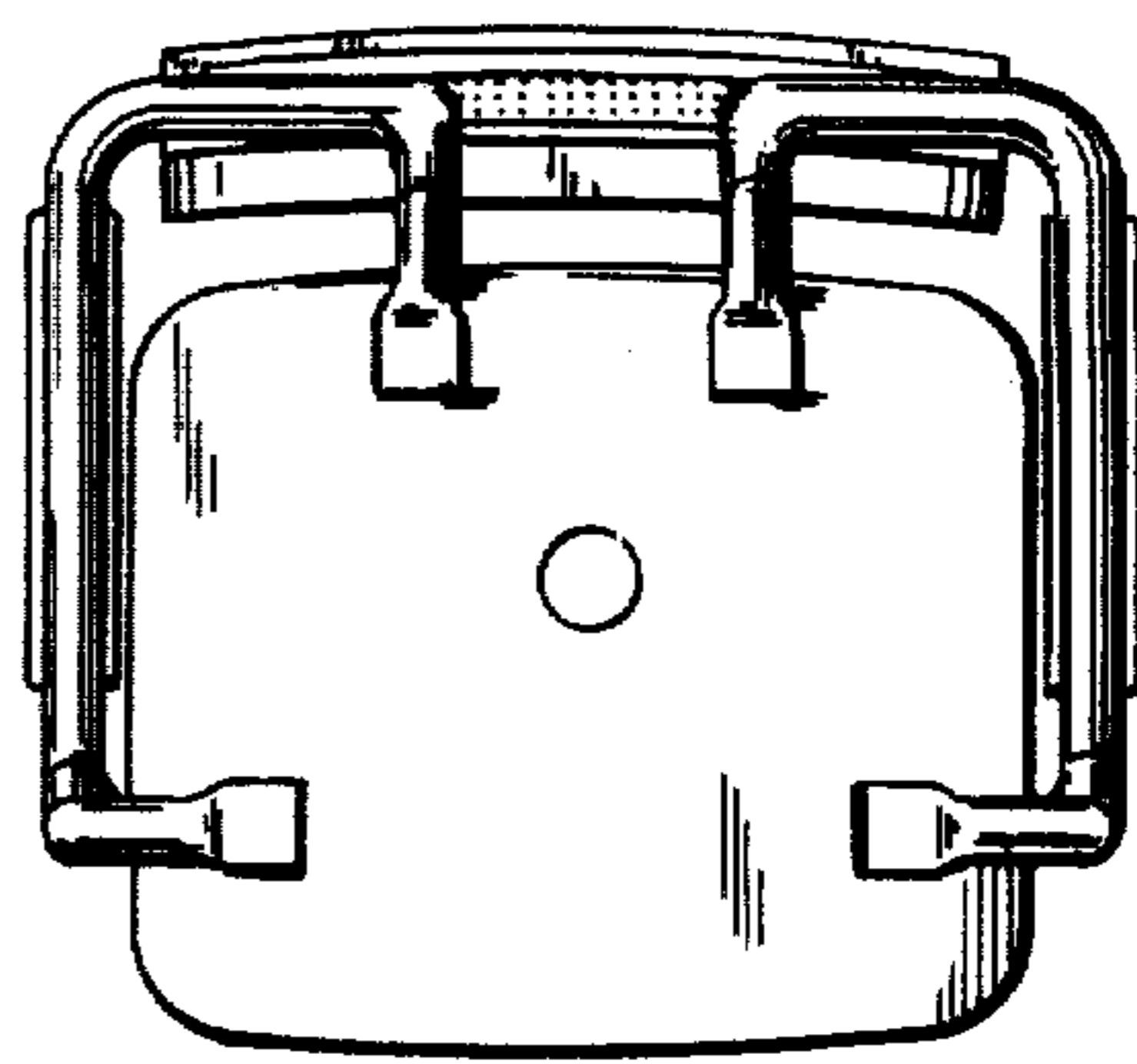

Fig_9