

[54] **WHEEL CENTER**
[76] Inventor: **Donald F. Morgan**, 133 E. Central,
Zeeland, Mich. 49464
[**] Term: **14 Years**
[21] Appl. No.: **198,917**
[22] Filed: **Oct. 20, 1980**
[51] Int. Cl. **D12-16**
[52] U.S. Cl. **D12/204**
[58] Field of Search **D12/135, 204, 211, 212;**
301/63 PW, 64 R, 64 SD, 65

[56] **References Cited**

U.S. PATENT DOCUMENTS

D. 192,417	3/1962	Hulterstrum	D12/135
D. 234,131	1/1975	Woelffer	D12/135
D. 235,433	6/1975	May et al.	D12/211
D. 239,619	4/1976	May et al.	D12/204
D. 243,170	1/1977	May et al.	D12/211
3,604,756	9/1971	Gruber	301/63 PW
4,111,618	9/1978	Thibault	301/63 PW

Primary Examiner—James M. Gandy
Attorney, Agent, or Firm—Price, Heneveld, Huizenga & Cooper

[57] **CLAIM**
The ornamental design for a wheel center, substantially as shown and described.

DESCRIPTION

FIG. 1 is a side elevation view of a wheel center showing my new design;
FIG. 2 is a top plan view thereof on a reduced scale;
FIG. 3 is a sectional view taken along the plane III—III of FIG. 1;
FIG. 4 is a sectional view taken along the plane IV—IV of FIG. 1 and rotated 67.5 degrees counterclockwise; and
FIG. 5 is a sectional view taken along the plane V—V of FIG. 1 and rotated 90 degrees counterclockwise.
The opposite side of the wheel center is the same in appearance as FIG. 1 except the ridges and valleys are rotated 45 degrees.

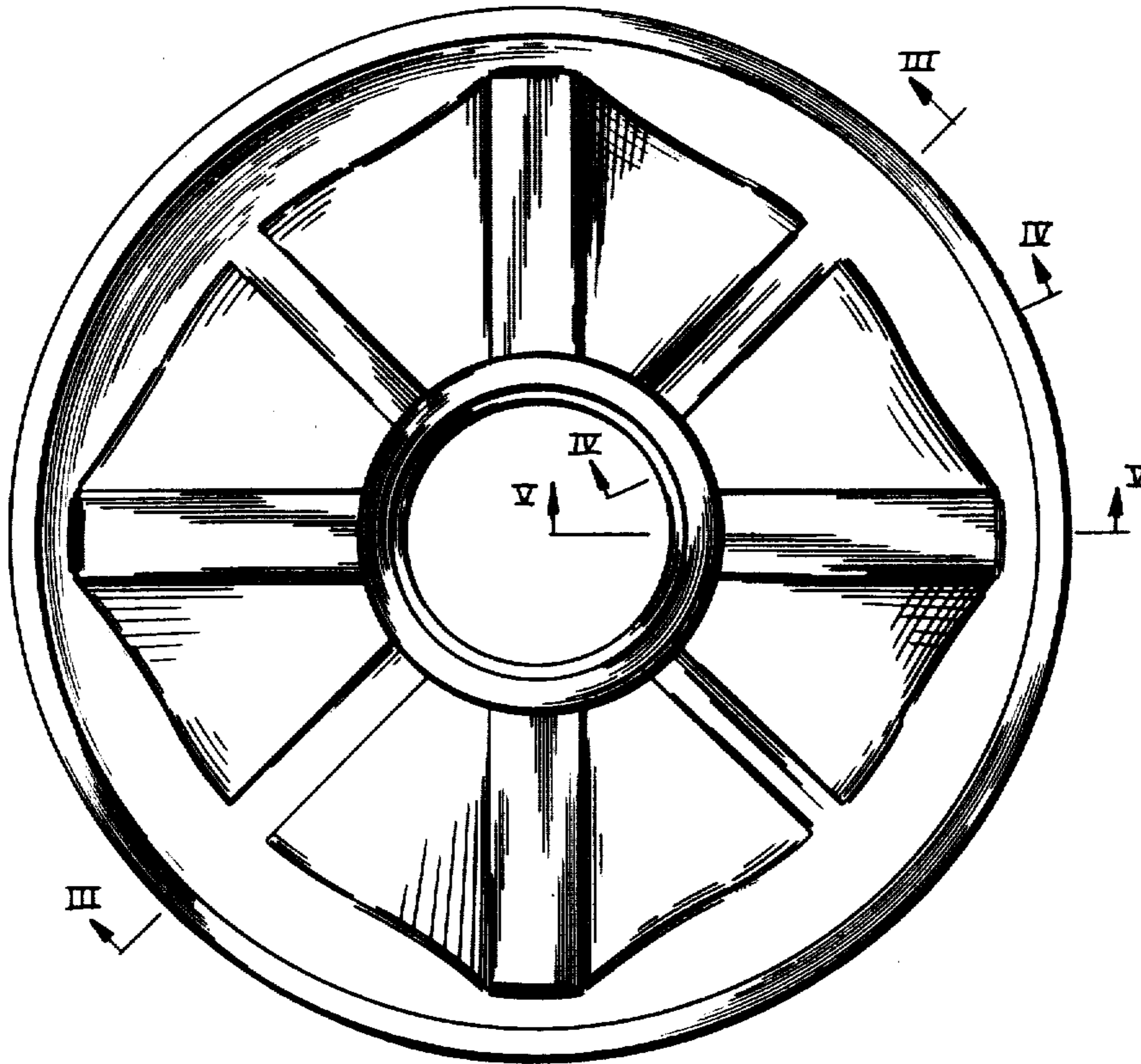

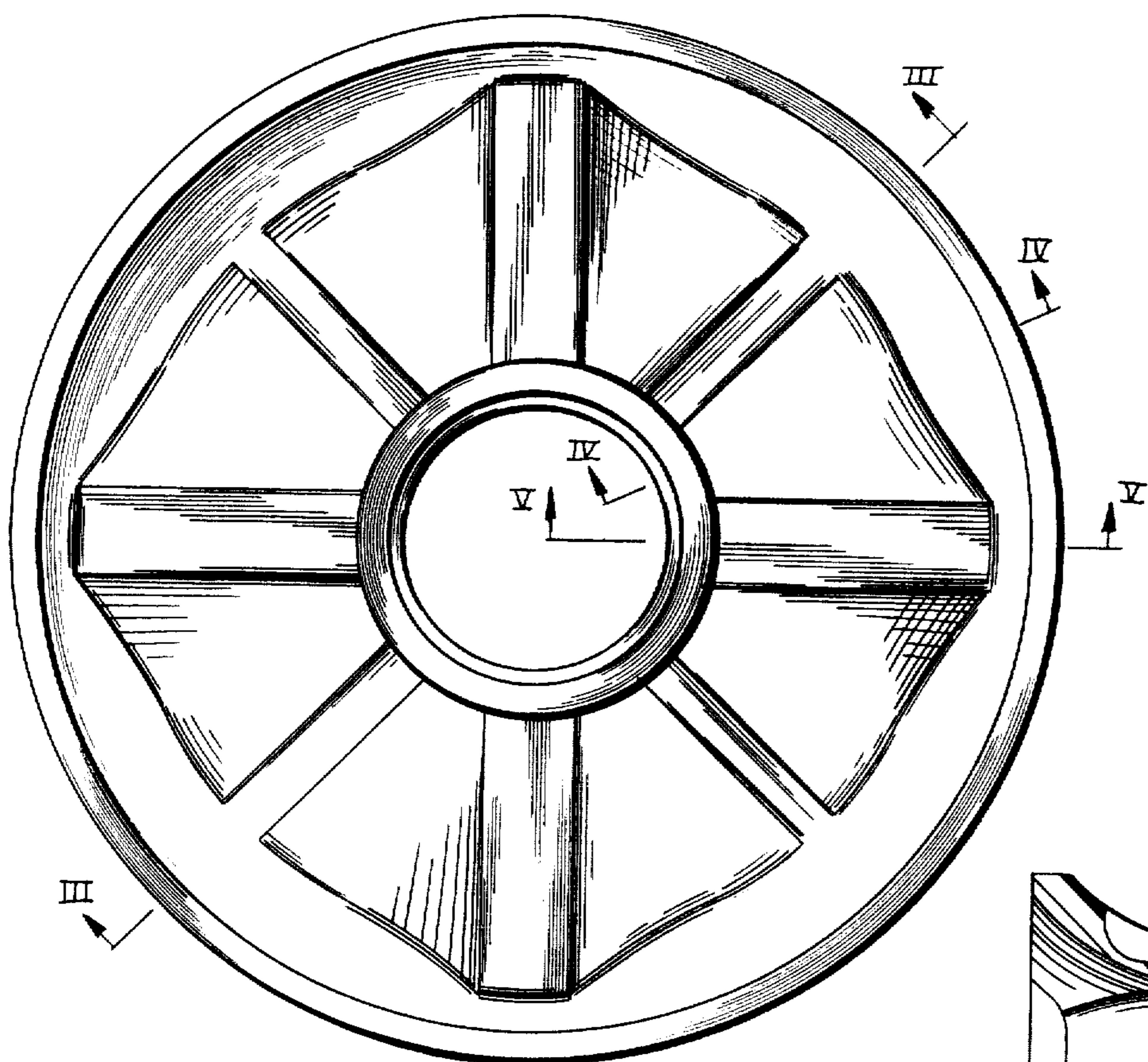

Fig. 1.

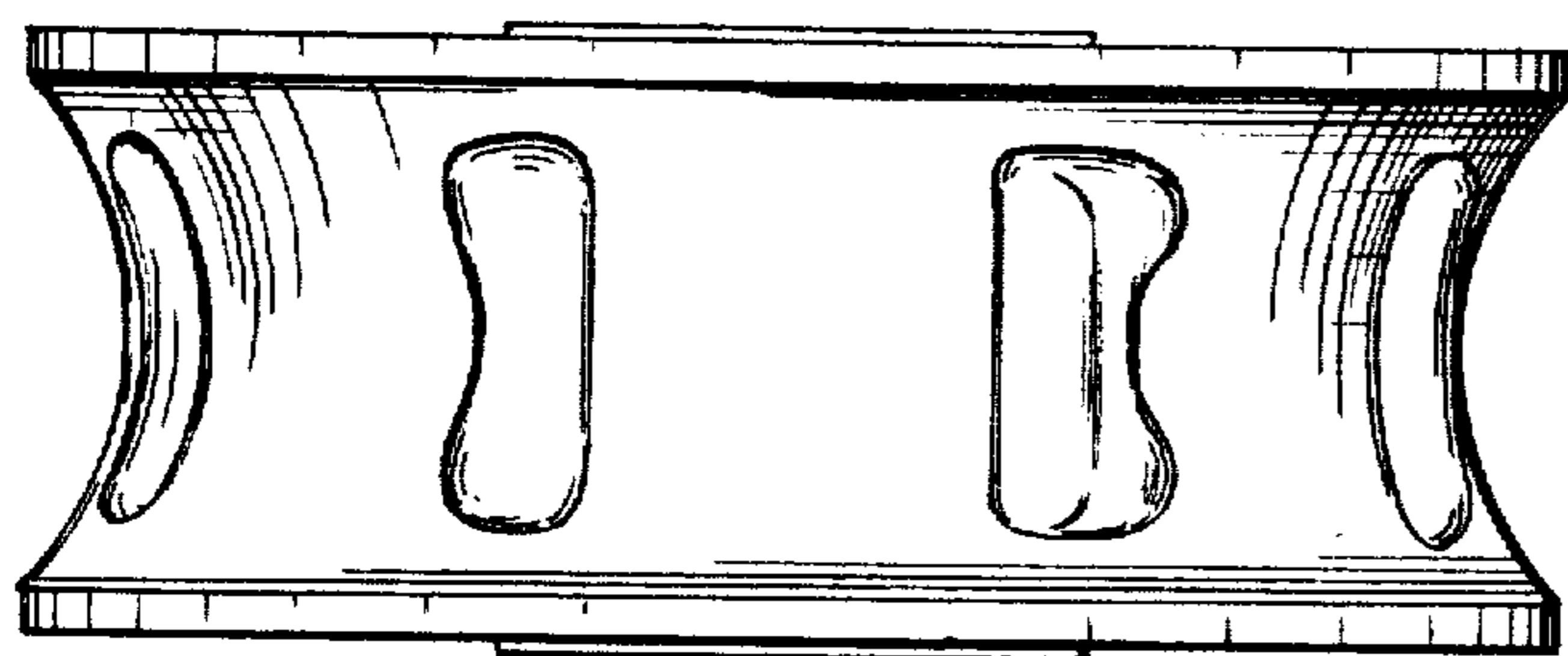

Fig. 2.

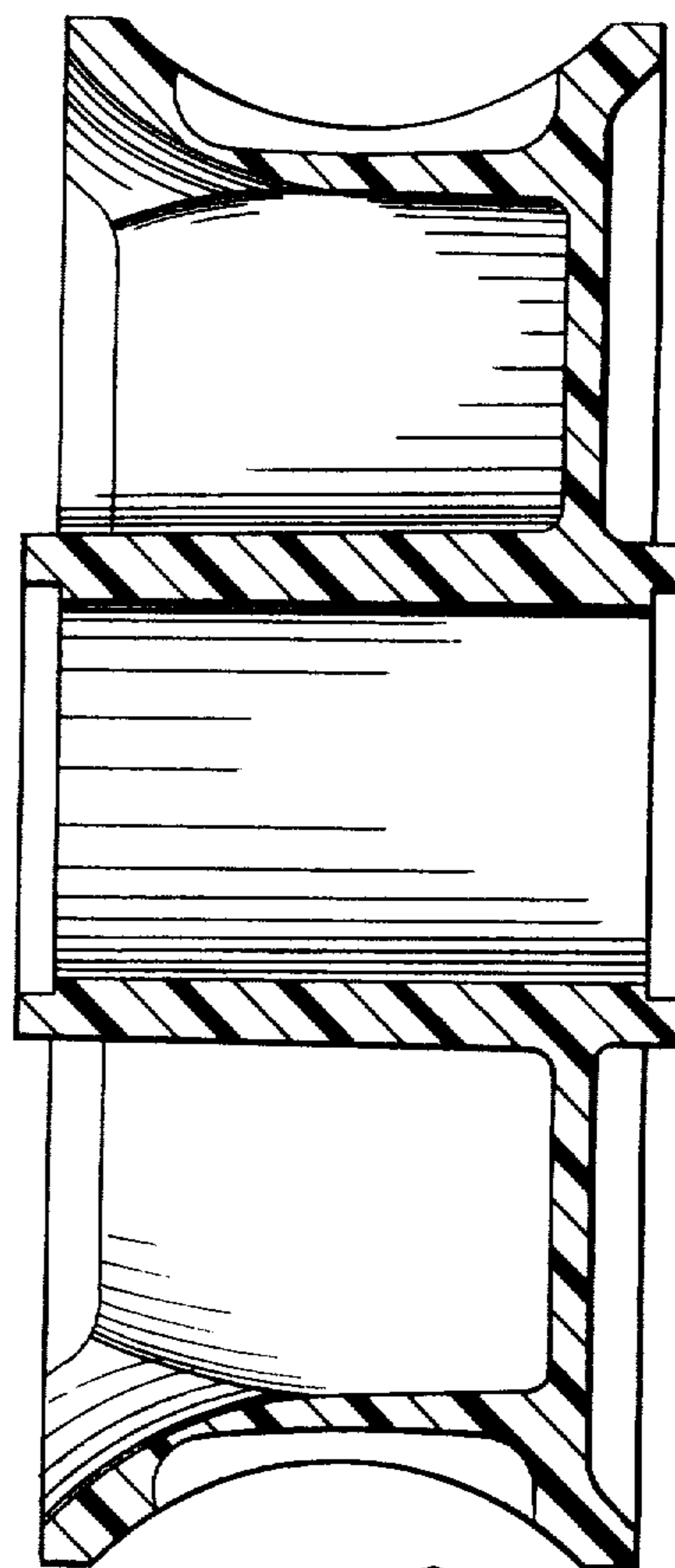

Fig. 3.

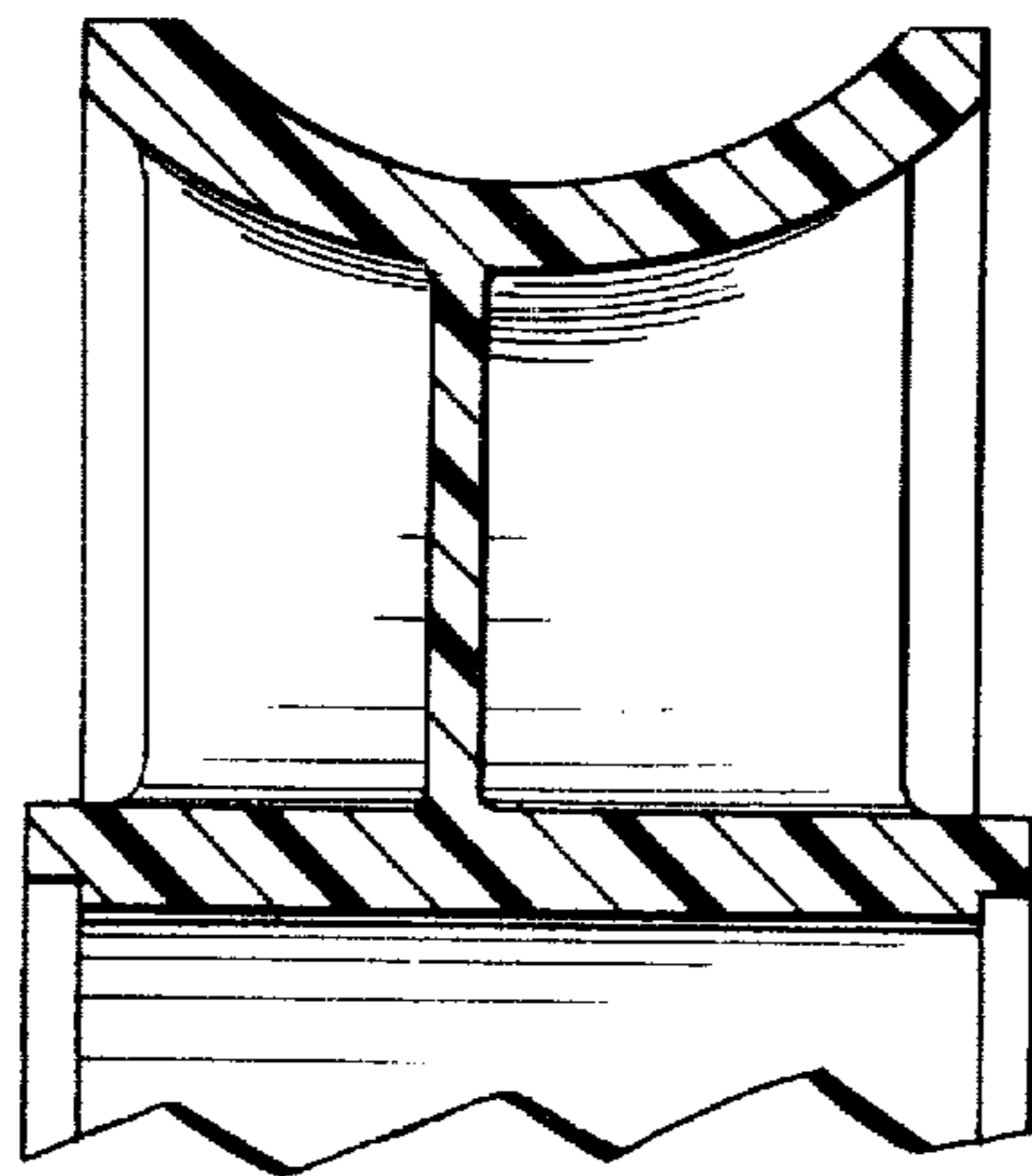

Fig. 4.

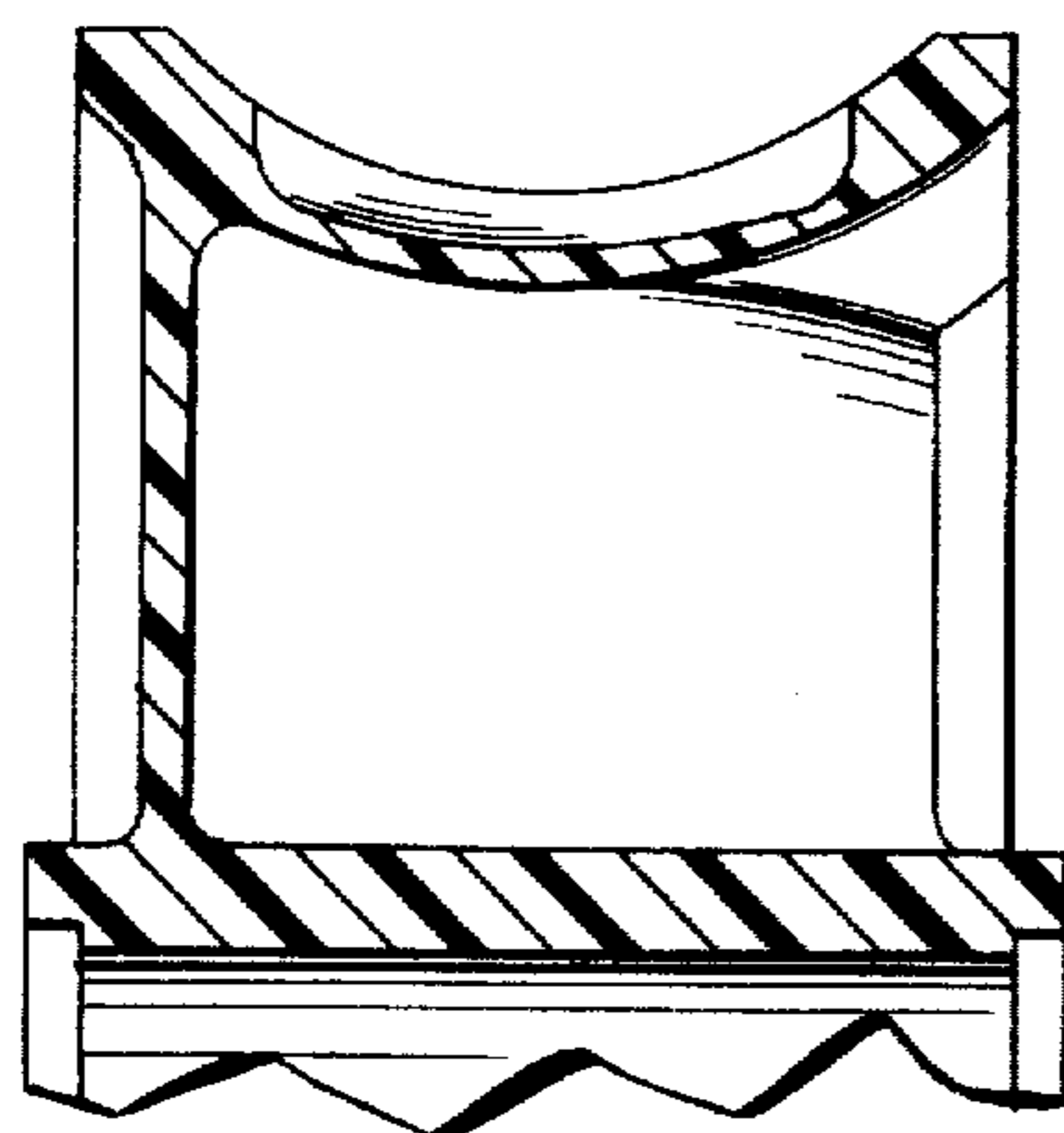

Fig. 5.