

[54] COMBINED FRONT AND REAR FENDERS, CHAIN GUARD, ENGINE COVER AND FUEL TANK FOR MOPE

[75] Inventor: Daniel G. Hahn, Olney, Ill.

[73] Assignee: AMF Incorporated, White Plains, N.Y.

[**] Term: 14 Years

[21] Appl. No.: 184,703

[22] Filed: Sep. 8, 1980

[51] Int. Cl. D12-11

[52] U.S. Cl. D12/110; D12/111

[58] Field of Search D12/110, 111; 180/219, 180/223; 280/281 R

[56] References Cited PUBLICATIONS

1980 Sachs Brochure, p. 3, Sachs Suburban, top right side of p.

American Bicyclist & Motorcyclist, 3/80, p. 47, Pacer Moped, lower left side of p.

American Bicyclist & Motorcyclist, 2/79, p. 122, Motron Corp. Moped, lower right side of p.

Primary Examiner—James M. Gandy

Attorney, Agent, or Firm—David E. Dougherty; Walter R. Pfluger

[57] CLAIM

The ornamental design for a combined front and rear fenders, chain guard, engine cover and fuel tank for a moped, as shown and described.

DESCRIPTION

FIG. 1 is a perspective view of the combined front and rear fenders, chain guard, engine cover and fuel tank for a moped showing my new design, the broken lines being for illustrative purposes only;

FIG. 2 is a top plan view thereof;

FIG. 3 is a side elevational view thereof opposite to that shown in FIG. 1;

FIG. 4 is a front elevational view thereof;

FIG. 5 is a rear elevational view thereof; and

FIG. 6 is a bottom plan view thereof.

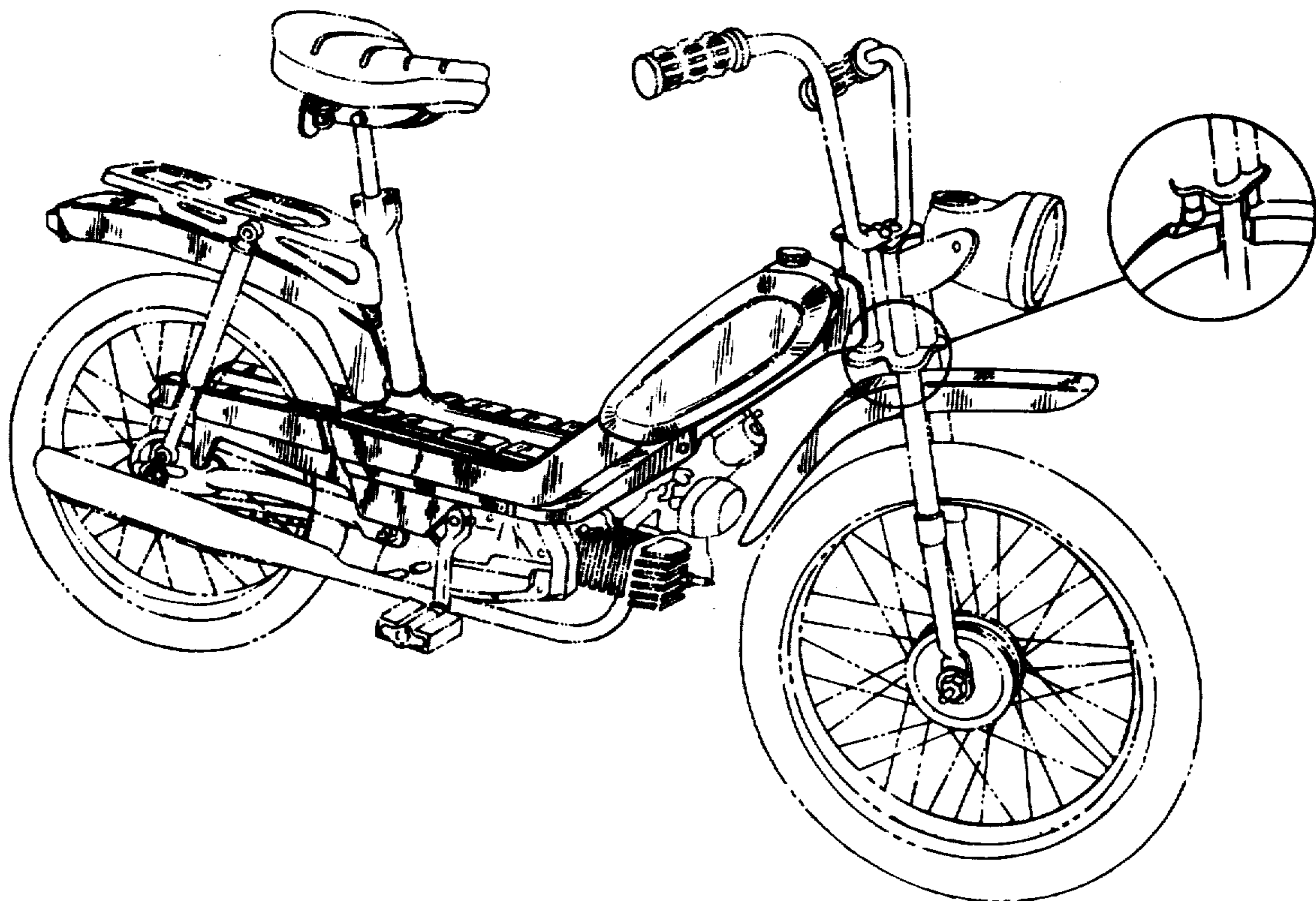

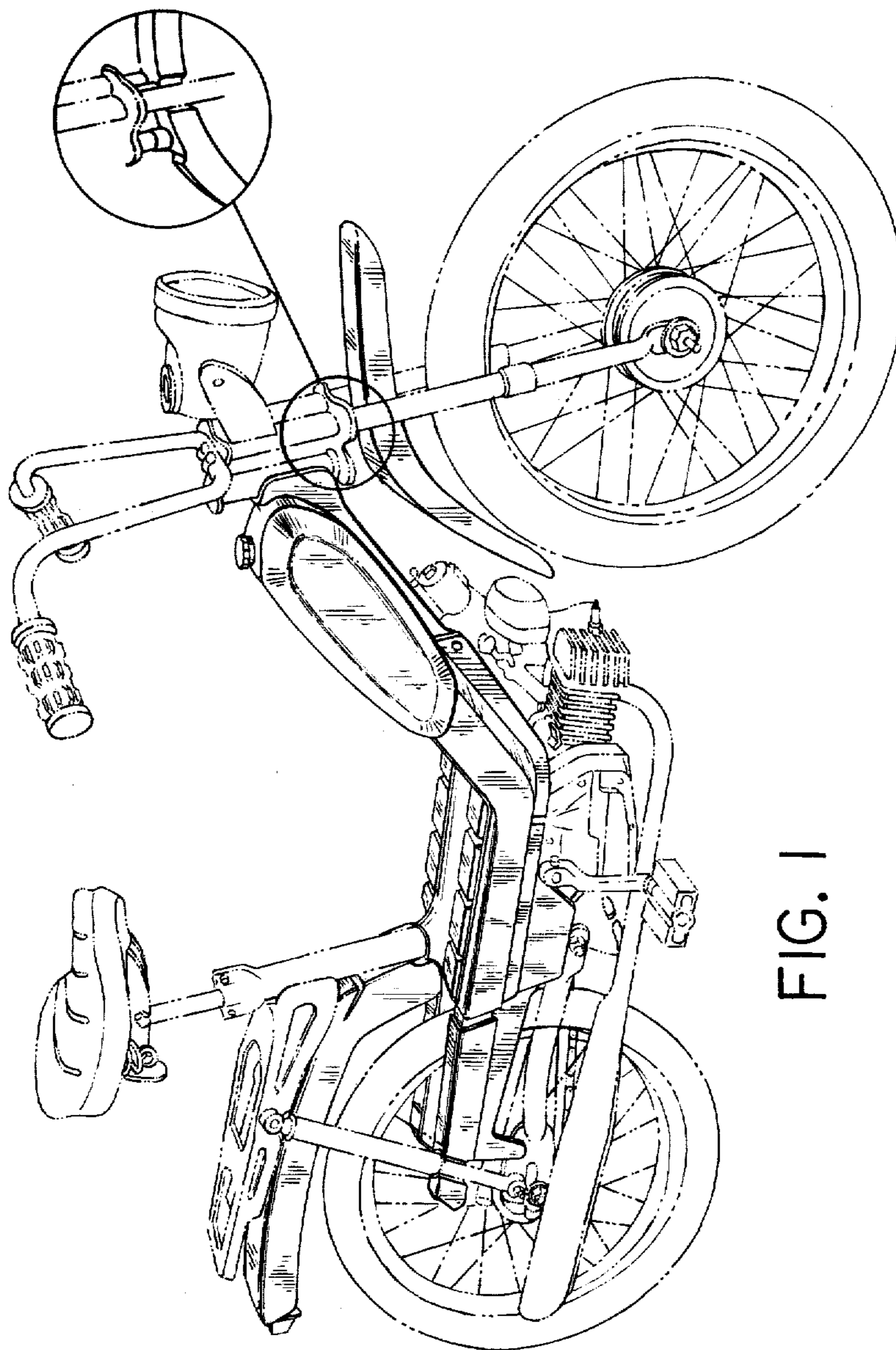

FIG. 1

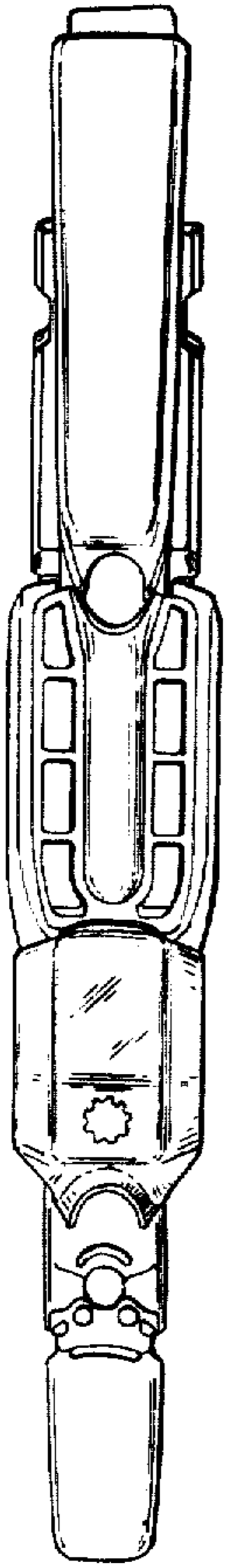

FIG. 2

FIG. 4

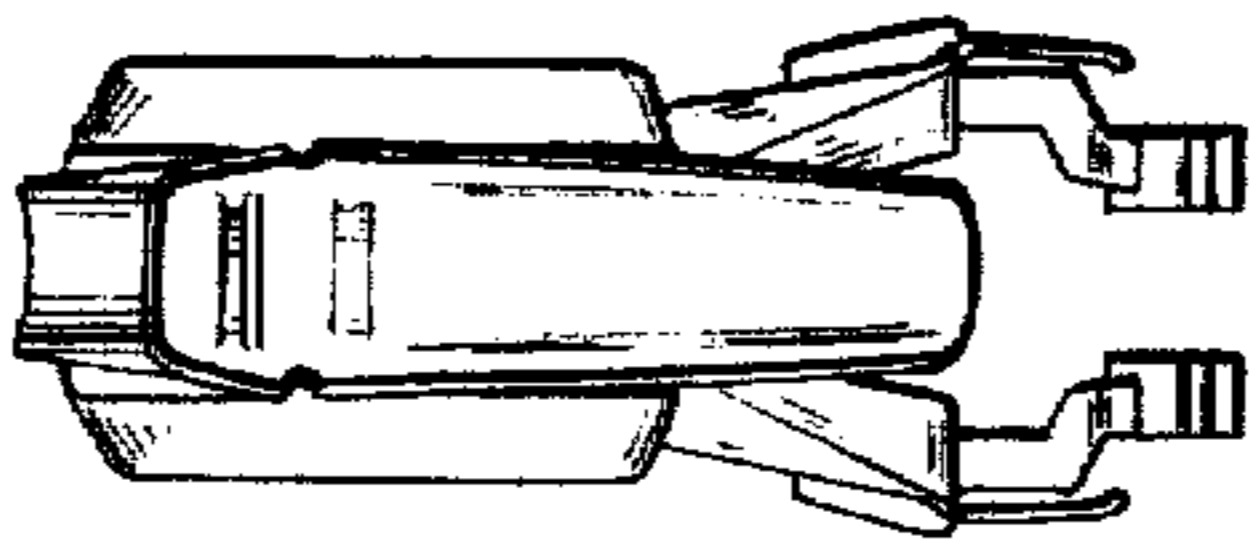

FIG. 3

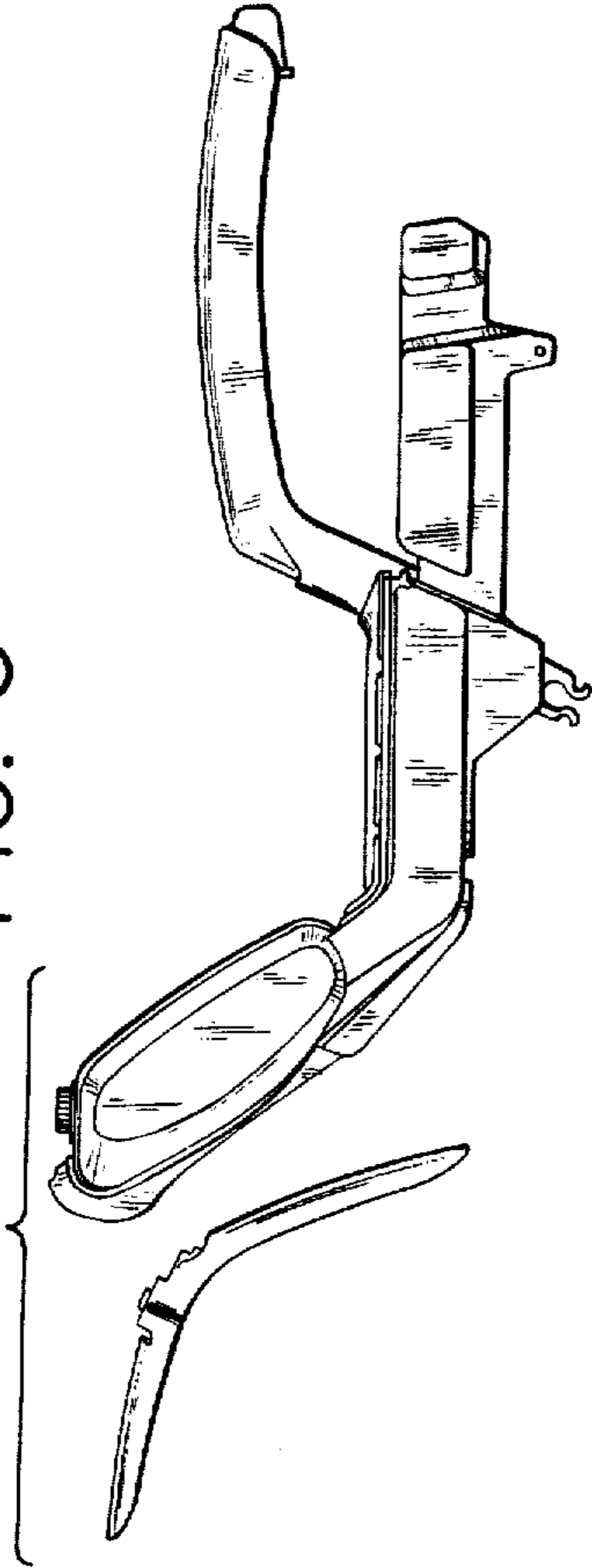

FIG. 5

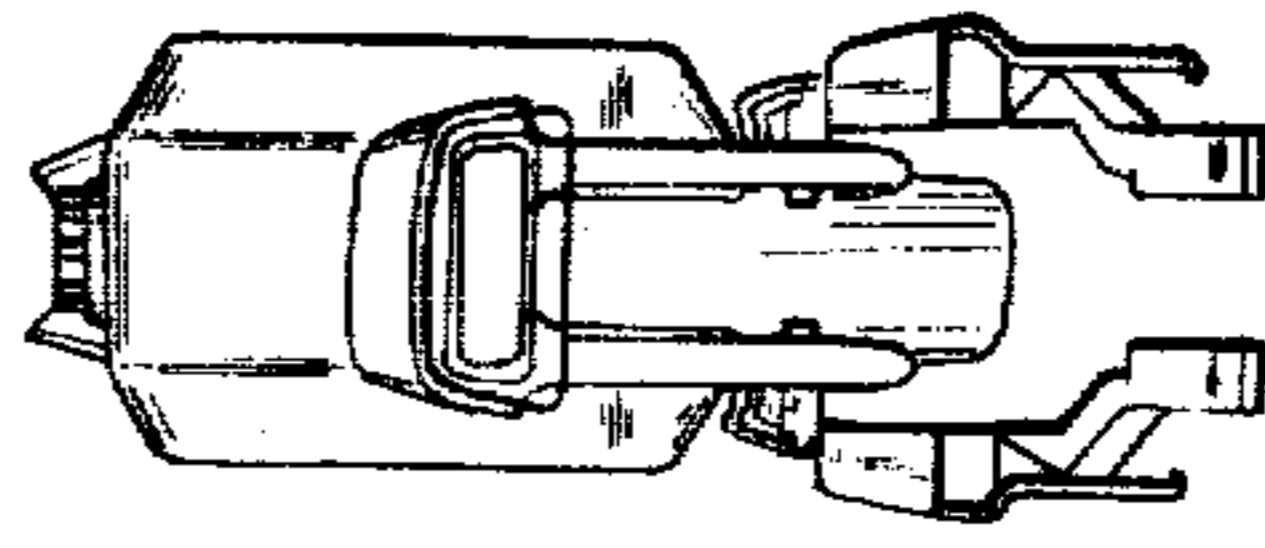

FIG. 6

