

[54] **BOOT HOLDER**

[76] Inventors: **Jorgen Larsen**, 4772 - 238 St., Langley, British Columbia, Canada, V3A 4P1; **Thor Heske**, 24095 - 25 Ave., Aldergrove, British Columbia, Canada, V0X 1A0

[\*\*] Term: **14 Years**

[21] Appl. No.: **235,108**

[22] Filed: **Feb. 17, 1981**

[51] Int. Cl. .... **D6-06**

[52] U.S. Cl. .... **D6/116; D6/125**

[58] Field of Search ..... **D6/114, 116, 125, 13, D6/34; 211/35, 87, 89, 106, 119, 181, 60 R; 248/215, 309 R, 311.2, 312**

[56] **References Cited**

**U.S. PATENT DOCUMENTS**

- D. 250,077 10/1978 Urbach ..... D6/116
- 940,812 11/1909 Hermann ..... 211/34
- 1,813,573 7/1931 Huestis ..... 211/35

- 2,267,634 12/1941 Arenz ..... 211/34
- 2,284,552 5/1942 Arenz ..... 211/35
- 2,902,167 9/1959 Smith ..... 211/34

*Primary Examiner*—B. J. Bullock  
*Attorney, Agent, or Firm*—Carver & Co.

[57] **CLAIM**

The ornamental design for a boot holder, substantially as shown and described.

**DESCRIPTION**

FIG. 1 is a reduced perspective view of a boot holder showing our new design, the portion of a horizontal bar being shown in broken lines for illustrative purposes only;

FIG. 2 is a top plan view thereof;

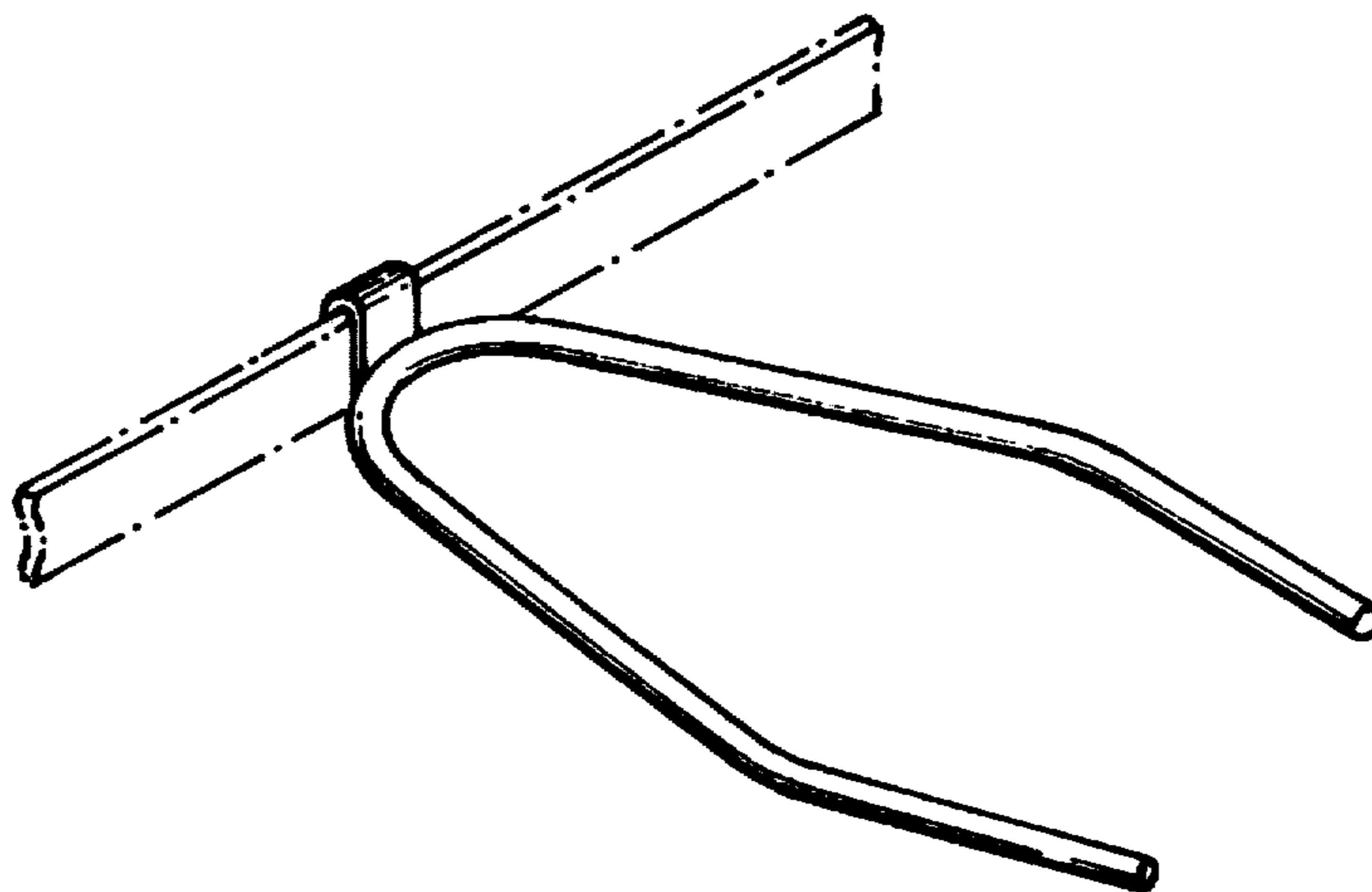
FIG. 3 is a bottom plan view thereof;

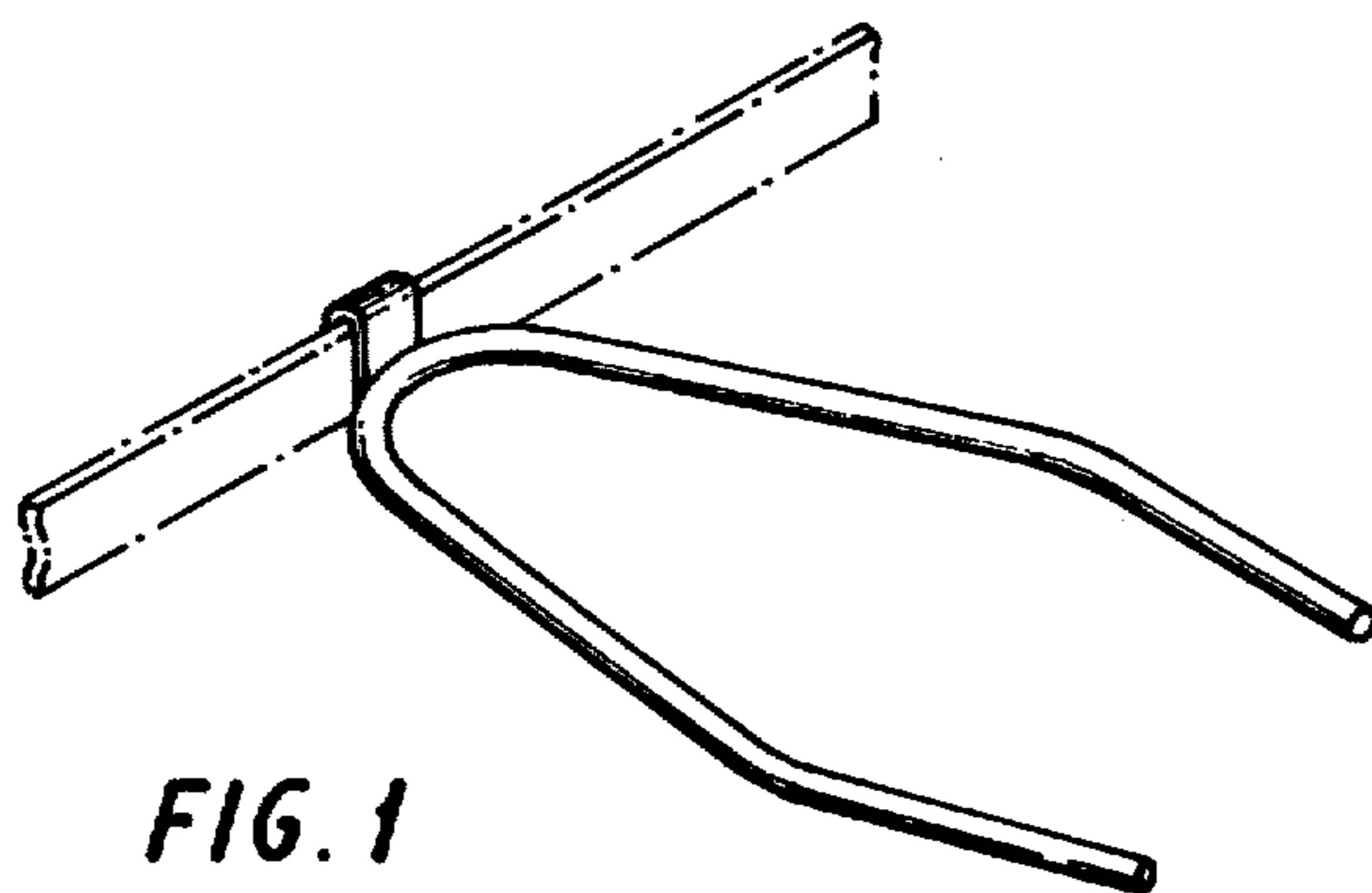
FIG. 4 is a side elevational view taken from the left of FIG. 1;

FIG. 5 is a side elevational view taken from the right of FIG. 1;

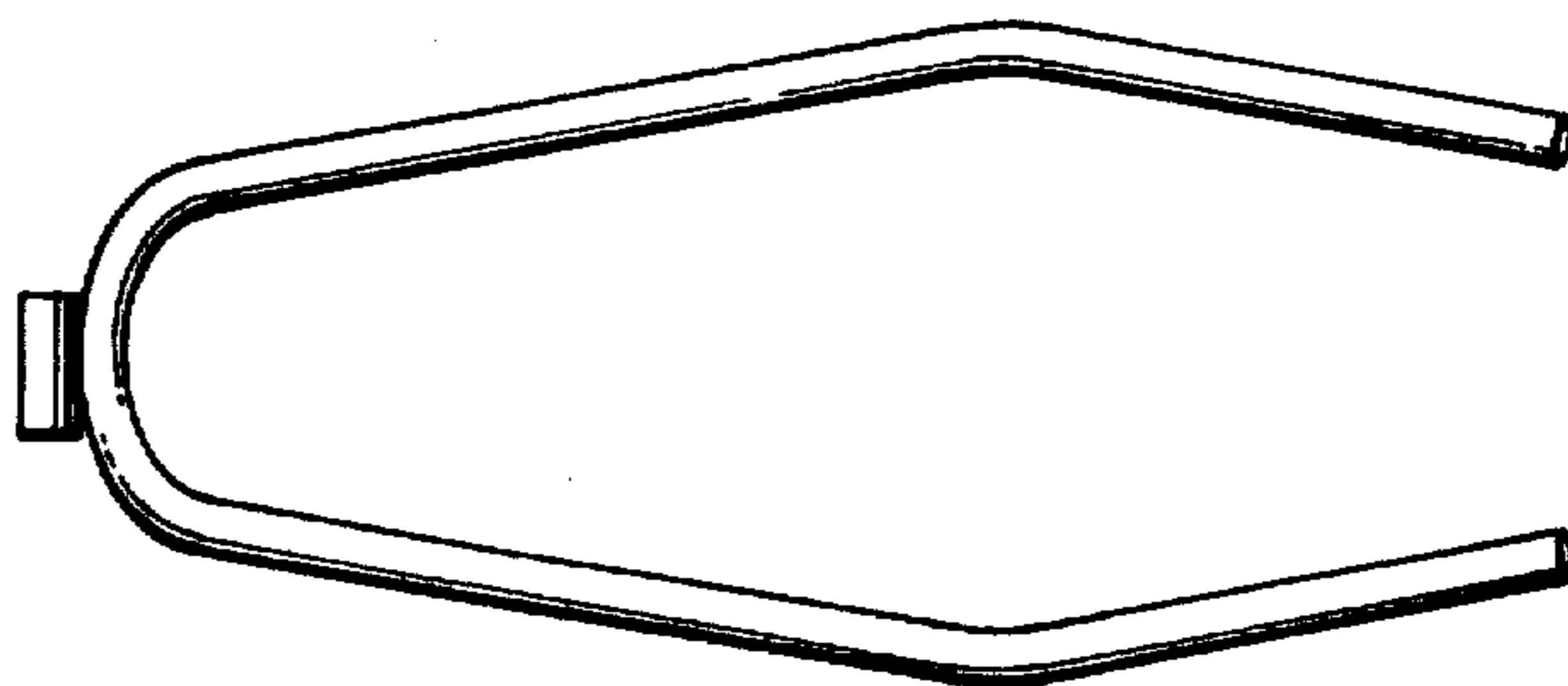
FIG. 6 is a rear elevational view thereof;

FIG. 7 is a front elevational view thereof.

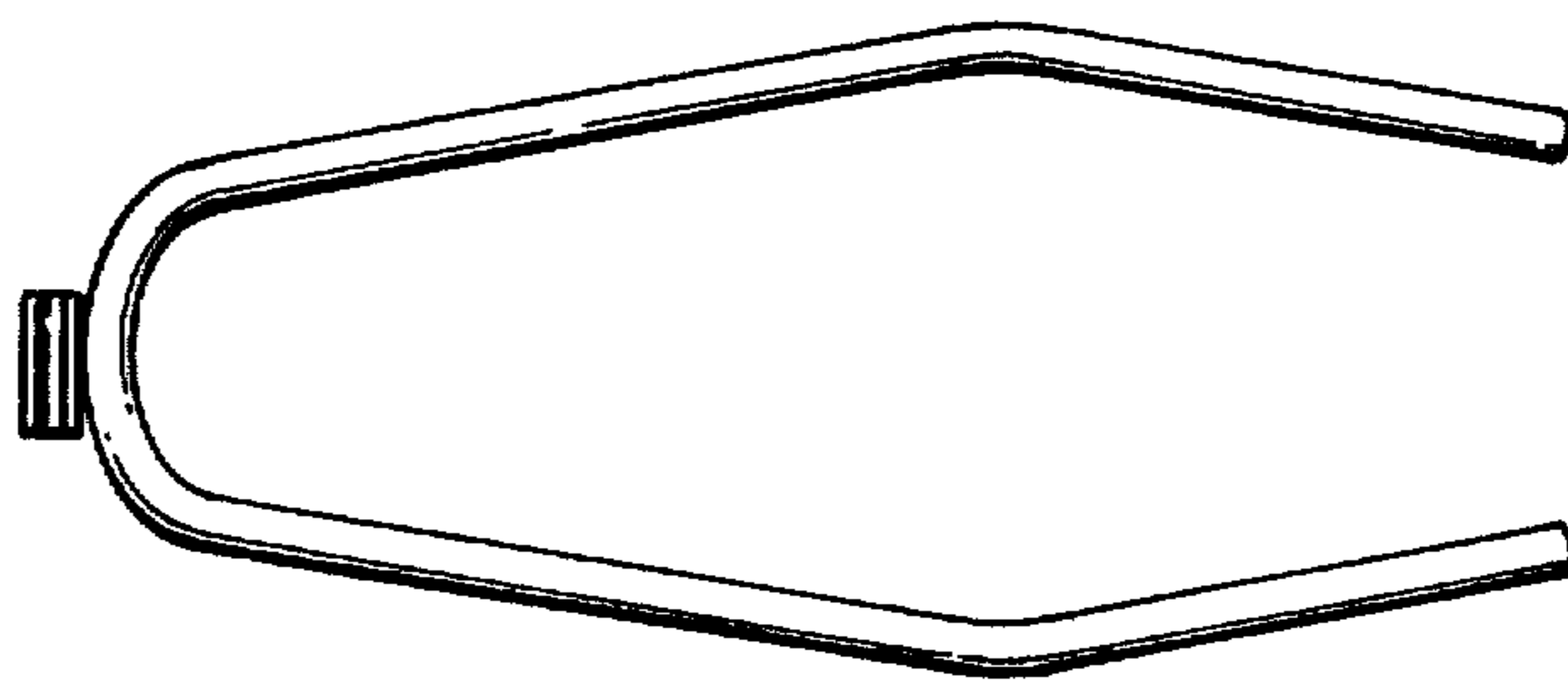




*FIG. 1*



*FIG. 2*



*FIG. 3*

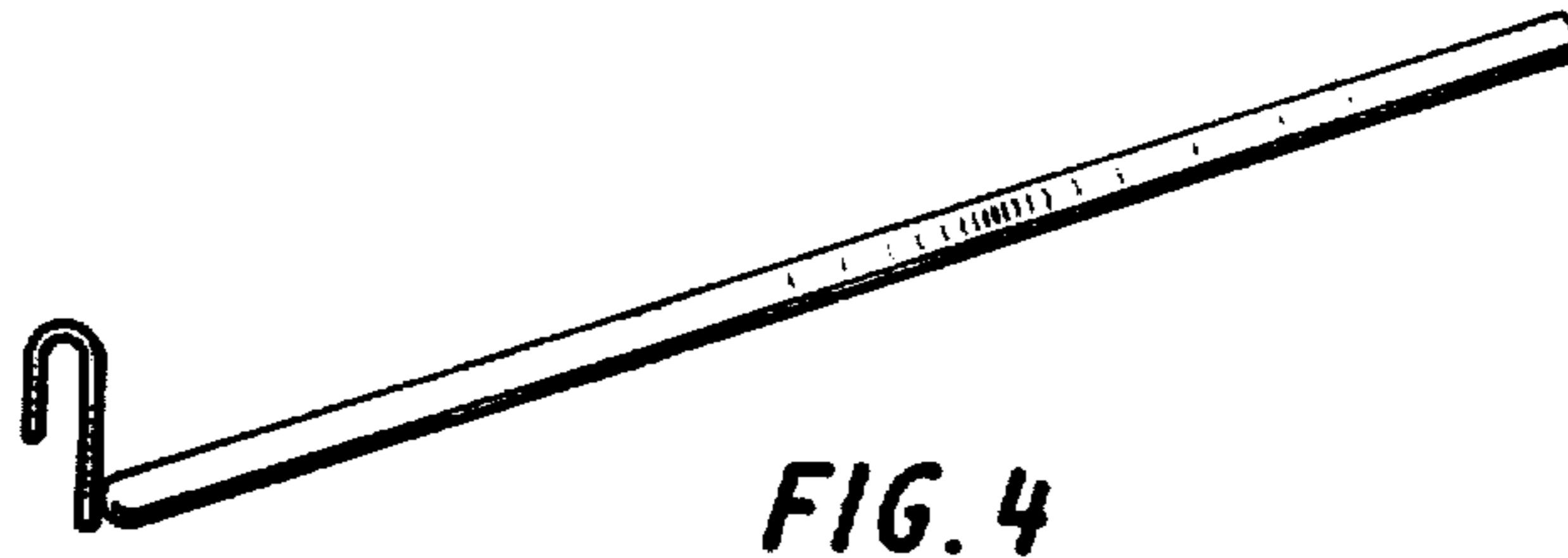


FIG. 4

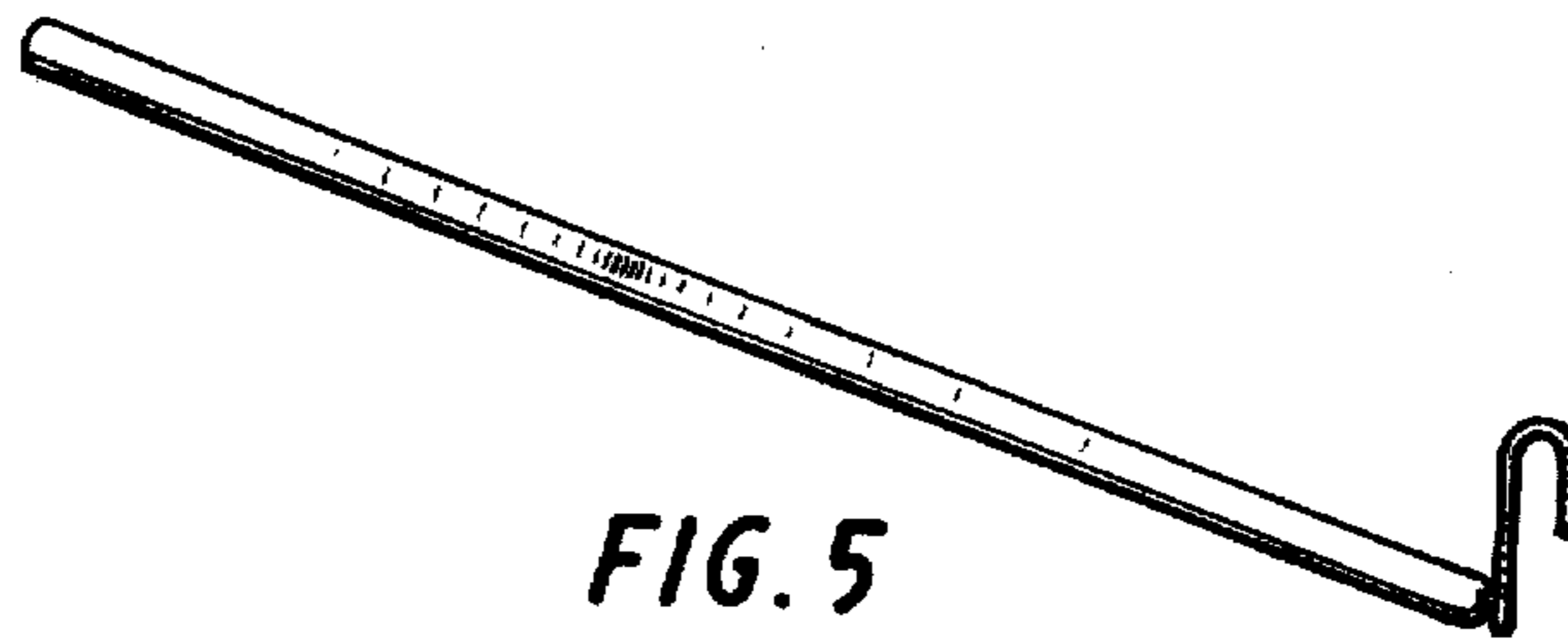


FIG. 5

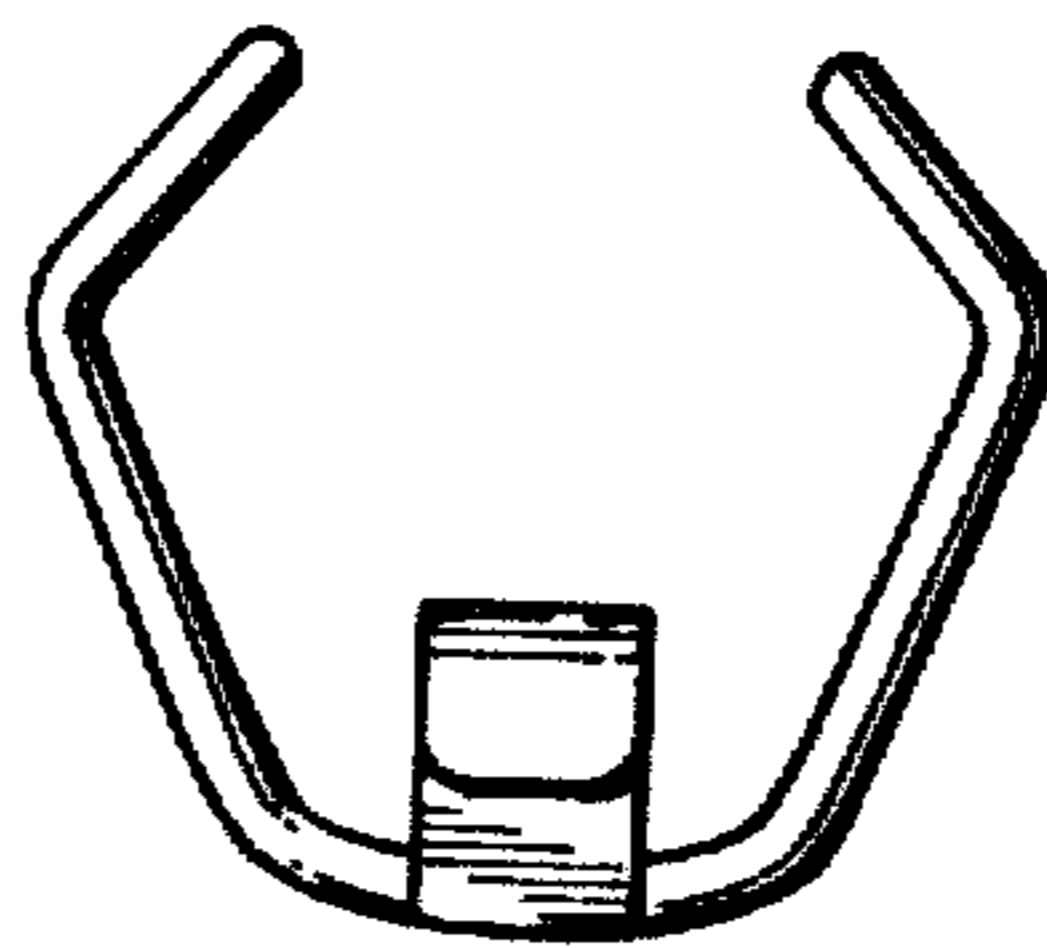


FIG. 6

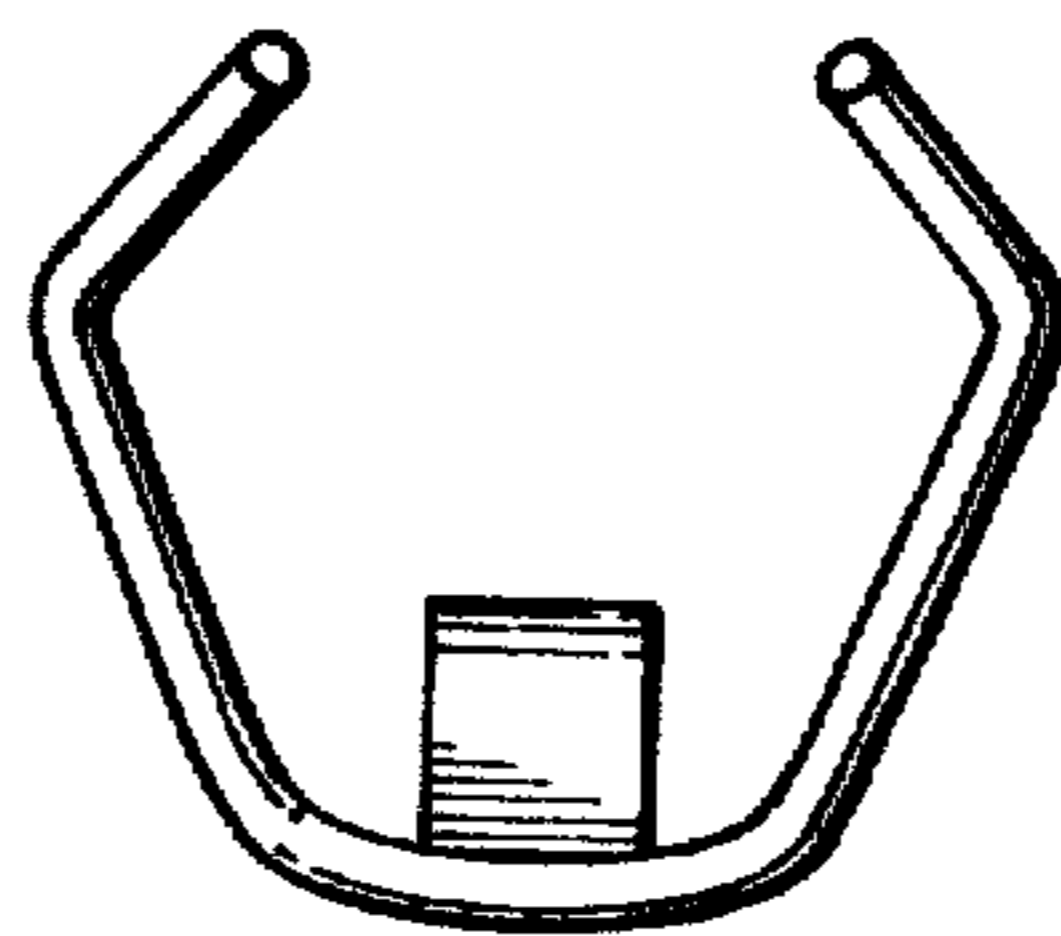


FIG. 7