

[54] RAILWAY CAR MOVING VEHICLE

[75] Inventor: Tapio M. Rannanmaki, Espoo, Finland

[73] Assignee: Vaino Tapio Saalasti, Helsinki, Finland

[**] Term: 14 Years

[21] Appl. No.: 65,966

[22] Filed: Aug. 13, 1979

[51] Int. Cl. D12-03

[52] U.S. Cl. D12/36; D15/23

[58] Field of Search D12/36, 39; D15/23; 105/215 C

[56] References Cited

U.S. PATENT DOCUMENTS

3,738,285 6/1973 Olson, Sr. et al. D12/39

OTHER PUBLICATIONS

The New Heavy-Duty Trackmobile, Whiting Bulletin T-115, Trackmobile on front cover.

Primary Examiner—James M. Gandy
Attorney, Agent, or Firm—Browdy & Neimark

[57] CLAIM

The ornamental design for a railway car moving vehicle, substantially as shown and described.

DESCRIPTION

FIG. 1 is a side elevational view of a railway car moving vehicle showing my new design in its track engaging condition;

FIG. 2 is a rear elevational view thereof;

FIG. 3 is a front elevational view thereof;

FIG. 4 is a side elevational view thereof in its terrain engaging condition; and

FIG. 5 is a top plan view of FIG. 1.

The side opposite to that shown in FIGS. 1 and 5 is a mirror image thereof.

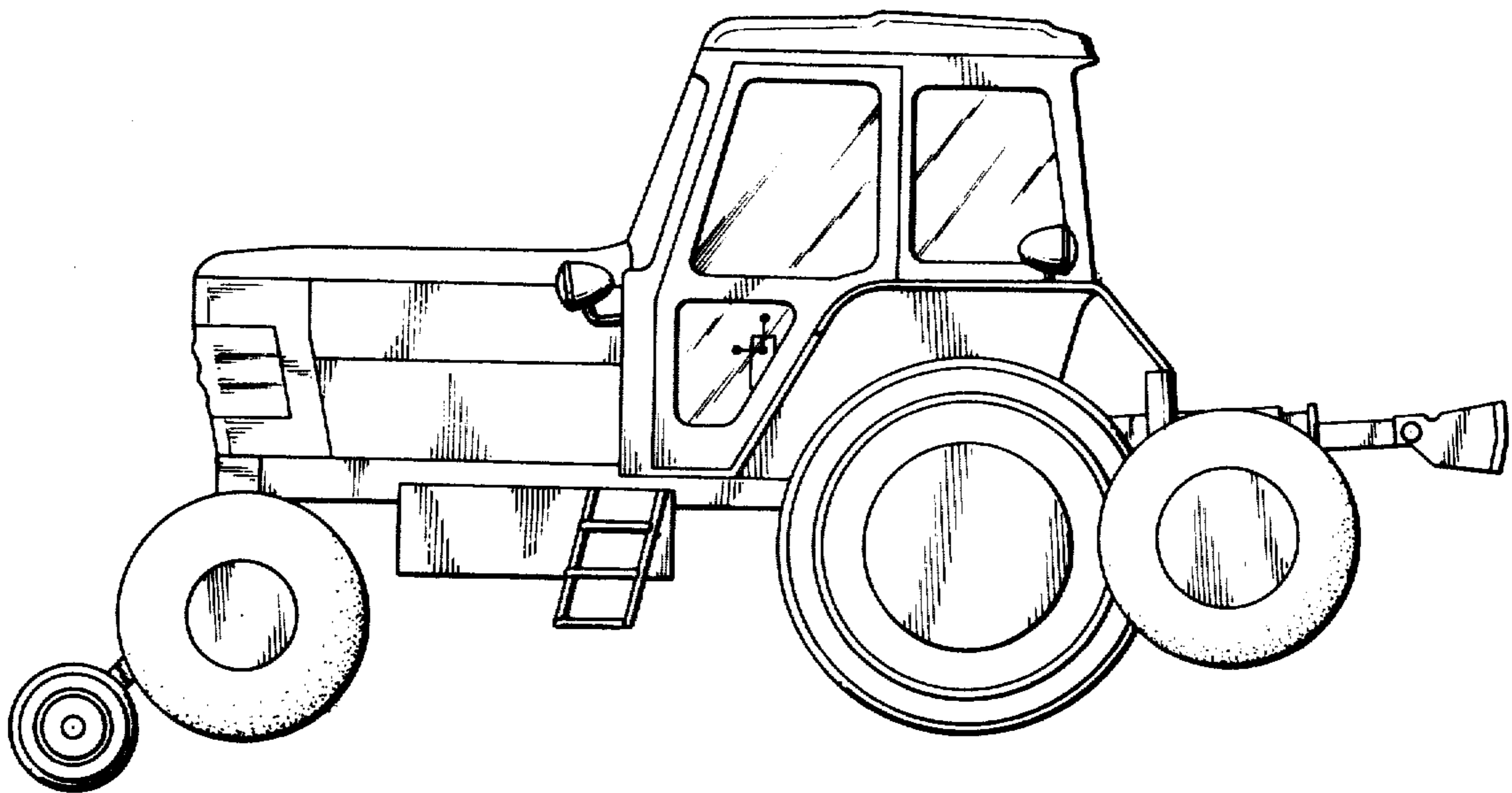

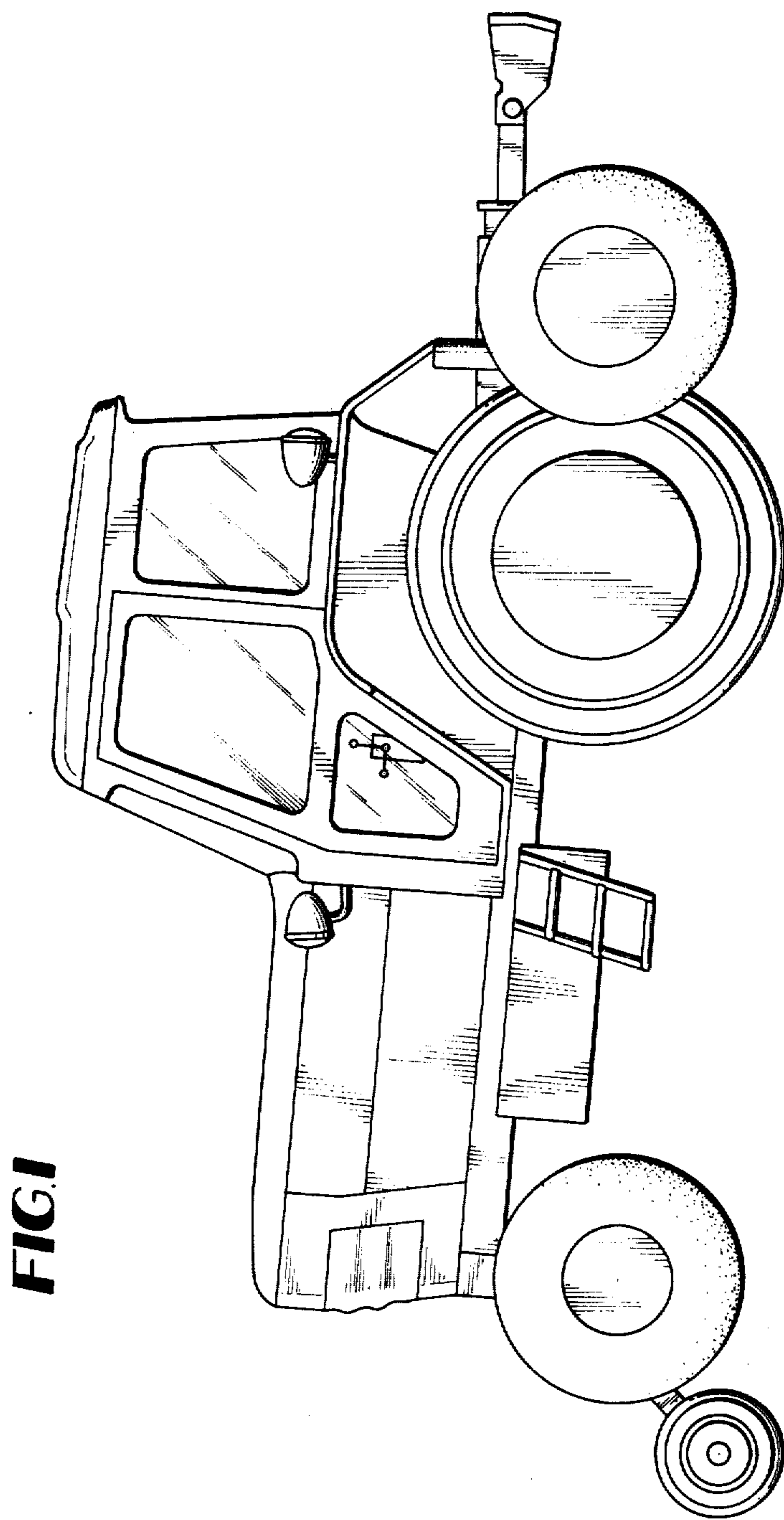

FIG. 1

FIG.3

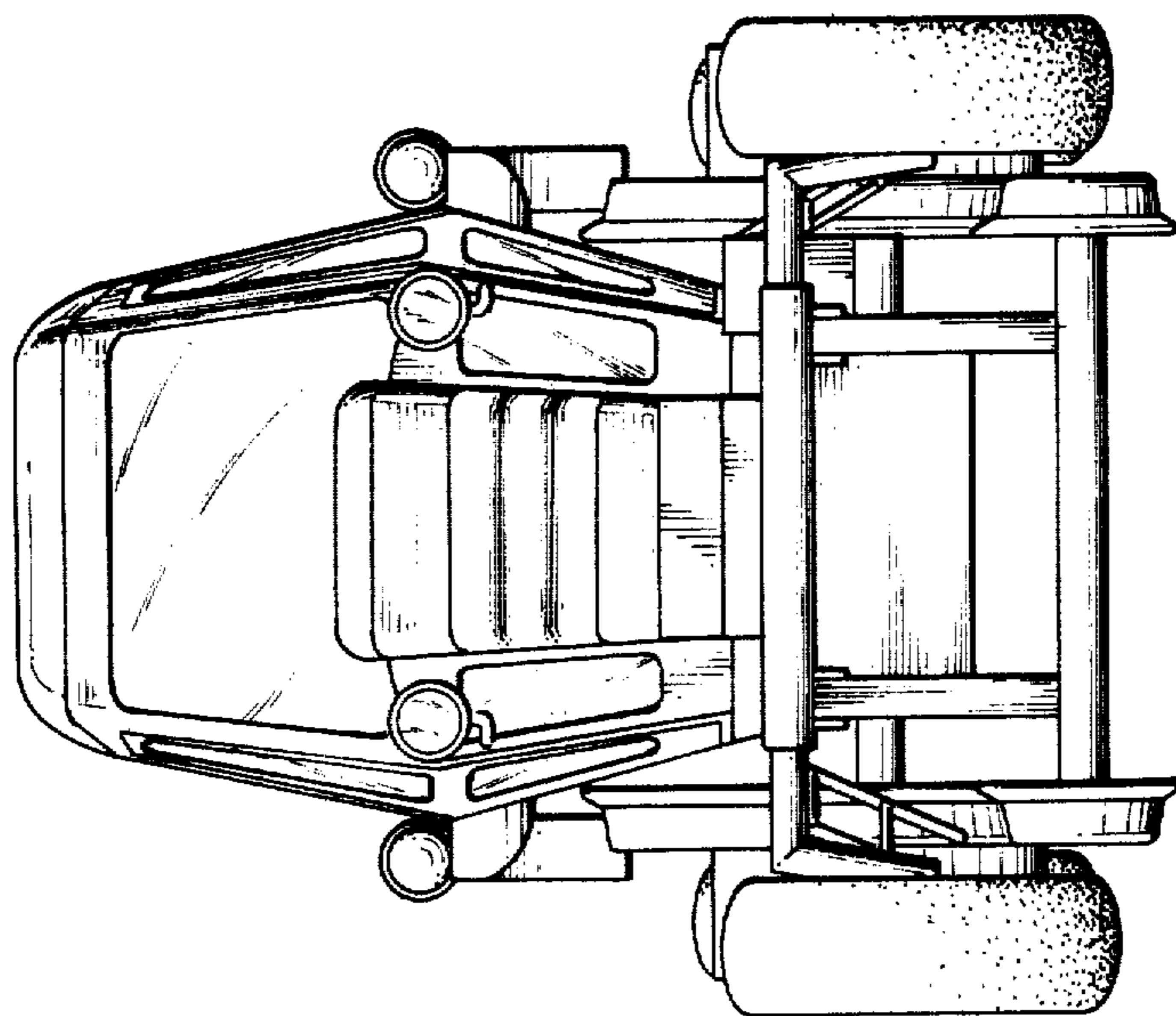
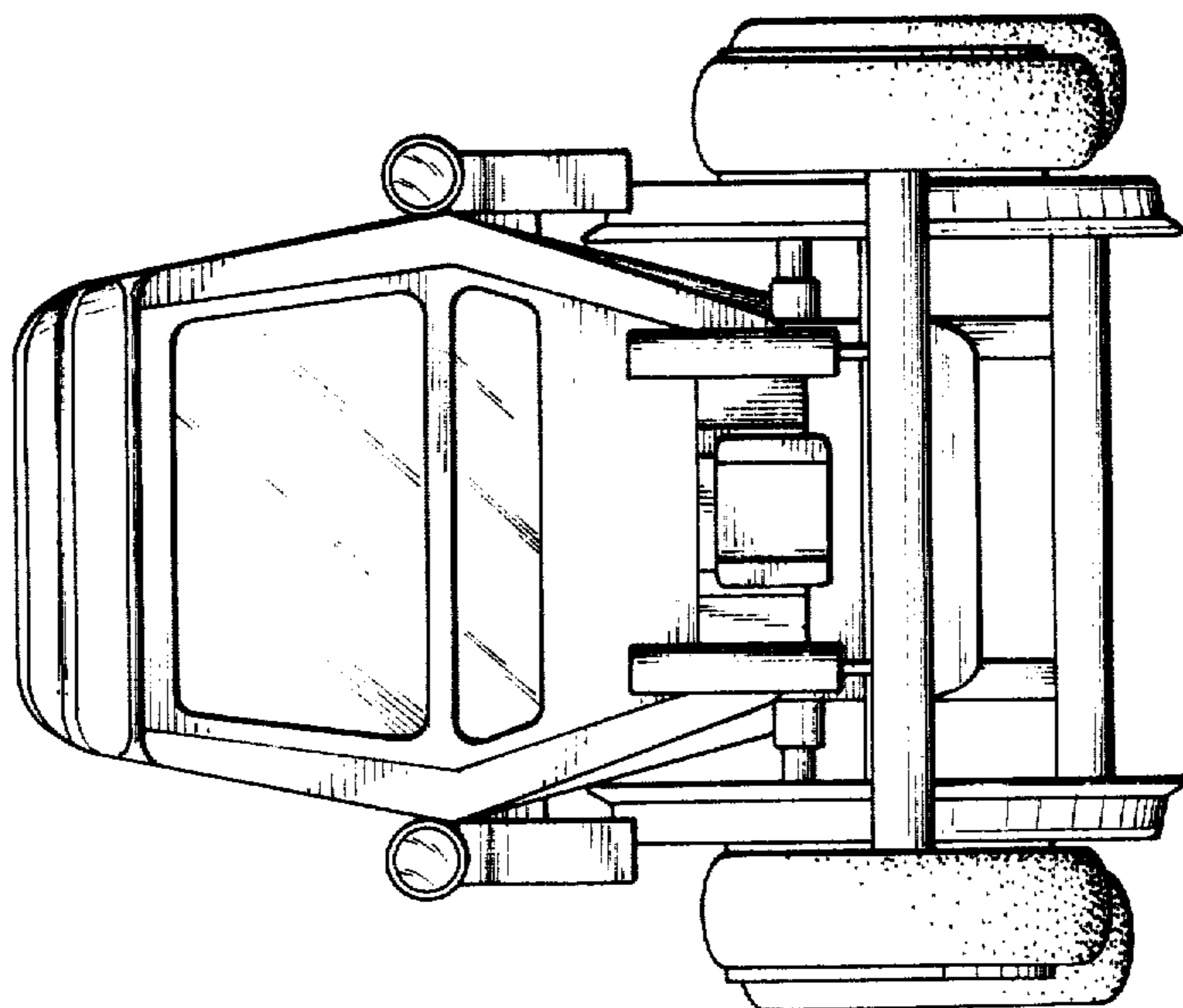

FIG.2



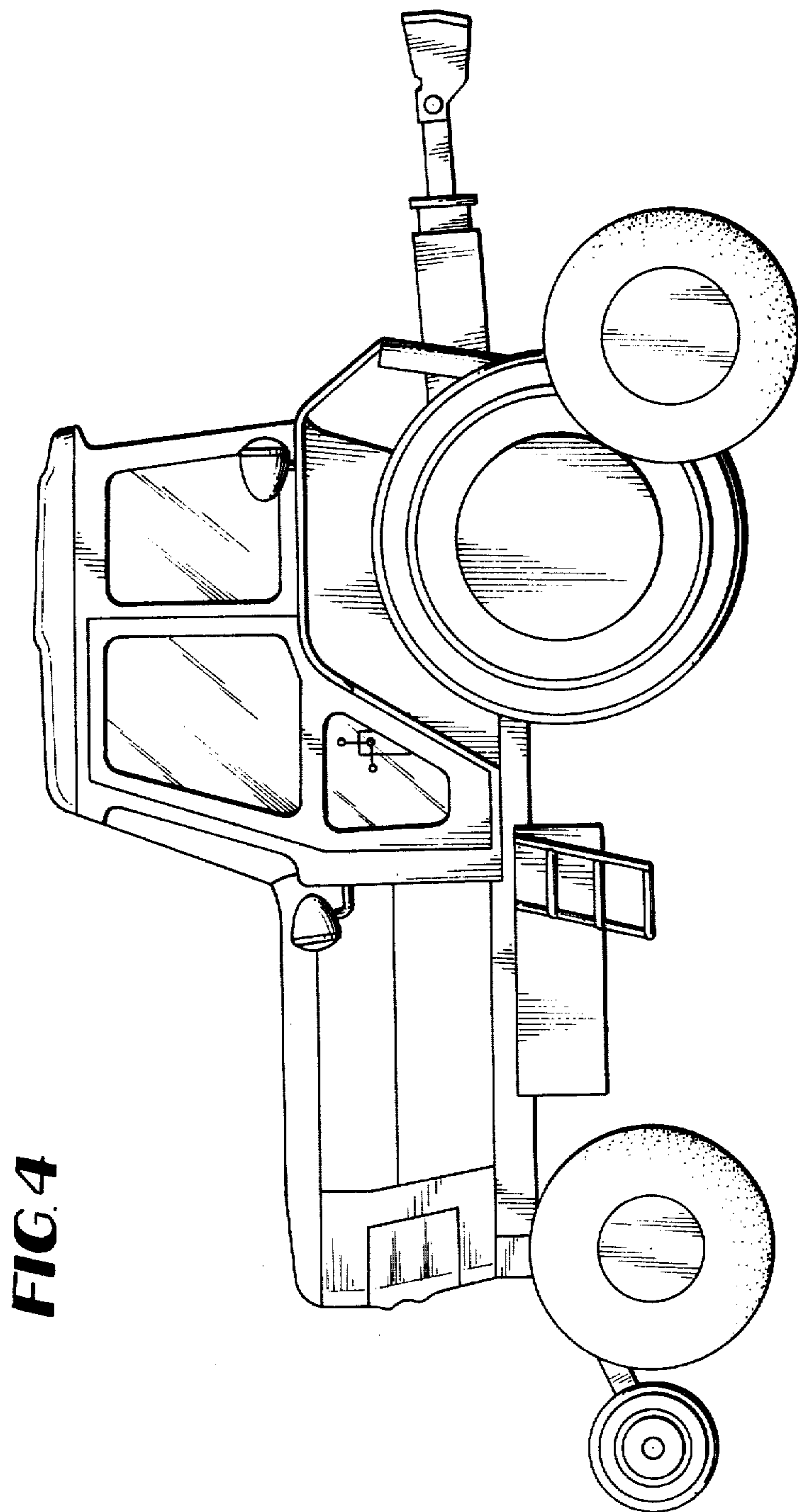

FIG. 5

