

[54] MOTORCYCLE

53-473816 4/1978 Japan .

[75] Inventors: Hitoshi Ikeda, Tokorozawa; Masahiro Satoh, Asaka; Koichi Arima, Wako, all of Japan

[73] Assignee: Honda Giken Kogyo Kabushiki Kaisha, Honda Motor Co., Ltd., Tokyo, Japan

[**] Term: 14 Years

[21] Appl. No.: 195,640

[22] Filed: Oct. 9, 1980

[30] Foreign Application Priority Data

Apr. 24, 1980 [JP] Japan 55-16515

[51] Int. Cl. D12-11

[52] U.S. Cl. D12/110

[58] Field of Search D12/110; 180/219, 223

[56] References Cited

FOREIGN PATENT DOCUMENTS

45-312675 10/1970 Japan .

OTHER PUBLICATIONS

Motorcyclist, 1/1/69, pp. 24 & 25, Motorcycle.

Stile Industria, 2/62, p. 19, Motorcycle.

Motorcyclist, 10/79, p. 82, Yamaha Passol DS50D & Passola SA50.

Primary Examiner—James M. Gandy

Attorney, Agent, or Firm—Armstrong, Nikaido, Marmelstein & Kubovcik

[57] CLAIM

The ornamental design for a motorcycle, as shown.

DESCRIPTION

FIG. 1 is a right side elevational view of a motorcycle, showing our new design;

FIG. 2 is a left side elevational view thereof;

FIG. 3 is a front elevational view thereof;

FIG. 4 is a rear elevational view thereof;

FIG. 5 is a bottom plan view thereof;

FIG. 6 is a top plan view thereof;

FIG. 7 is a front perspective view thereof; and

FIG. 8 is a rear perspective view thereof.

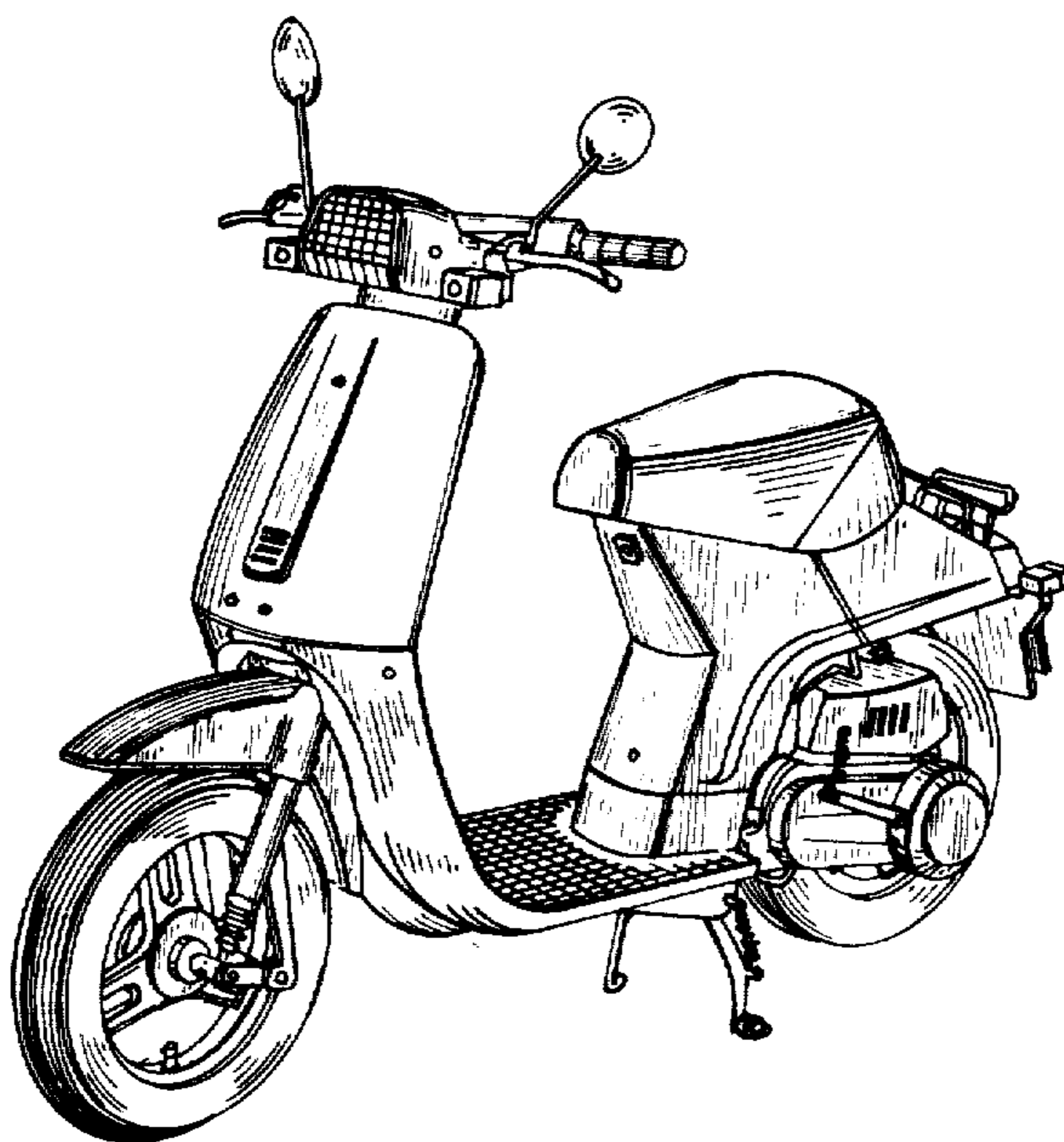

FIG. 1

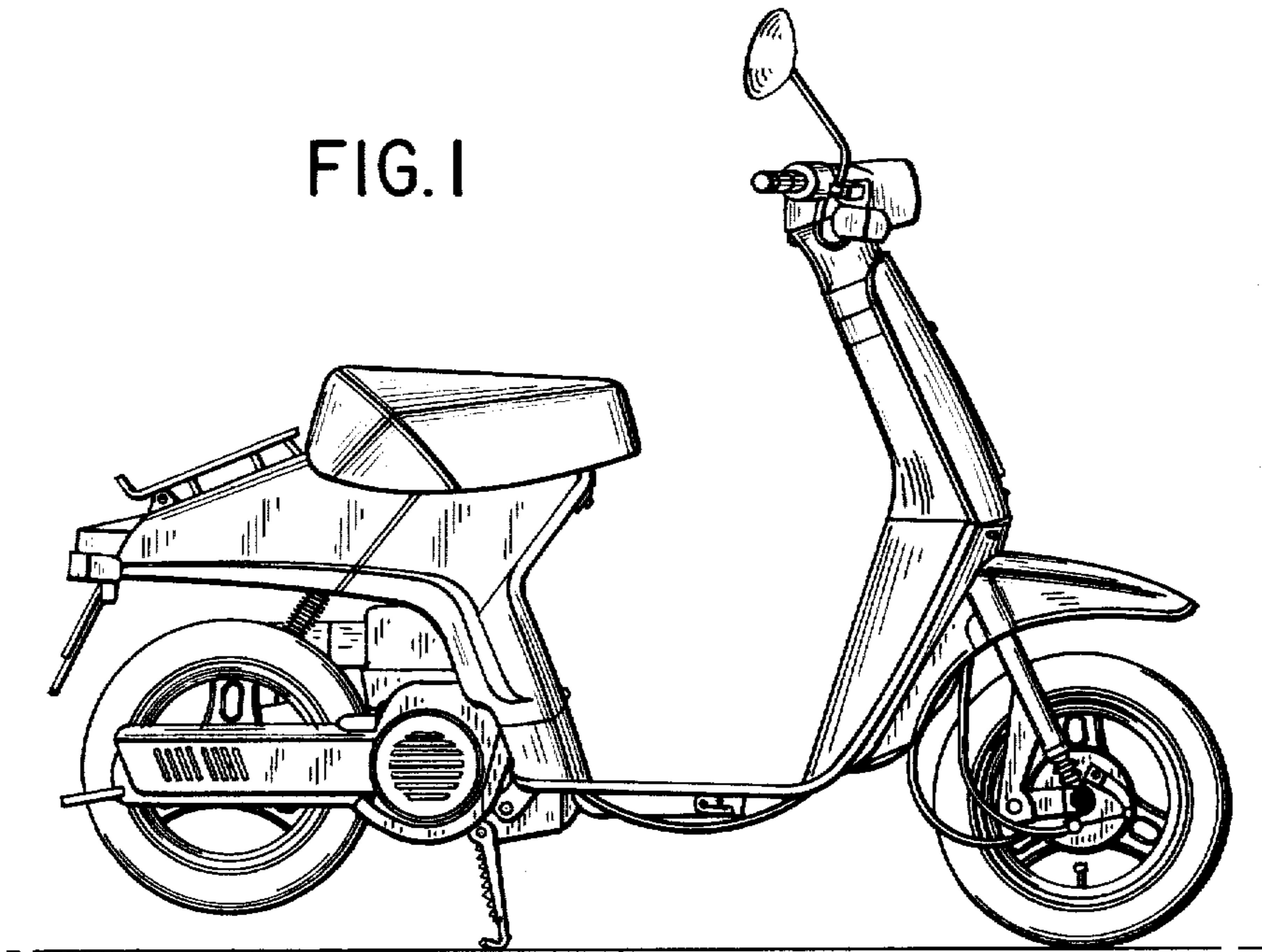

FIG. 2

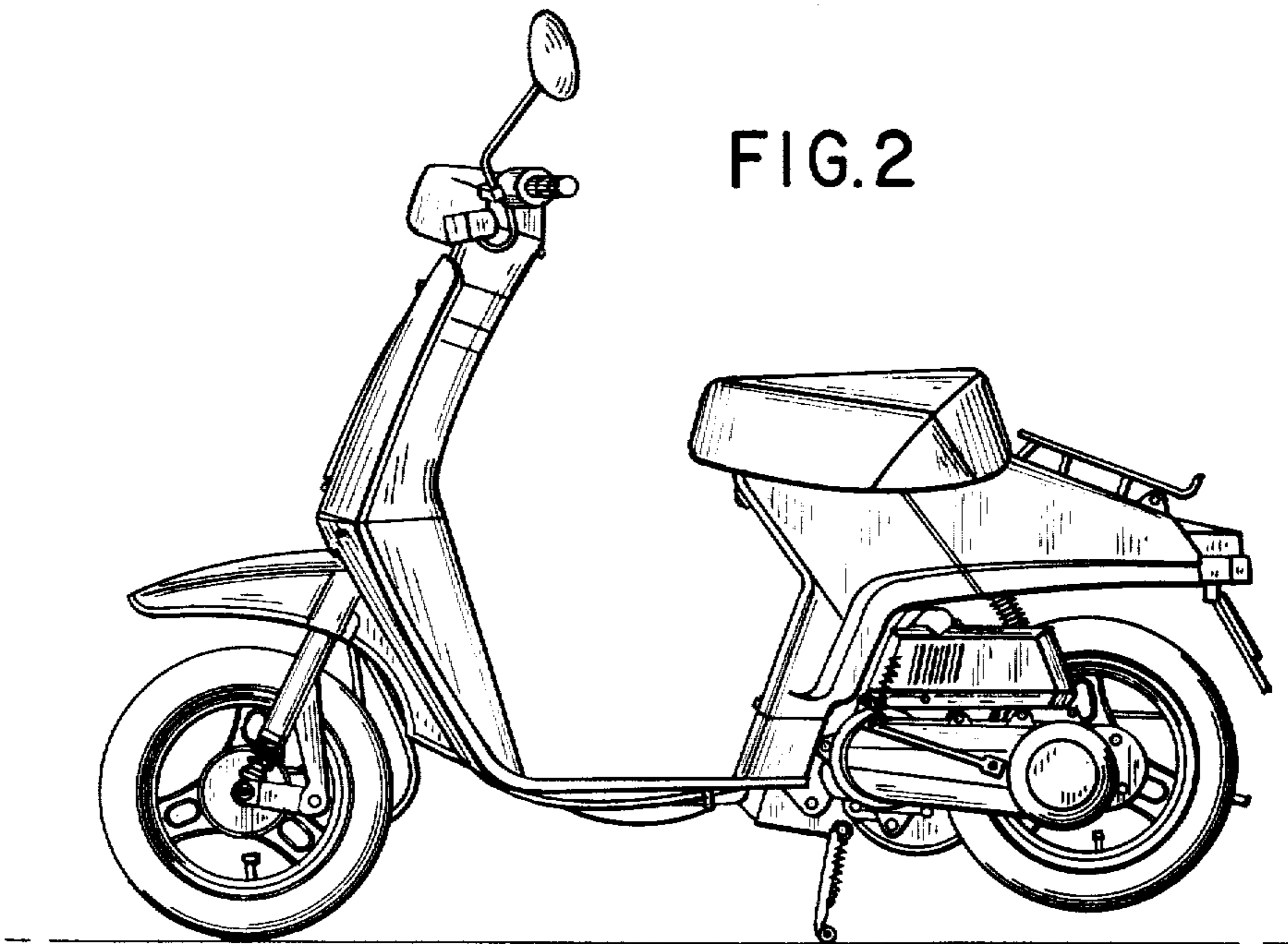

FIG.3

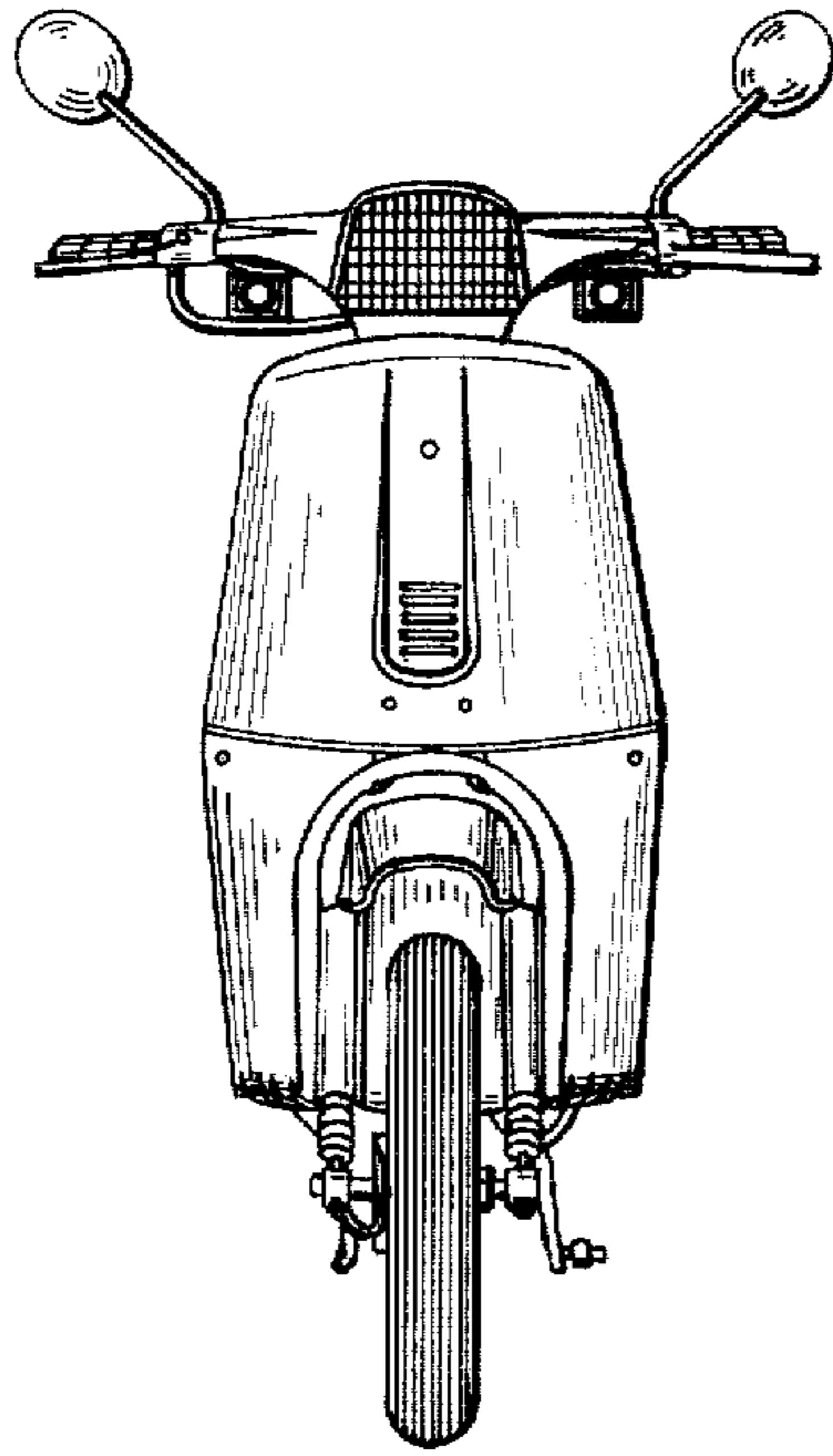

FIG.4

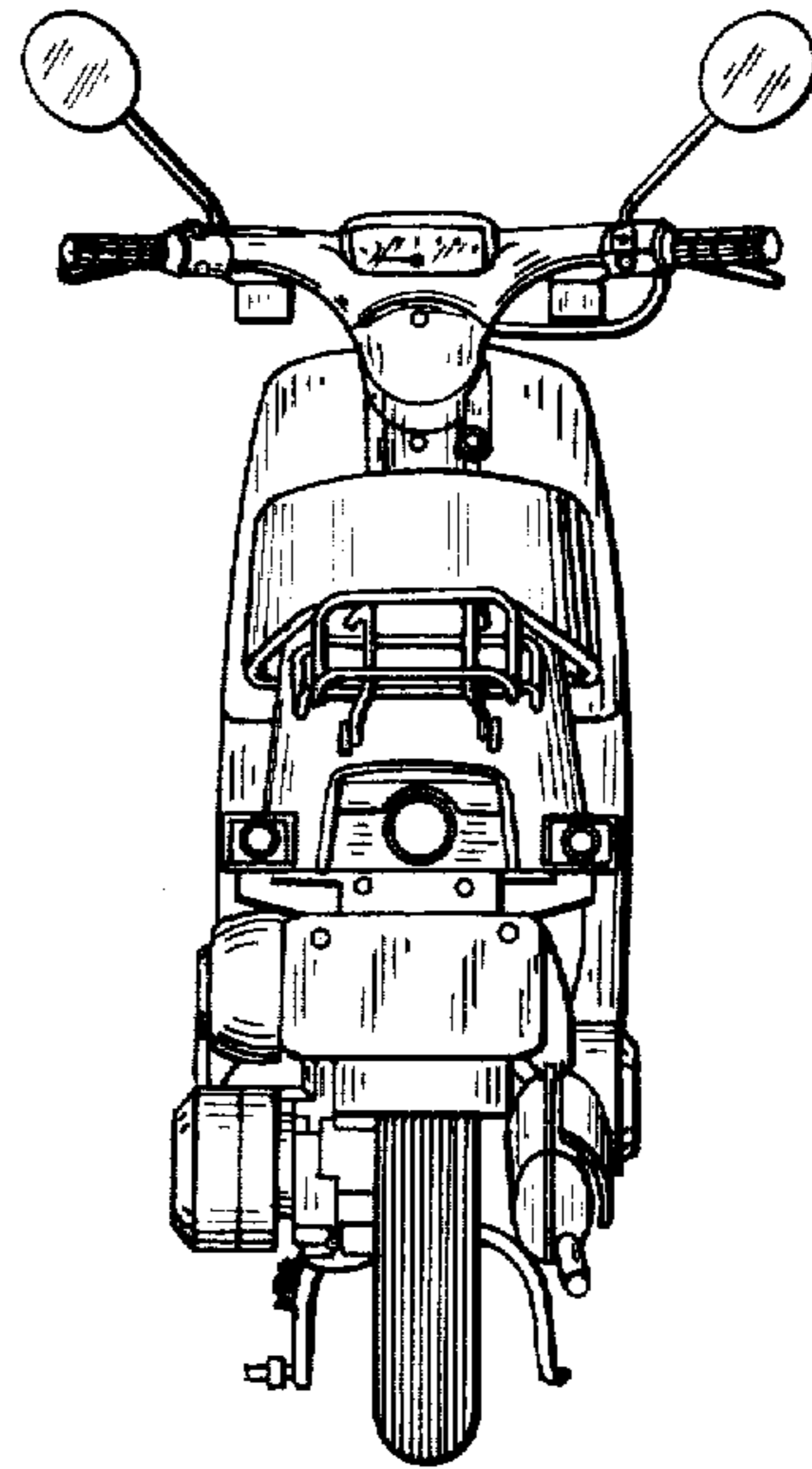

FIG.5

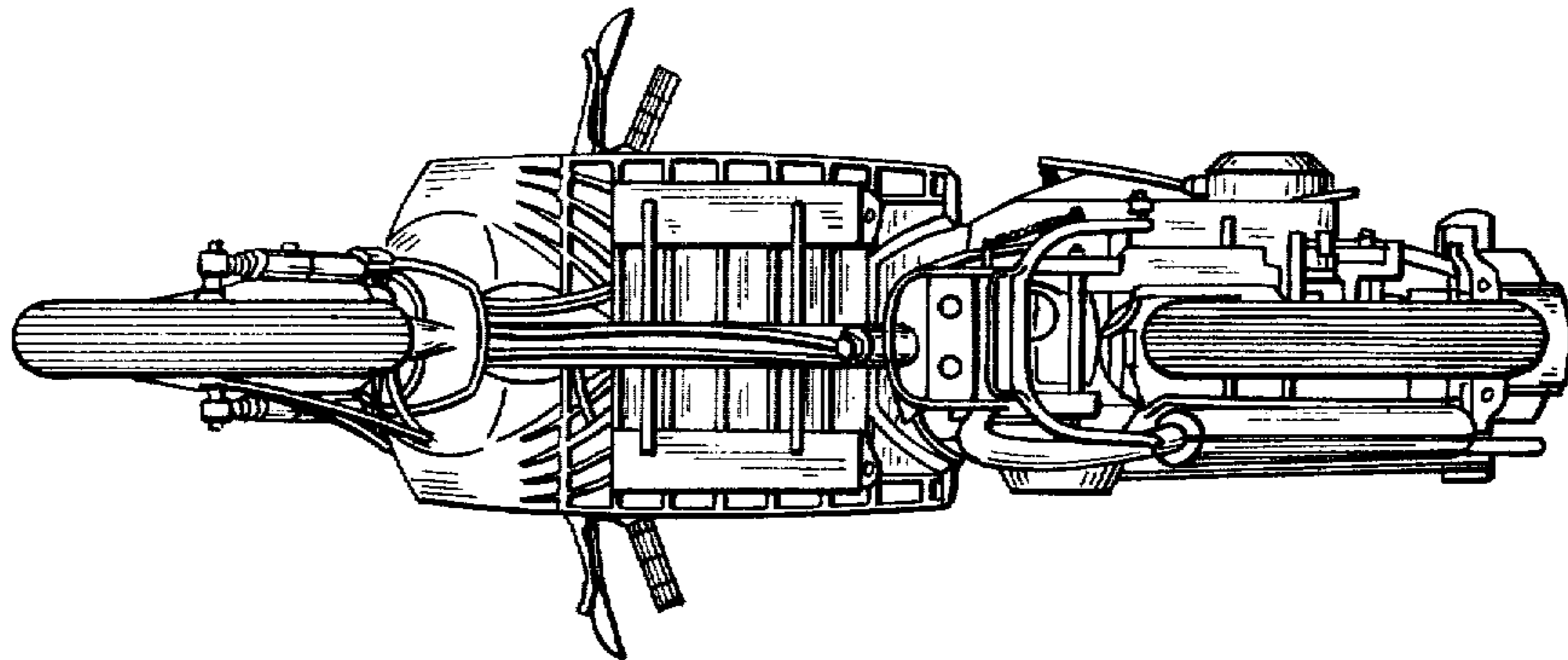

FIG.6

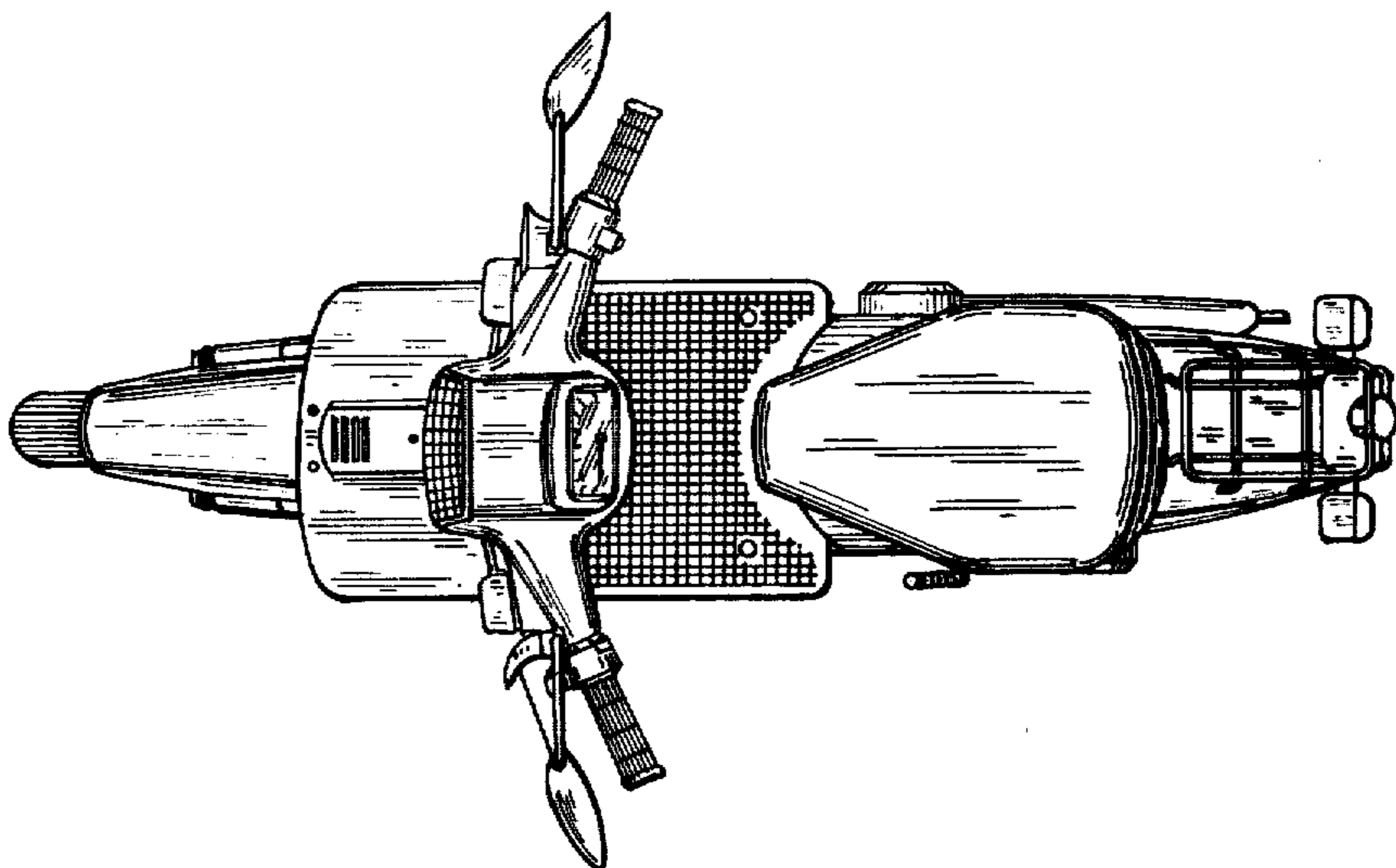

FIG.7

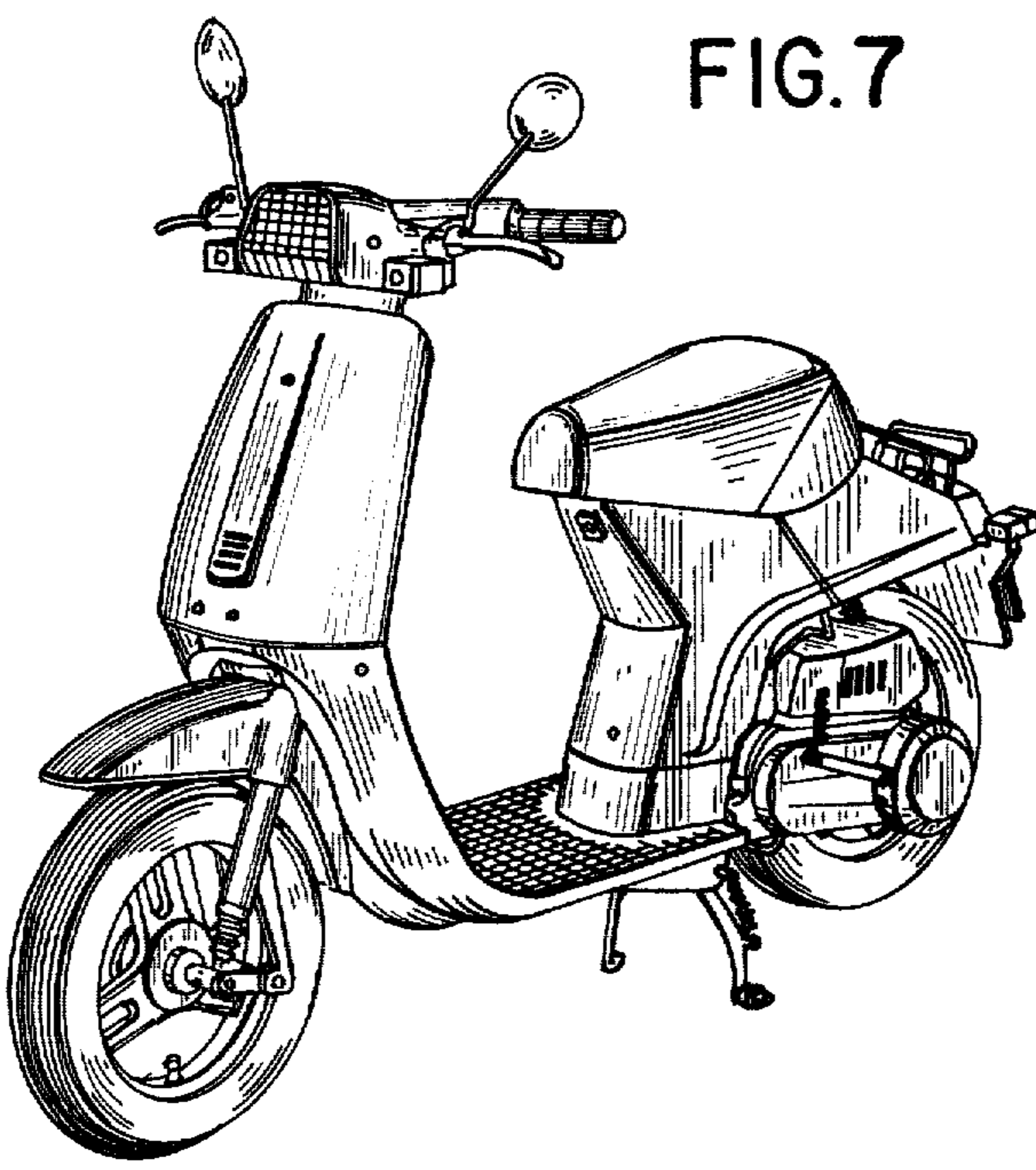

FIG.8

