

[54] MOTORCYCLE

[75] Inventors: Yoshihiko Aoyama; Makoto Kitagawa, both of Tokyo, Japan

[73] Assignee: Honda Giken Kogyo Kabushiki Kaisha, Honda Motor Co., Ltd., Tokyo, Japan

[**] Term: 14 Years

[21] Appl. No.: 195,074

[22] Filed: Oct. 8, 1980

[30] Foreign Application Priority Data

Apr. 15, 1980 [JP] Japan 55-14885

[51] Int. Cl. D12-11

[52] U.S. Cl. D12/110

[58] Field of Search D12/110; 180/219

[56] References Cited

PUBLICATIONS

- Cycle World, 2/79, p.14, Honda XR250.
- Cycle World, 7/79, p. 79, Maico 450 Magnum.

Cycle World, 6/78, p. 73, Honda XL-2505.
Moto Revue, 11/29/79, p. 59, Yamaha 465YX & 125YZ.

Moto Revue, 11/29/79, p. 65, Honda, center left side of page.

Motorcyclist, 10/79, p. 89, Suzuki RM250 & Honda CR205R.

Motorcyclist, 10/79, p. 90, Kawasaki KX250.

Primary Examiner—James M. Gandy
Attorney, Agent, or Firm—Armstrong, Nikaido, Marmelstein & Kubovcik

[57] CLAIM

The ornamental design for a motorcycle, as shown.

DESCRIPTION

- FIG. 1 is a top plan view of our new design for a motorcycle;
- FIG. 2 is a left side elevational view thereof;
- FIG. 3 is a front elevational view thereof;
- FIG. 4 is a rear elevational view thereof;
- FIG. 5 is a right side elevational view thereof;
- FIG. 6 is a bottom plan view thereof; and
- FIG. 7 is a perspective view thereof.

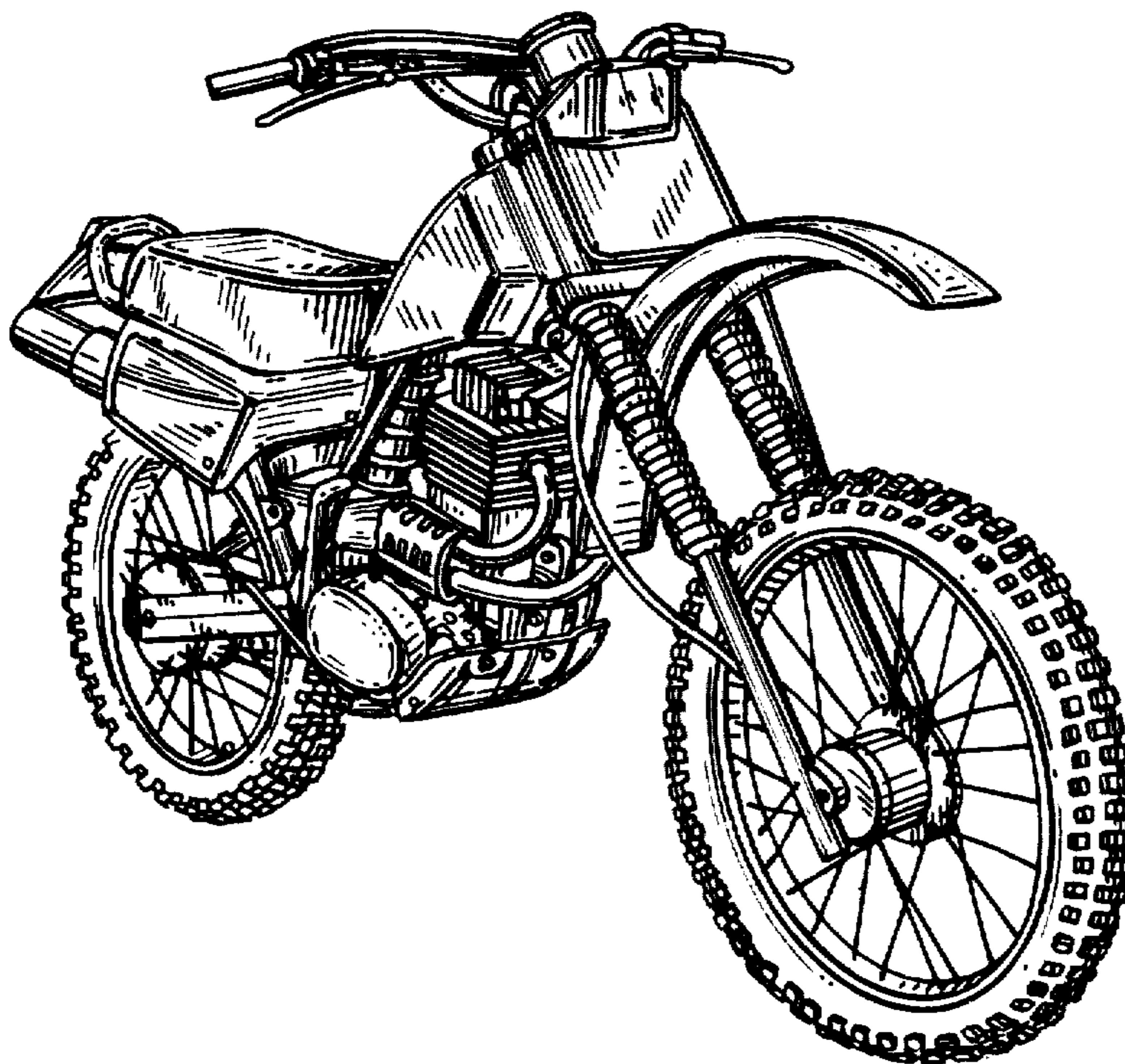

FIG. 1

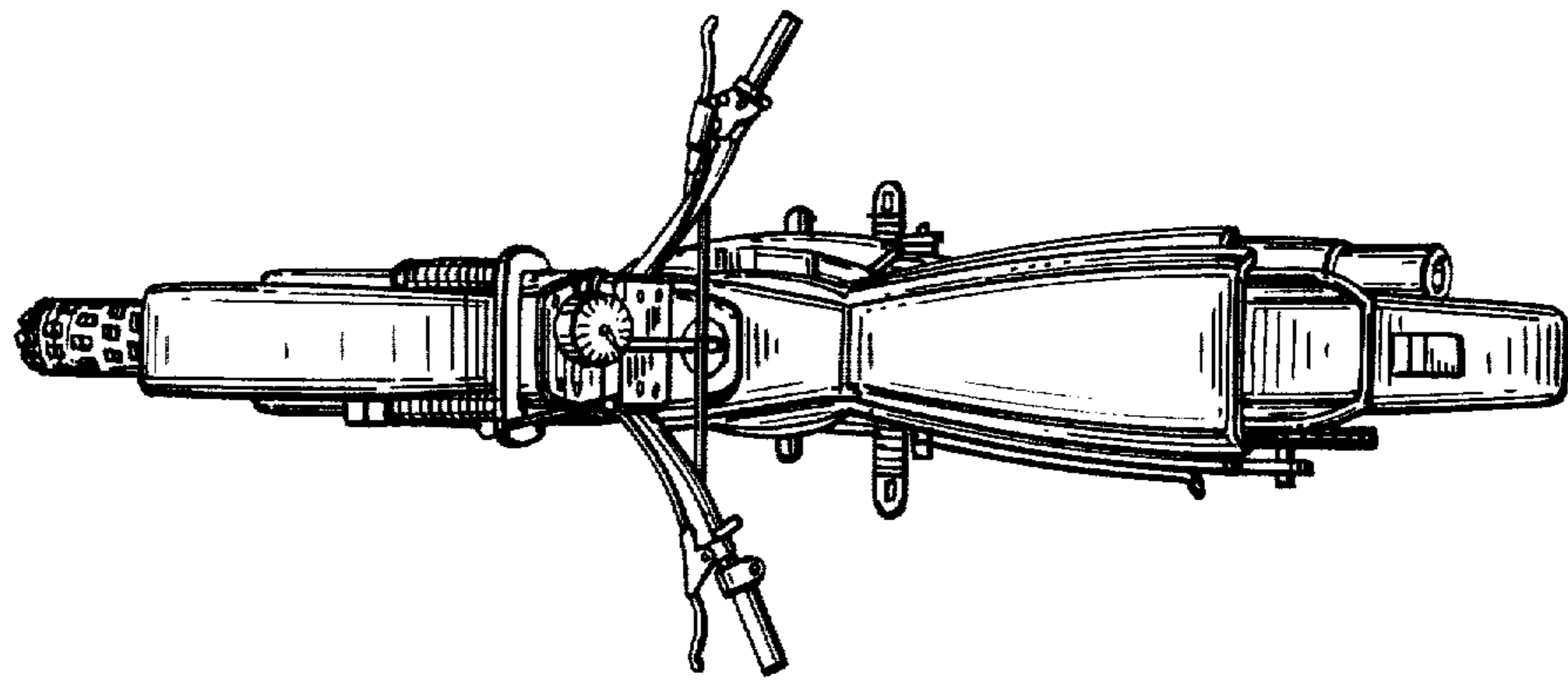

FIG. 2

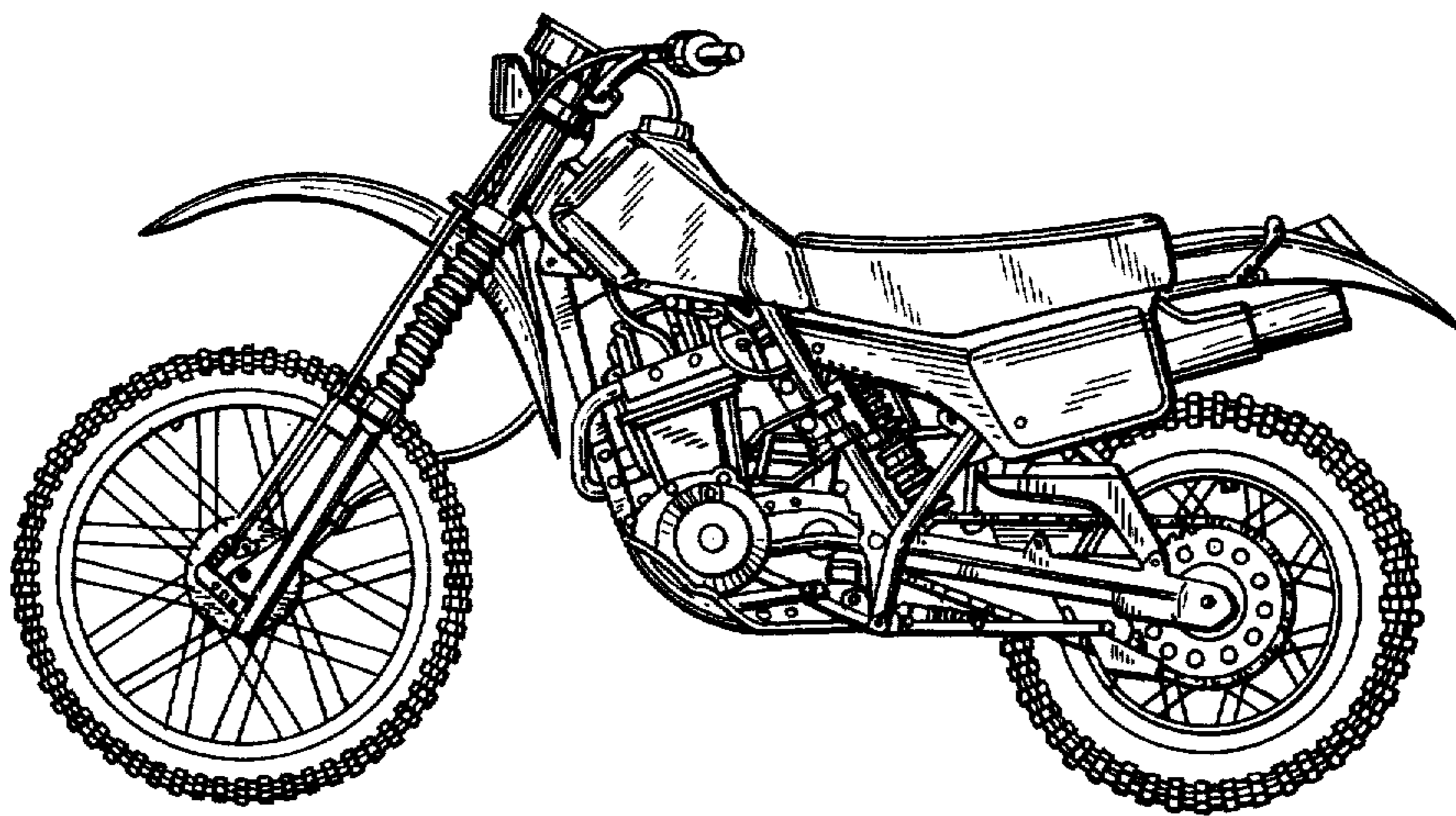

FIG. 3

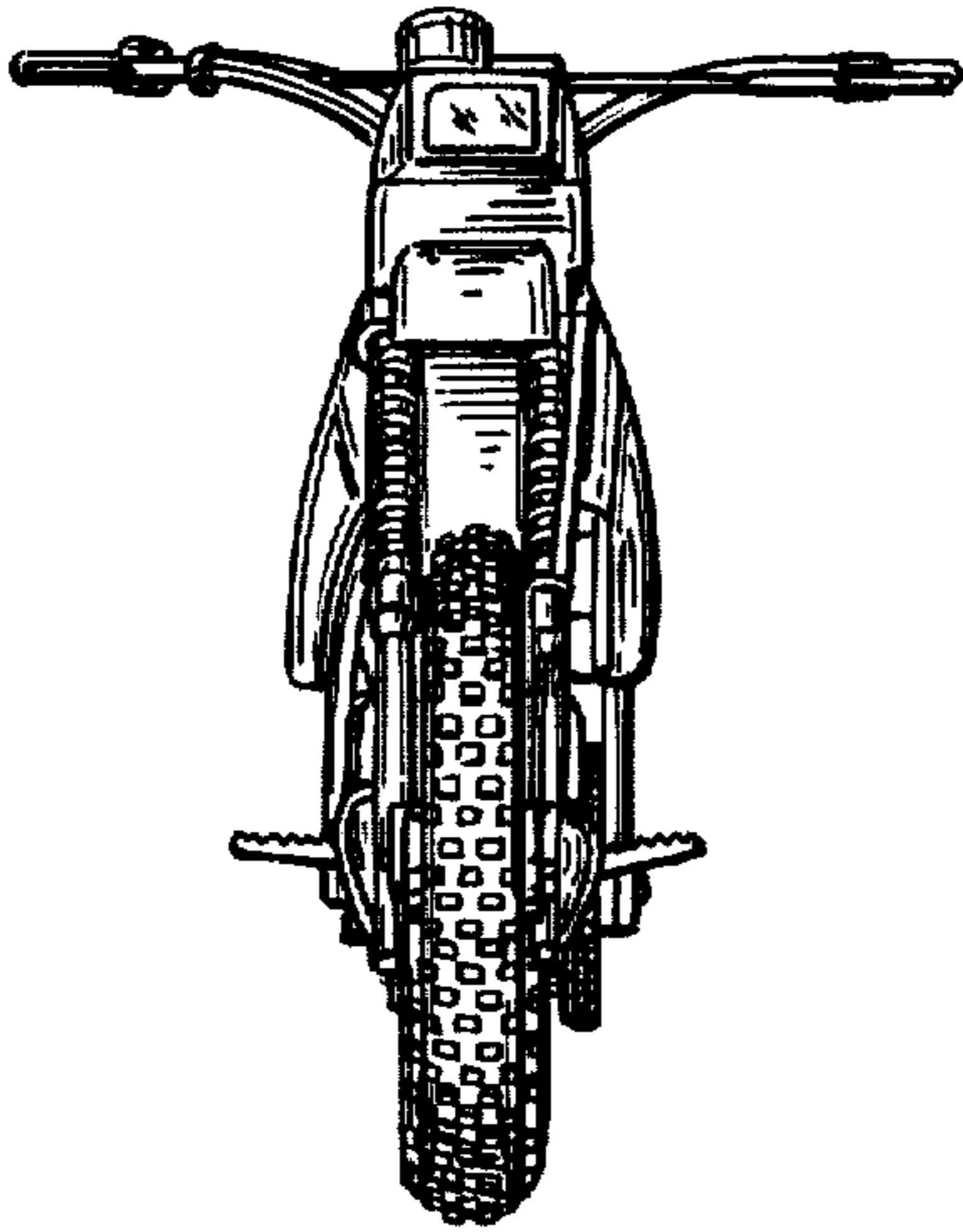

FIG. 4

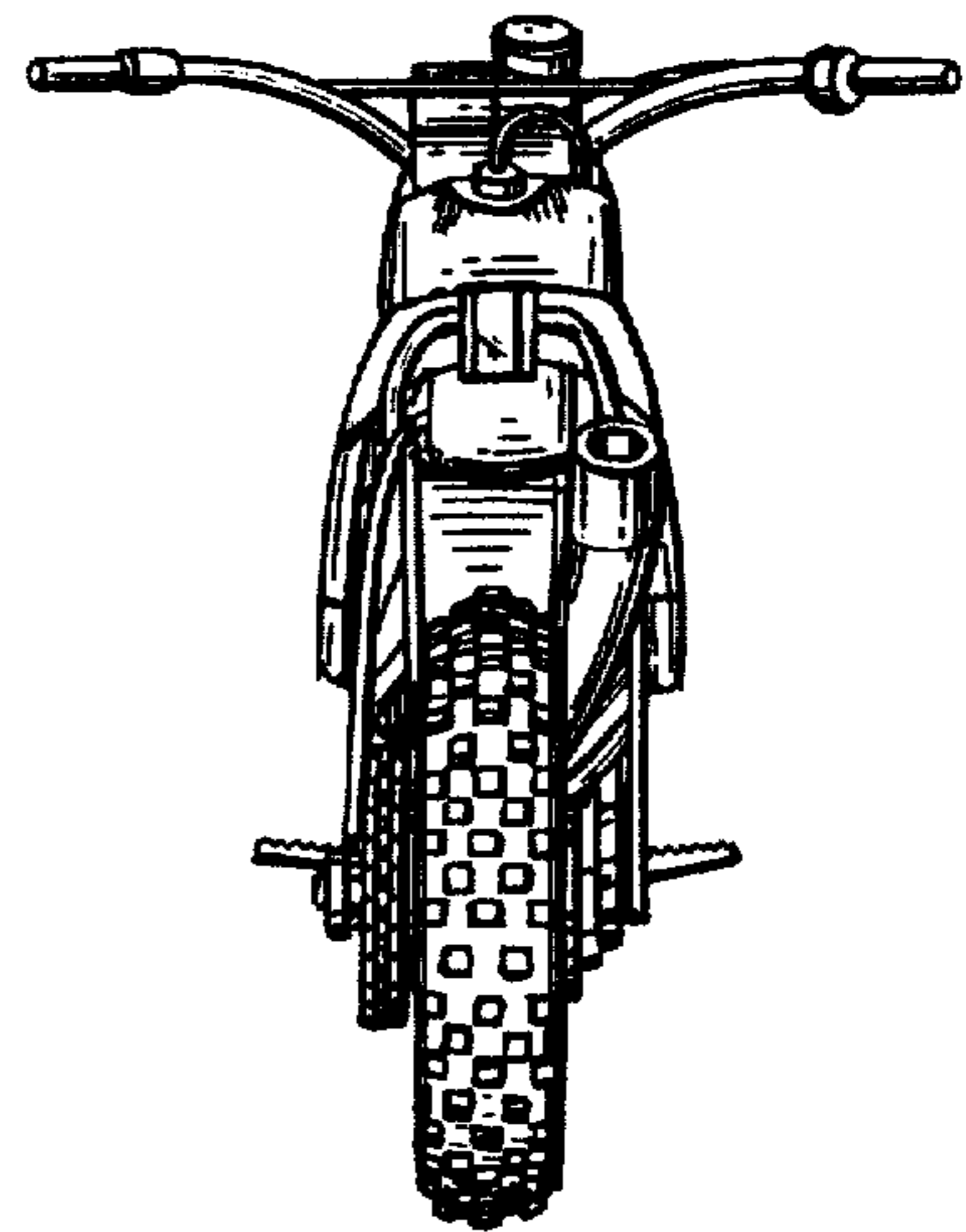

FIG. 5

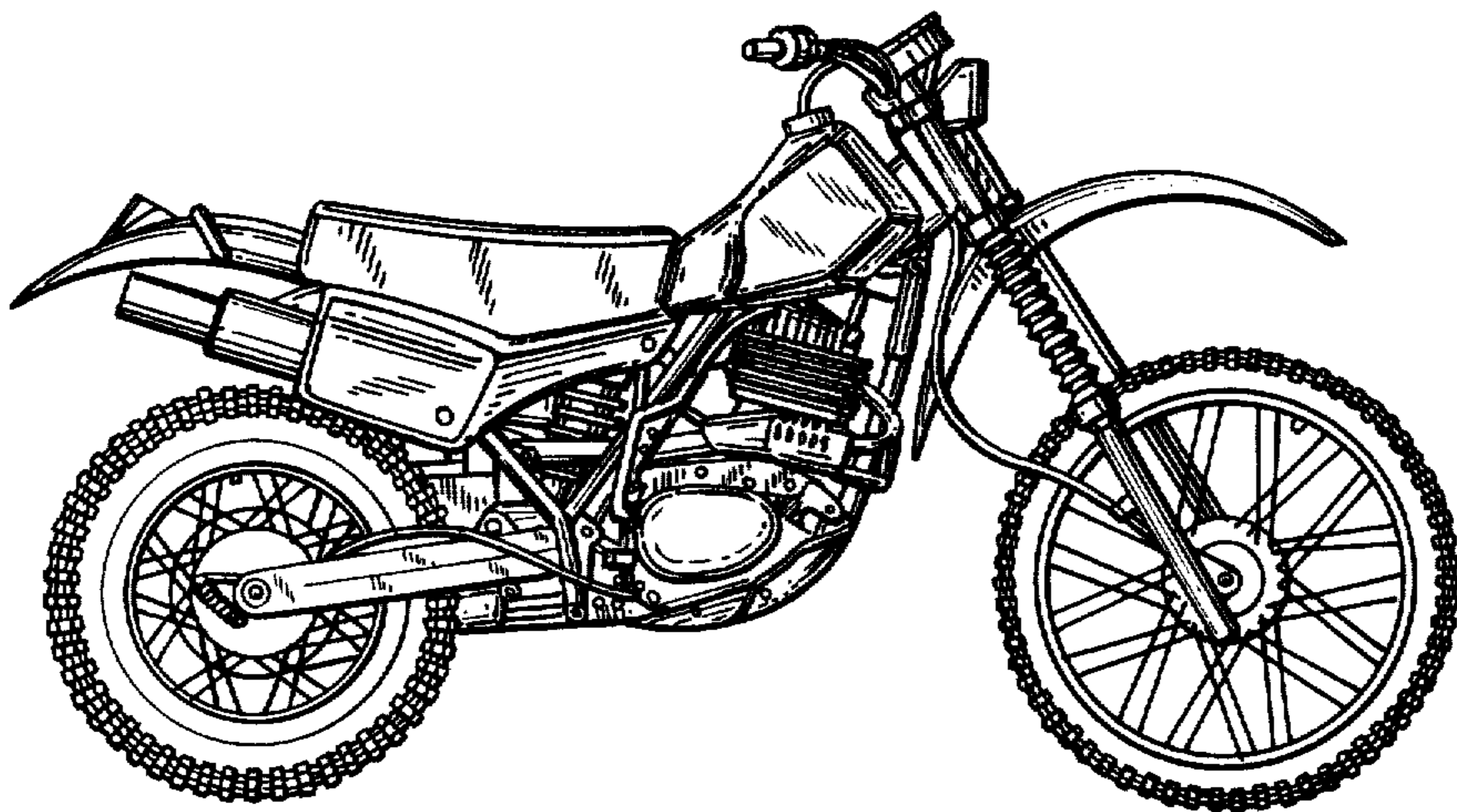

FIG. 6

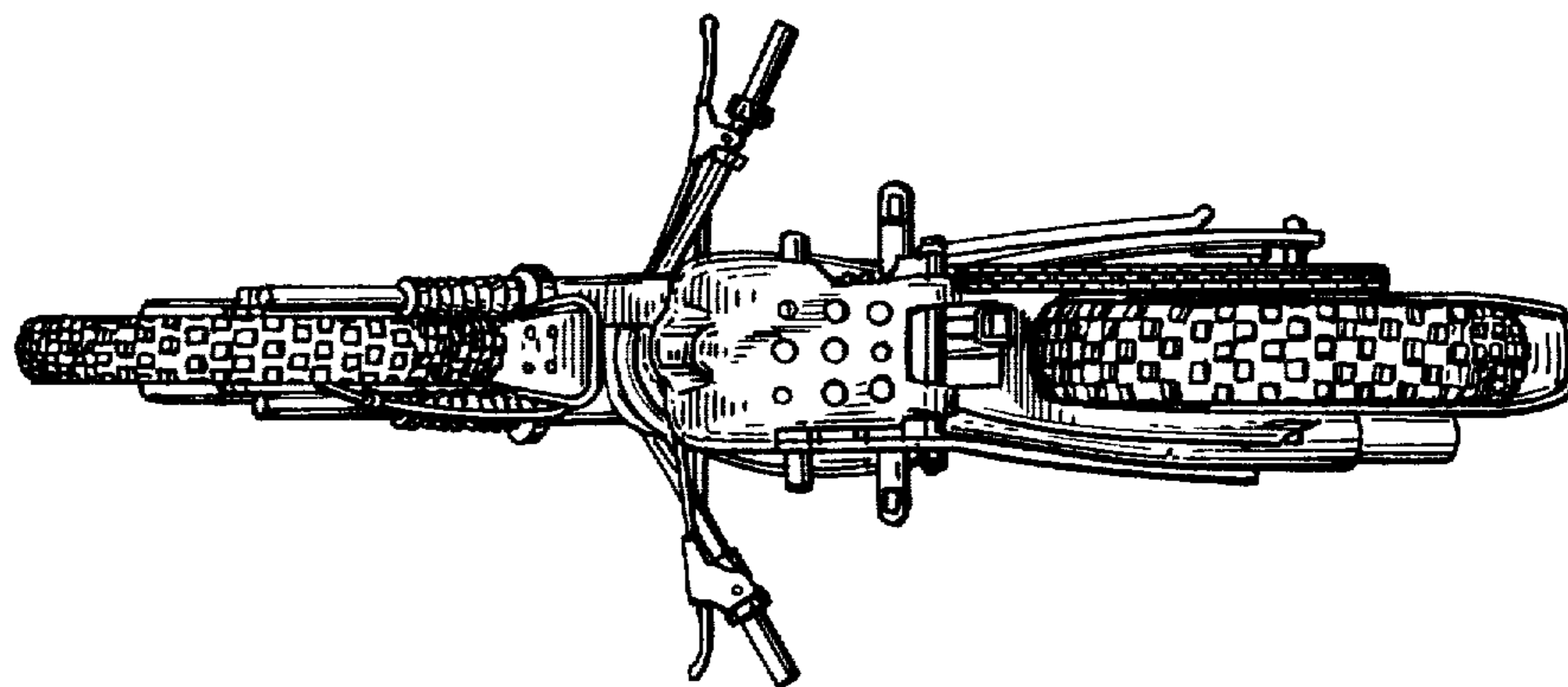

FIG. 7

