

[54] **MOTORCYCLE**

[75] **Inventors:** Kouji Nakano, Kawagoe; Makoto Kodama, Kodaira, both of Japan

[73] **Assignee:** Honda Giken Kogyo Kabushiki Kaisha, Tokyo, Japan

[**] **Term:** 14 Years

[21] **Appl. No.:** 246,054

[22] **Filed:** Mar. 20, 1981

[30] **Foreign Application Priority Data**

Sep. 23, 1980 [JP] Japan 55-39432

[51] **Int. Cl.** D12-11

[52] **U.S. Cl.** D12/110

[58] **Field of Search** D12/110; 180/219

[56]

References Cited

PUBLICATIONS

Cycle World, 7/74, p. 23, Eliminator Cafe/Street Racer.

Cycle World, 2/79, p. 120, Honda CB750F.

Cycle World, 6/80, pp. 28 & 29, Honda CB750 Custom.

Cycle World, 6/80, Suzuki Flyer of GS-1100ET Motorcycle.

Primary Examiner—James M. Gandy

Attorney, Agent, or Firm—Armstrong, Nikaido,

Marmelstein & Kubovcik

[57]

CLAIM

The ornamental design for a motorcycle, as shown.

DESCRIPTION

FIG. 1 is a left side elevational view of a motorcycle, showing our new design;

FIG. 2 is a right side elevational view thereof;

FIG. 3 is a front perspective view thereof;

FIG. 4 is a rear perspective view thereof;

FIG. 5 is a top perspective view thereof;

FIG. 6 is a bottom perspective view thereof; and

FIG. 7 is a perspective view thereof.

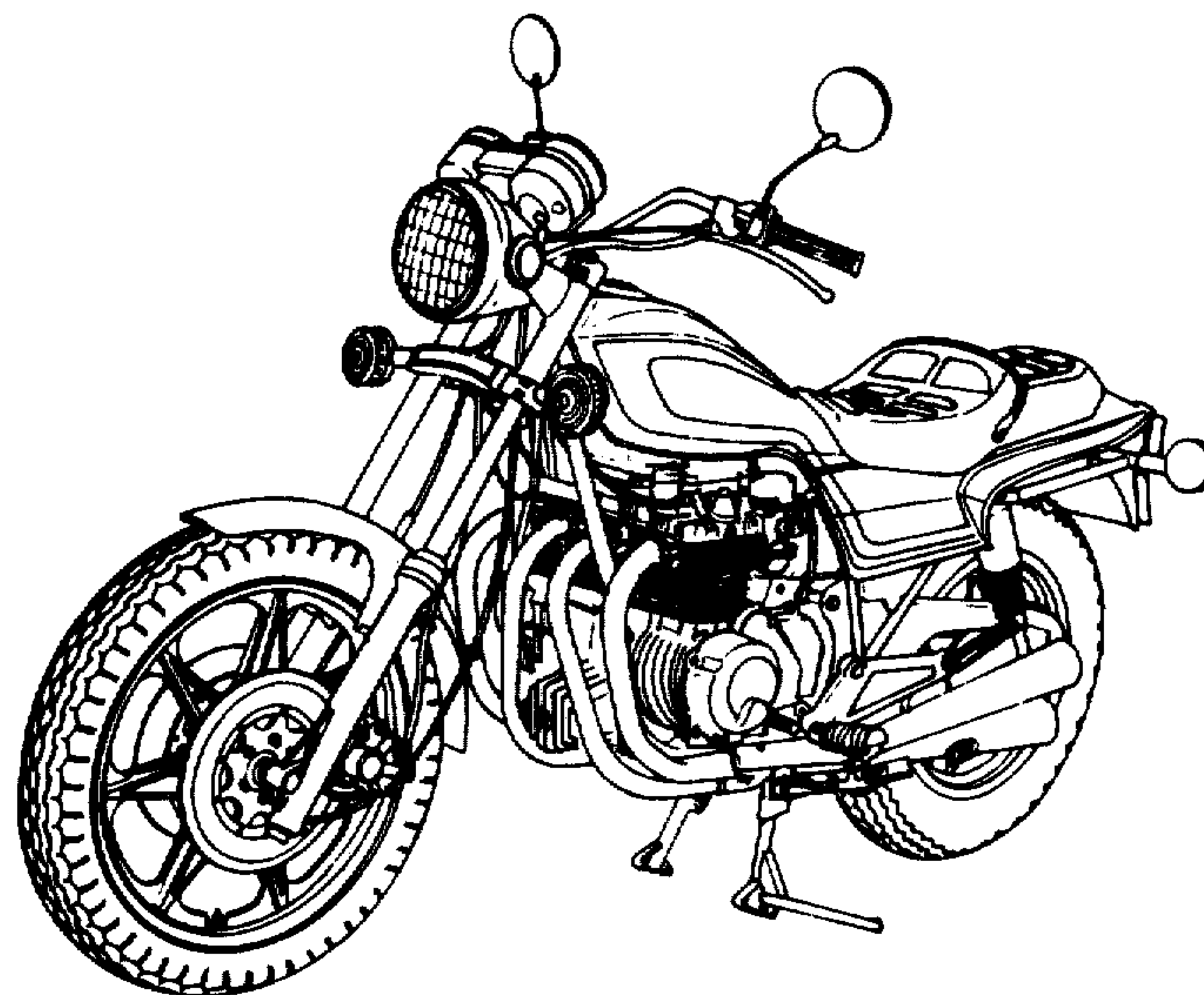

FIG. 1

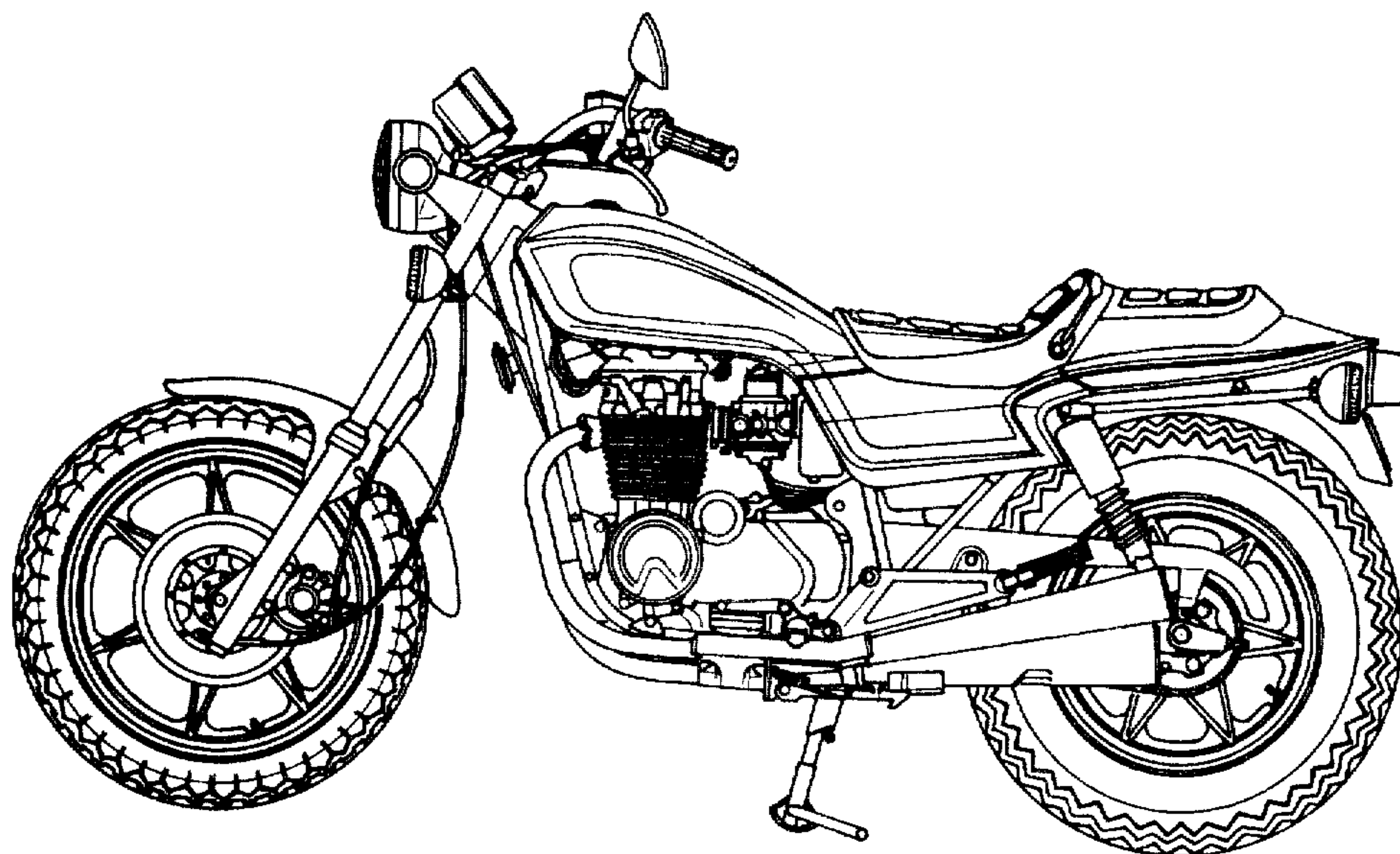

FIG. 2

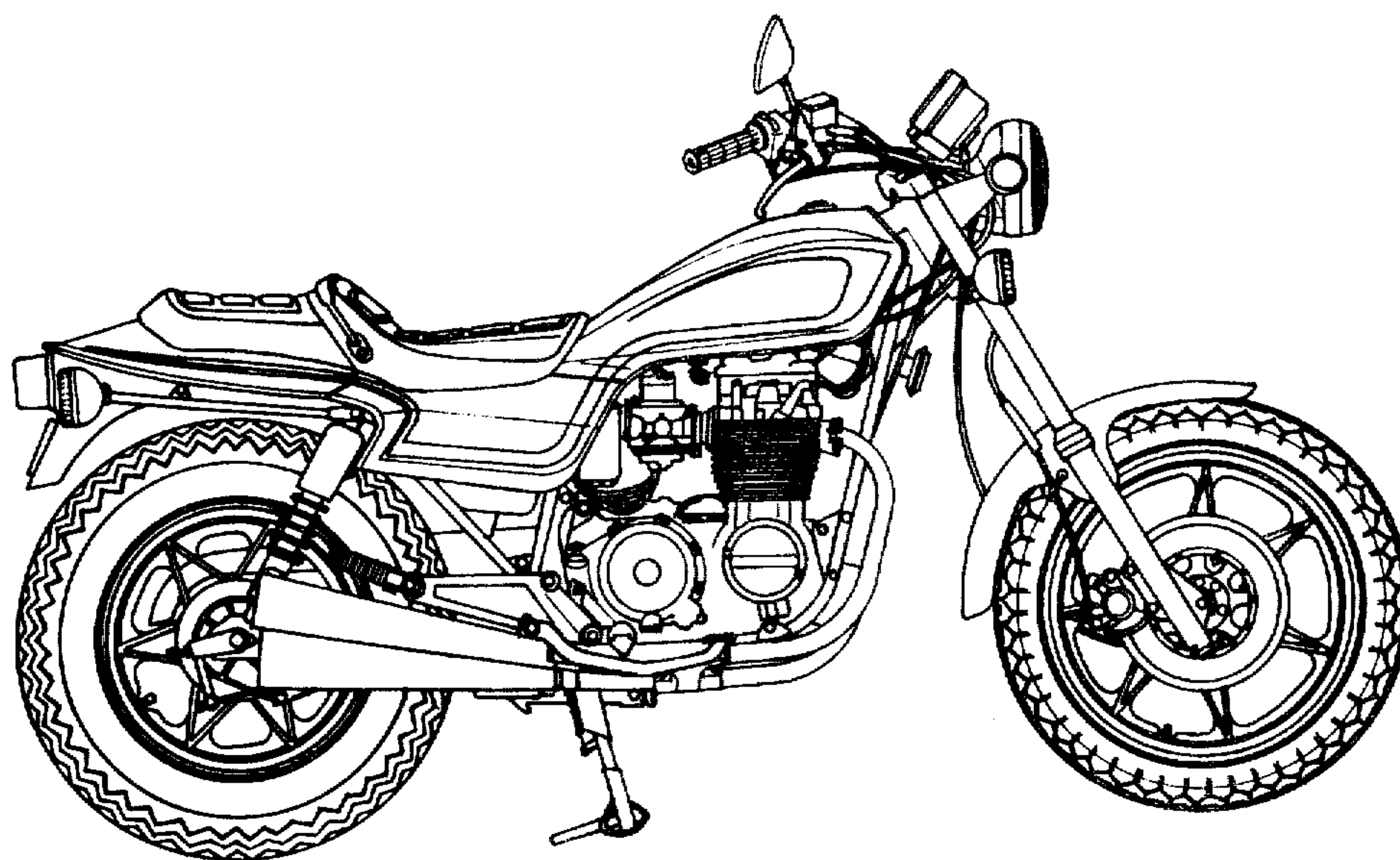

FIG. 3

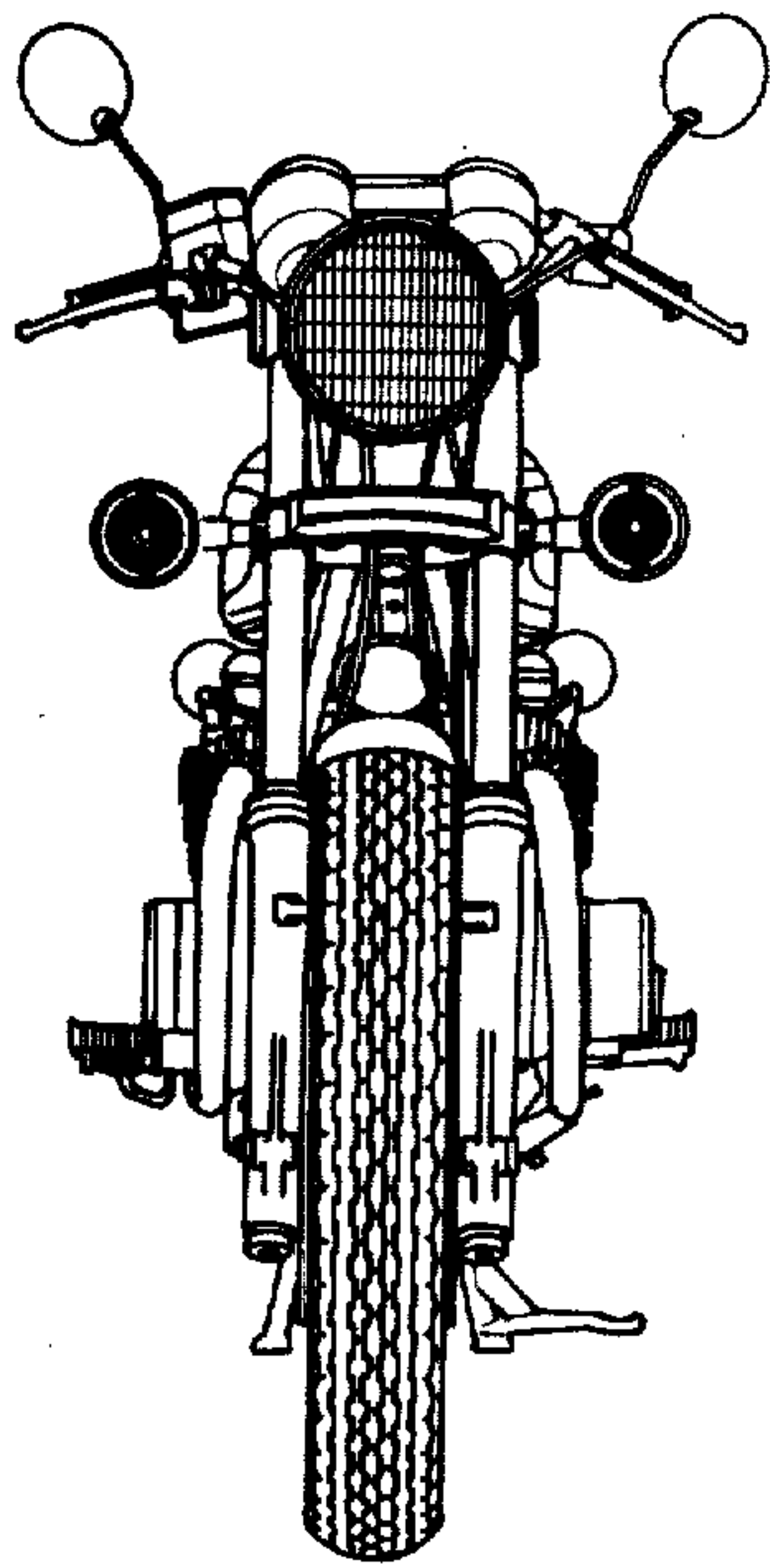

FIG. 4

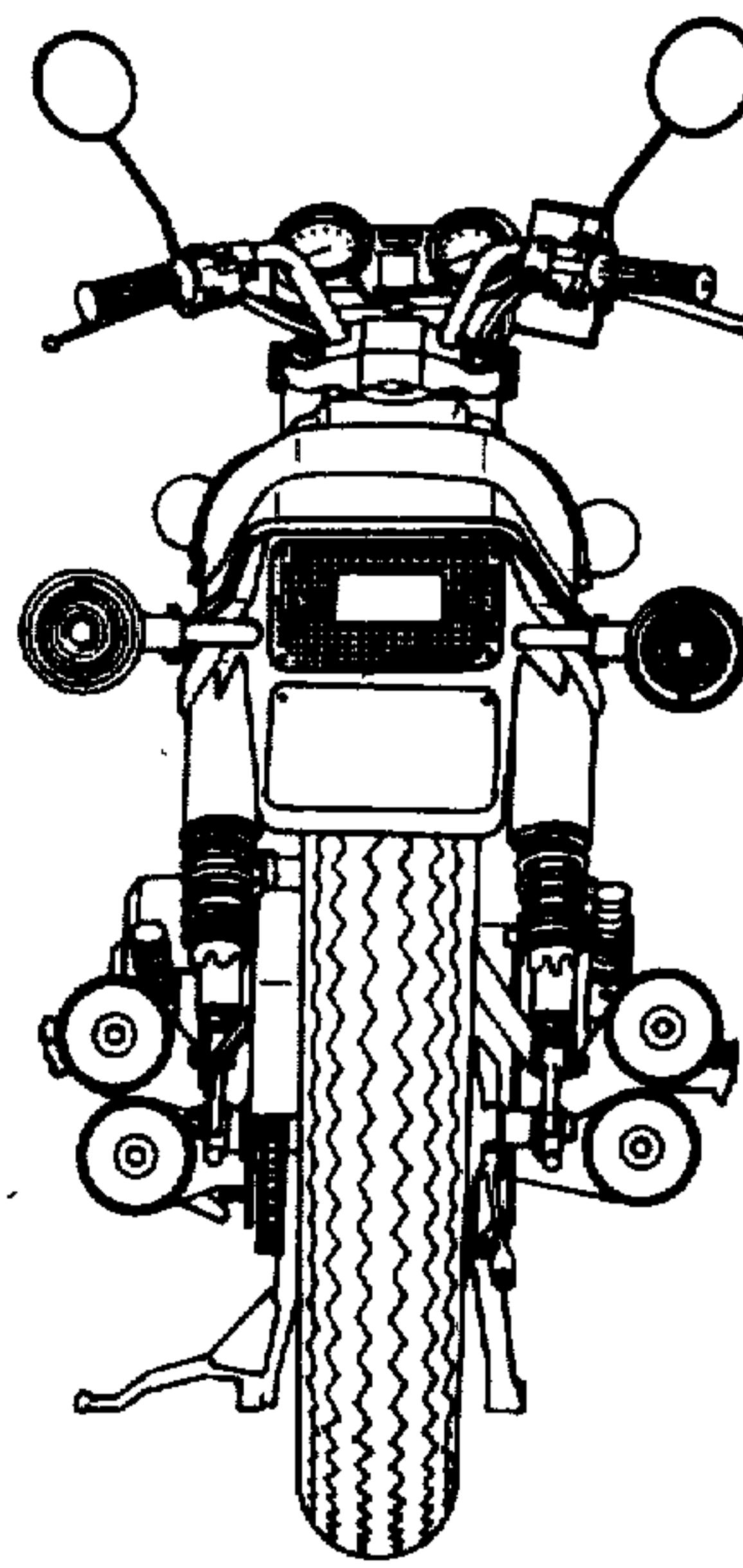

FIG. 5

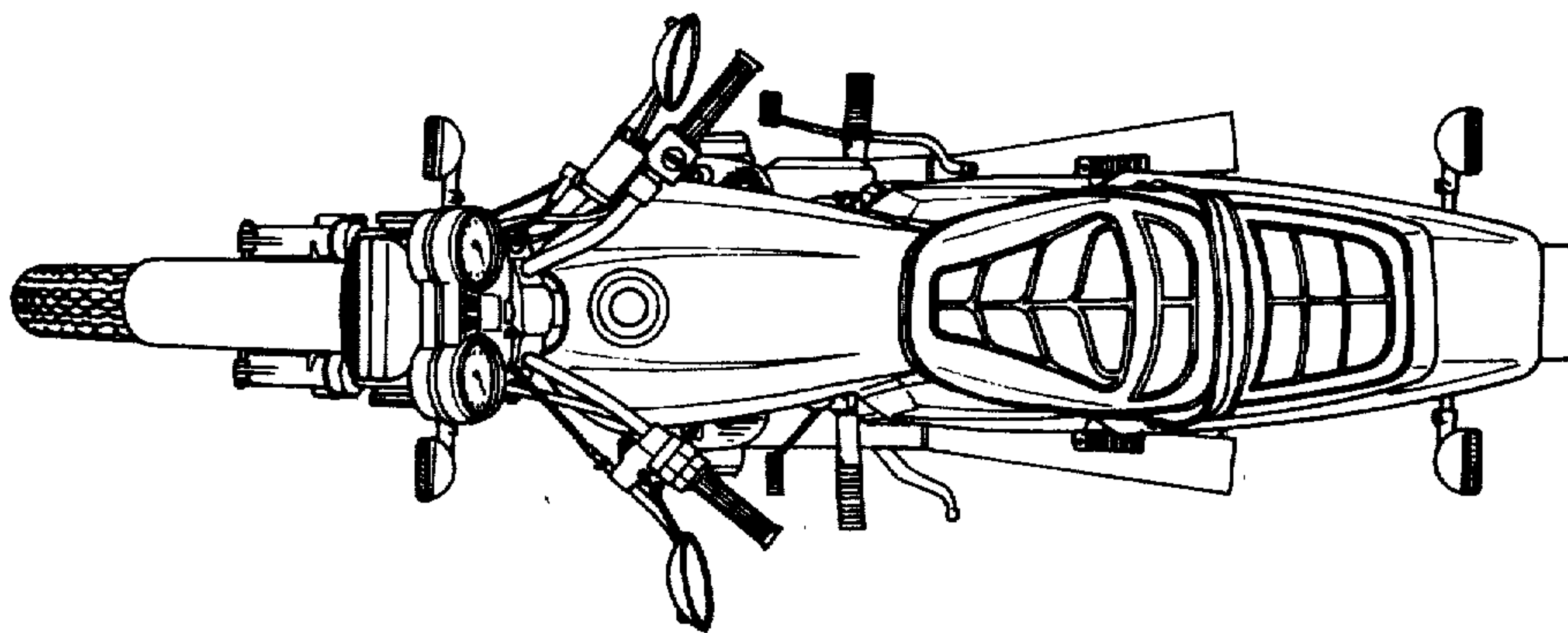

FIG. 6

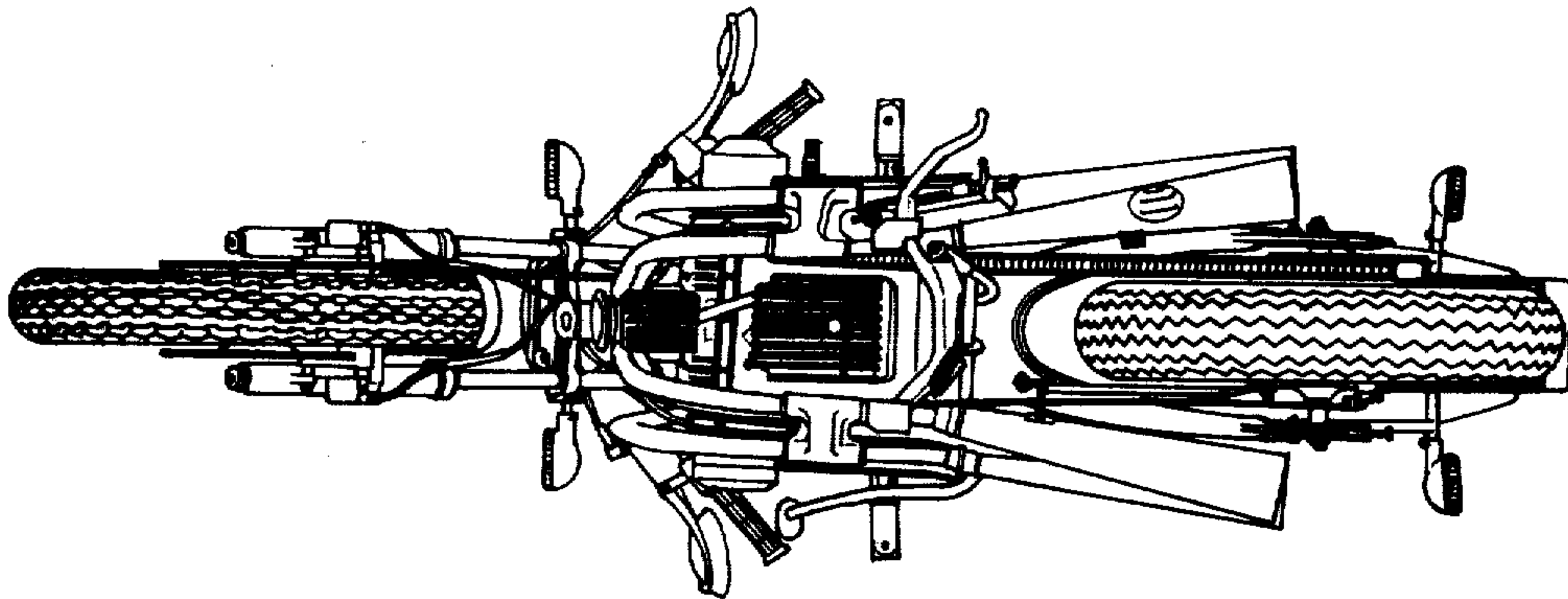

FIG. 7

