

[54] **MOTORCYCLE**

[75] **Inventors:** Koichiro Ban, Tachikawa; Tsunemi Kawashima, Tokyo; Kazunori Yamada, Machida; Toshiharu Shimizu, Tokorozawa, all of Japan

[73] **Assignee:** Yamaha Hatsudoki Kabushiki Kaisha, Japan

[\*\*] **Term:** 14 Years

[21] **Appl. No.:** 194,960

[22] **Filed:** Oct. 8, 1980

[30] **Foreign Application Priority Data**

Apr. 23, 1980 [JP] Japan ..... 55-16373

[51] **Int. Cl.** ..... D12-11

[52] **U.S. Cl.** ..... D12/110

[58] **Field of Search** ..... D12/110; 180/219, 223

[56] **References Cited**

**U.S. PATENT DOCUMENTS**

D. 252,141 6/1979 Matsuoka et al. .... D12/110  
D. 253,588 12/1979 Ban et al. .... D12/110

**OTHER PUBLICATIONS**

Design, 10/56, p. 25, Vespa Motorcycle, center right side of page.

*Primary Examiner*—James M. Gandy

[57] **CLAIM**

The ornamental design for a motorcycle, as shown.

**DESCRIPTION**

FIG. 1 is a right side elevational view of a motorcycle, showing our new design;

FIG. 2 is a left side elevational view thereof;

FIG. 3 is a front elevational view thereof;

FIG. 4 is a rear elevational view thereof;

FIG. 5 is a top plan view thereof; and

FIG. 6 is a front left side perspective view thereof.

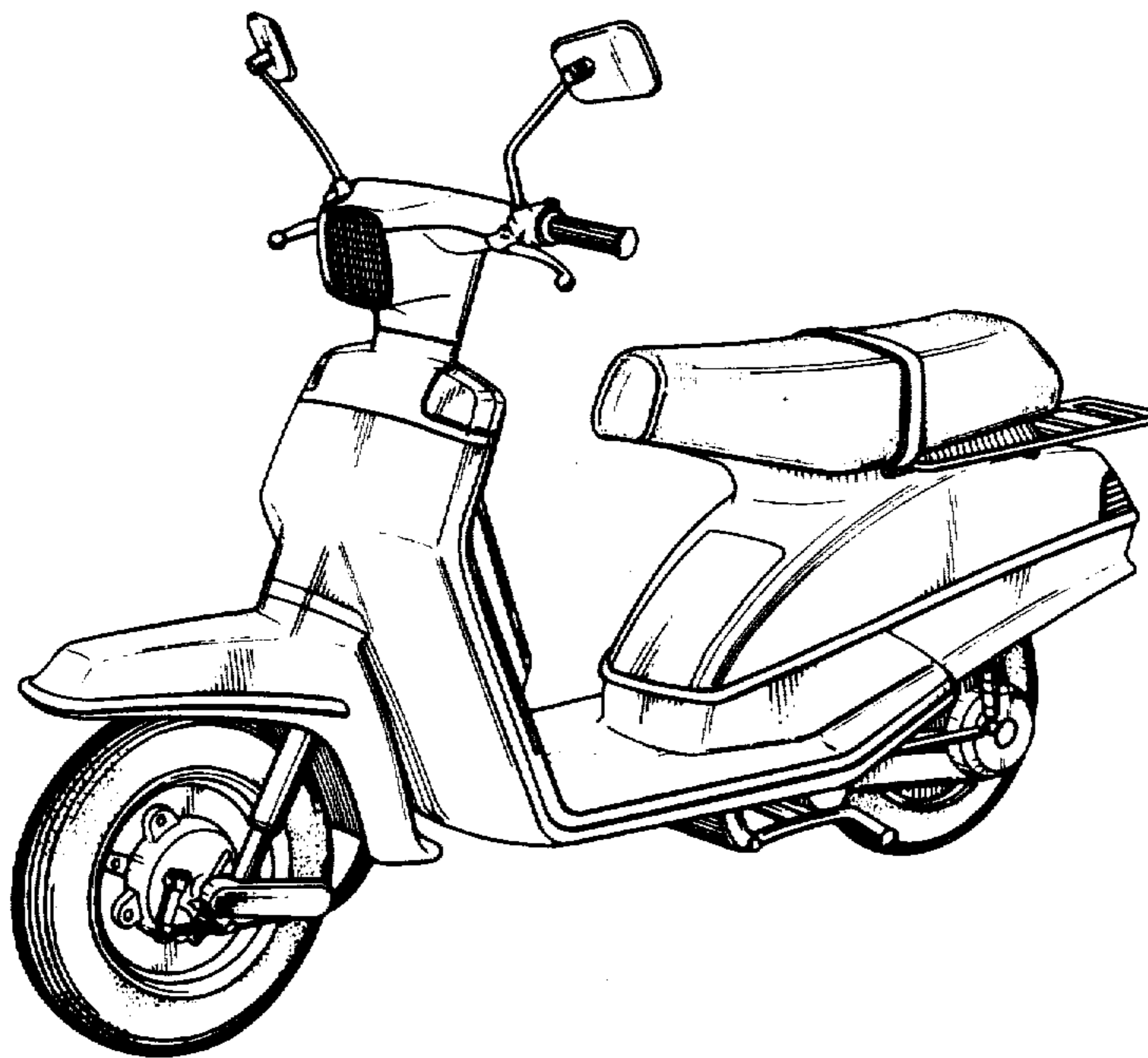

FIG. 1

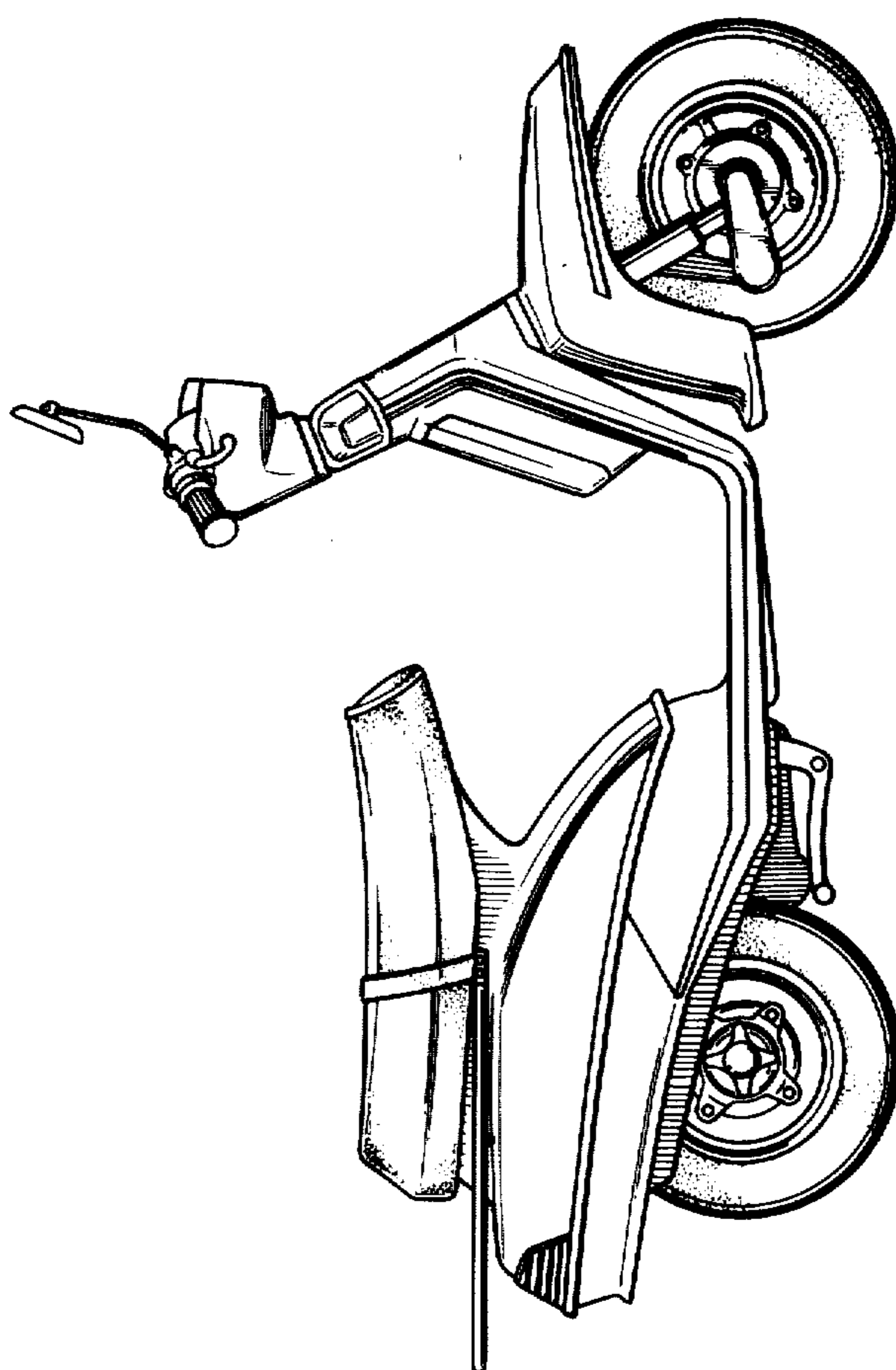

FIG.2

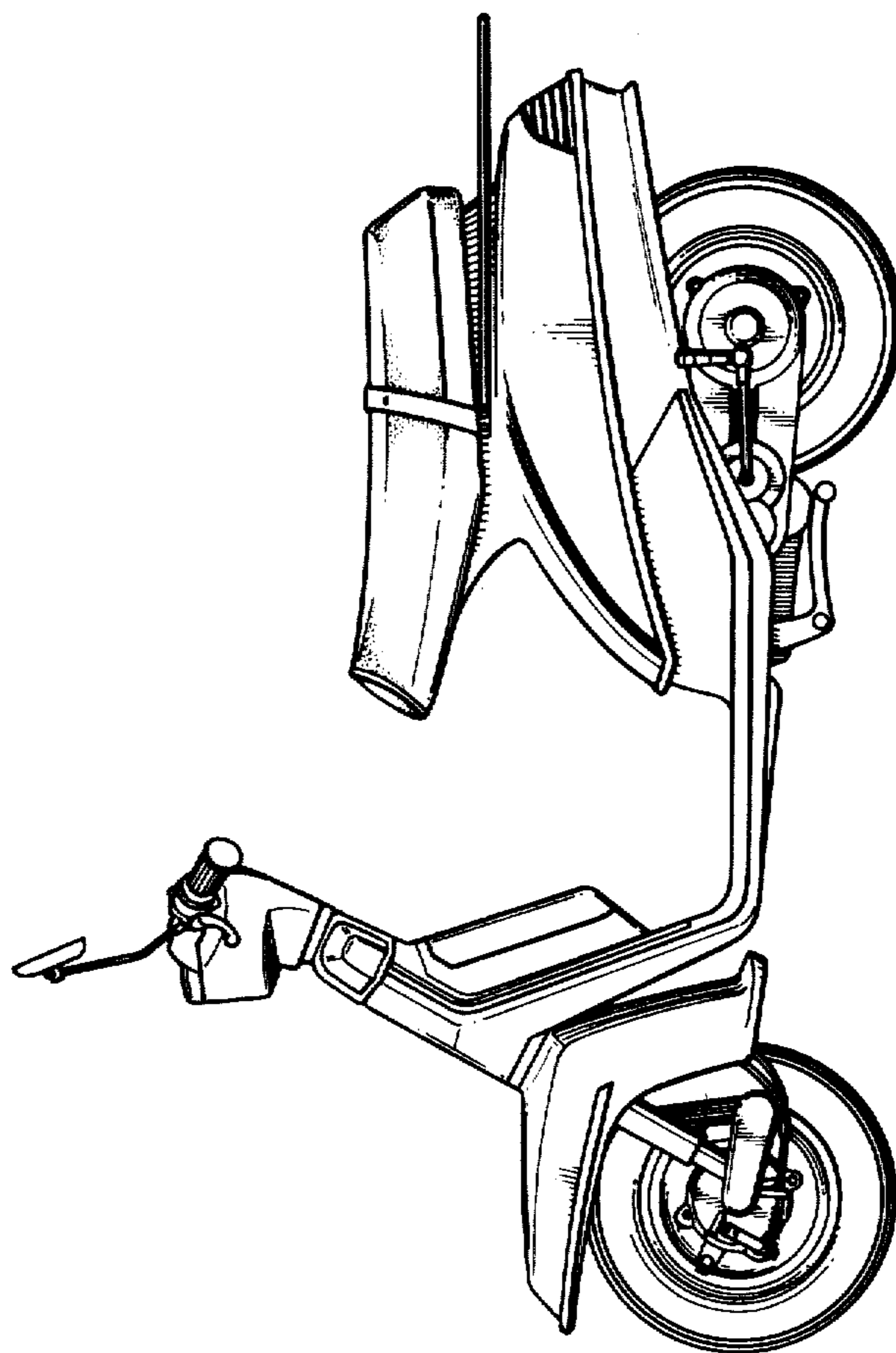

FIG.4

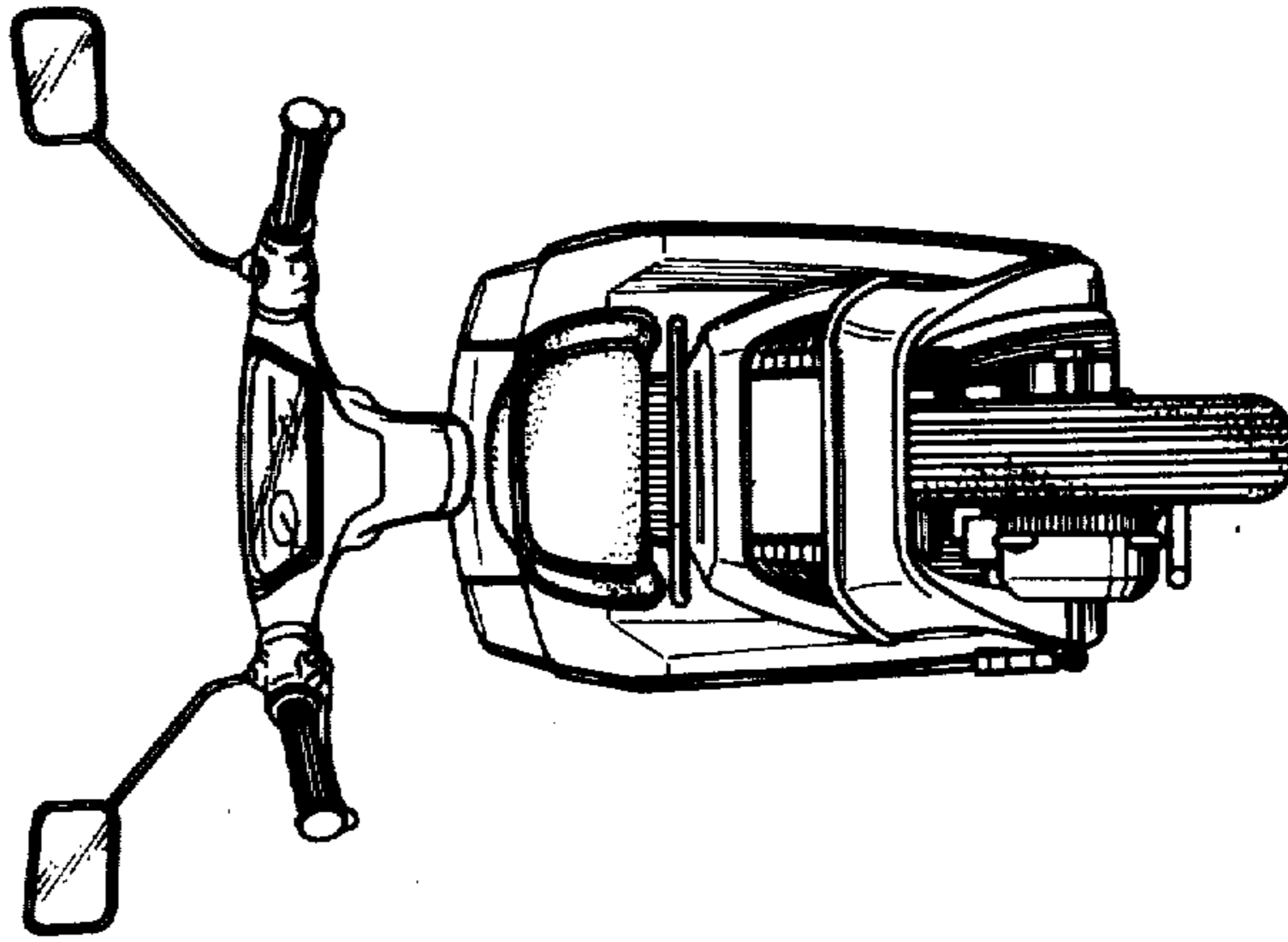

FIG.3

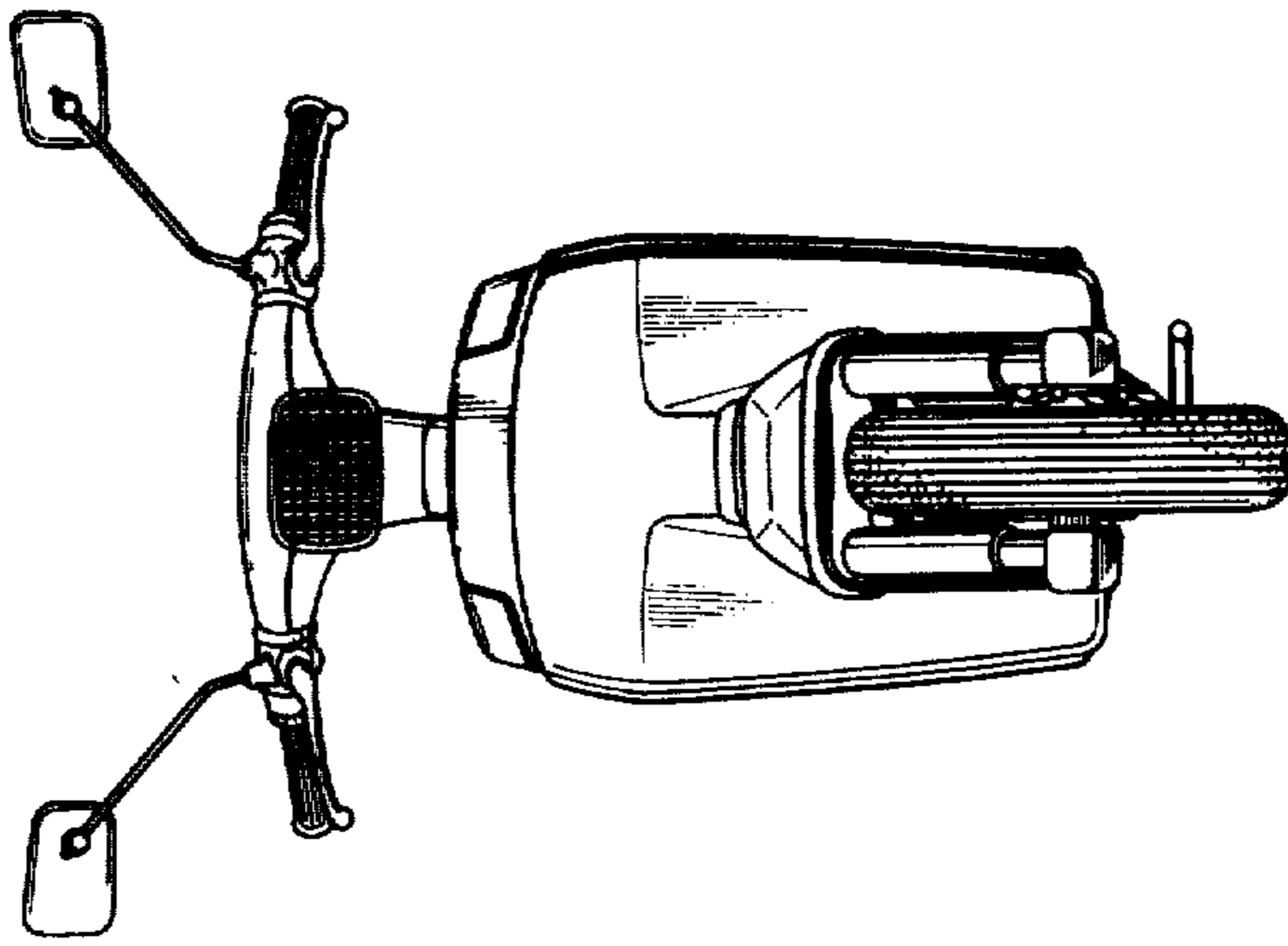
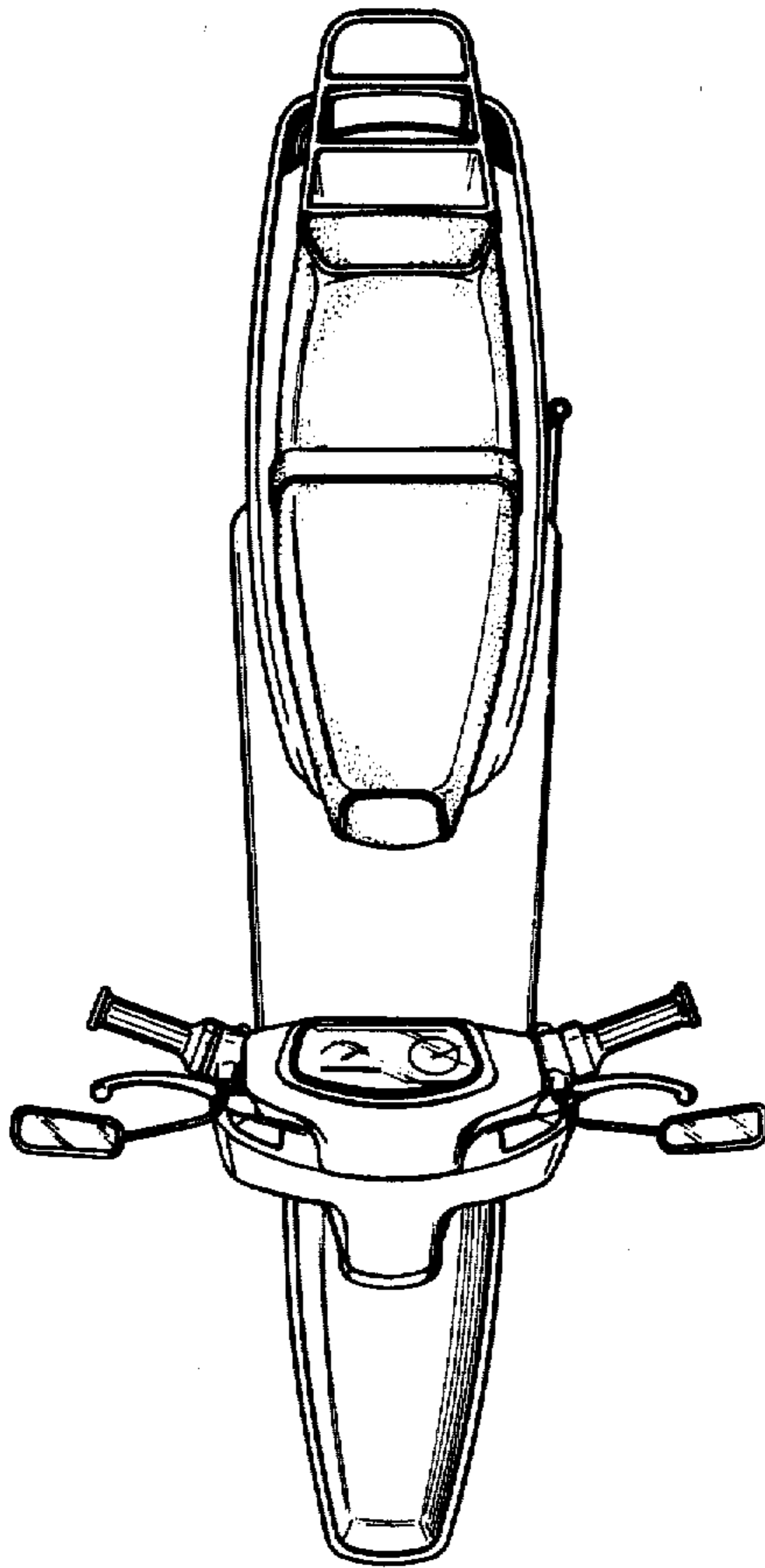

FIG.5



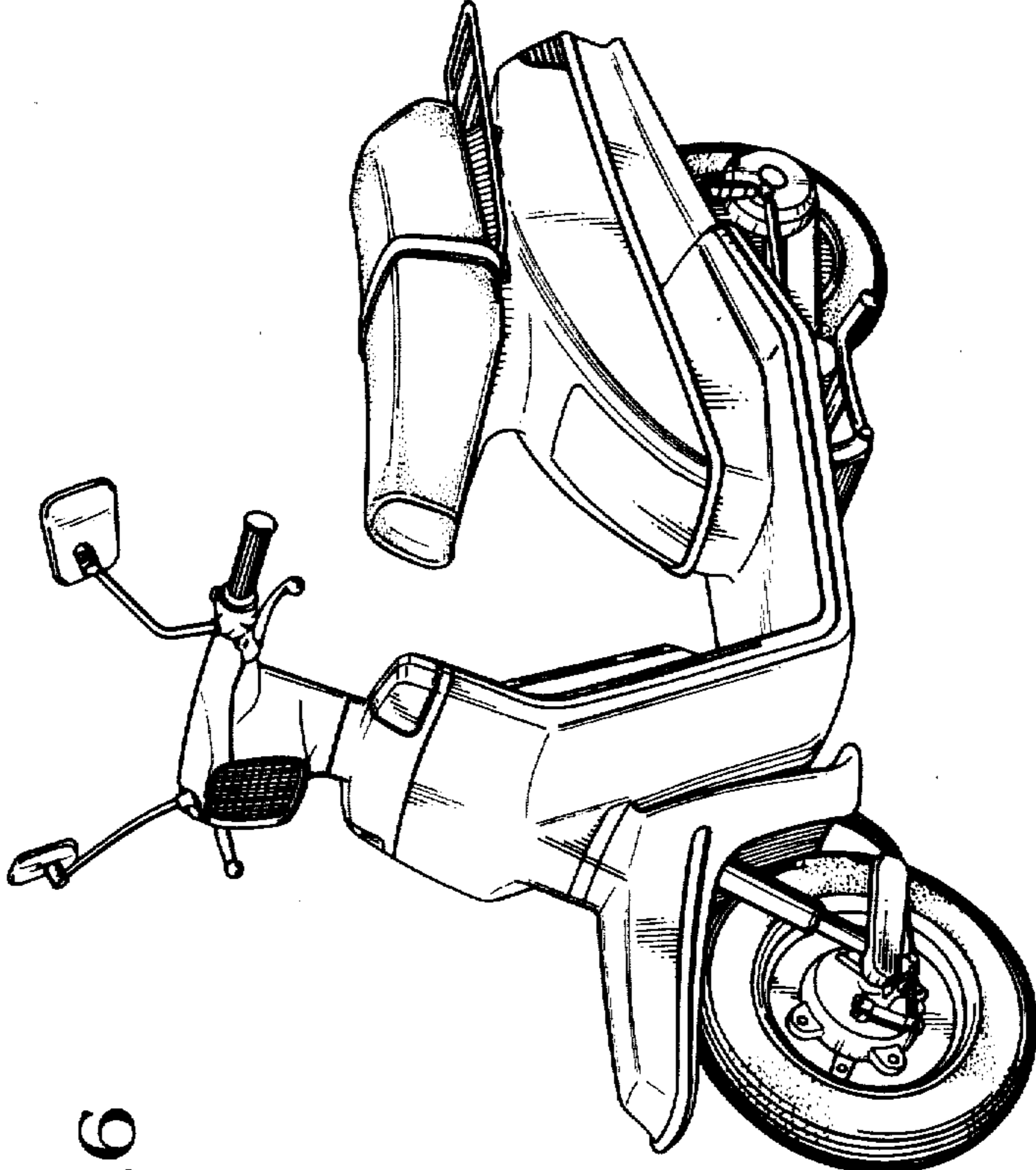

FIG.6