

[54] **BUS**

[75] **Inventor:** Yves Dubernard, Cerizay, France

[73] **Assignee:** S.A. Louis Heuliez, Cerizay, France

[**] **Term:** 14 Years

[21] **Appl. No.:** 143,457

[22] **Filed:** Apr. 24, 1980

[30] **Foreign Application Priority Data**

Jan. 26, 1978 [FR]	France	68
Dec. 20, 1978 [FR]	France	75
Nov. 2, 1979 [FR]	France	78

[51] **Int. Cl.** D12-08

[52] **U.S. Cl.** D12/84

[58] **Field of Search** D12/84; 296/178

[56]

References Cited

U.S. PATENT DOCUMENTS

D. 248,033 5/1978 James et al. D12/84
4,203,623 5/1980 Fenner et al. 296/178

FOREIGN PATENT DOCUMENTS

125120 1/1978 France .
128210 12/1978 France .

Primary Examiner—James M. Gandy
Attorney, Agent, or Firm—Andrus, Scales, Starke & Sawall

[57]

CLAIM

The ornamental design for a bus, as shown.

DESCRIPTION

FIG. 1 is a left front perspective view of a bus showing my new design;
FIG. 2 is a left rear perspective view thereof;
FIG. 3 is a left side elevational view thereof;
FIG. 4 is a right side elevational view thereof;
FIG. 5 is a rear elevational view thereof; and
FIG. 6 is a front elevational view thereof.

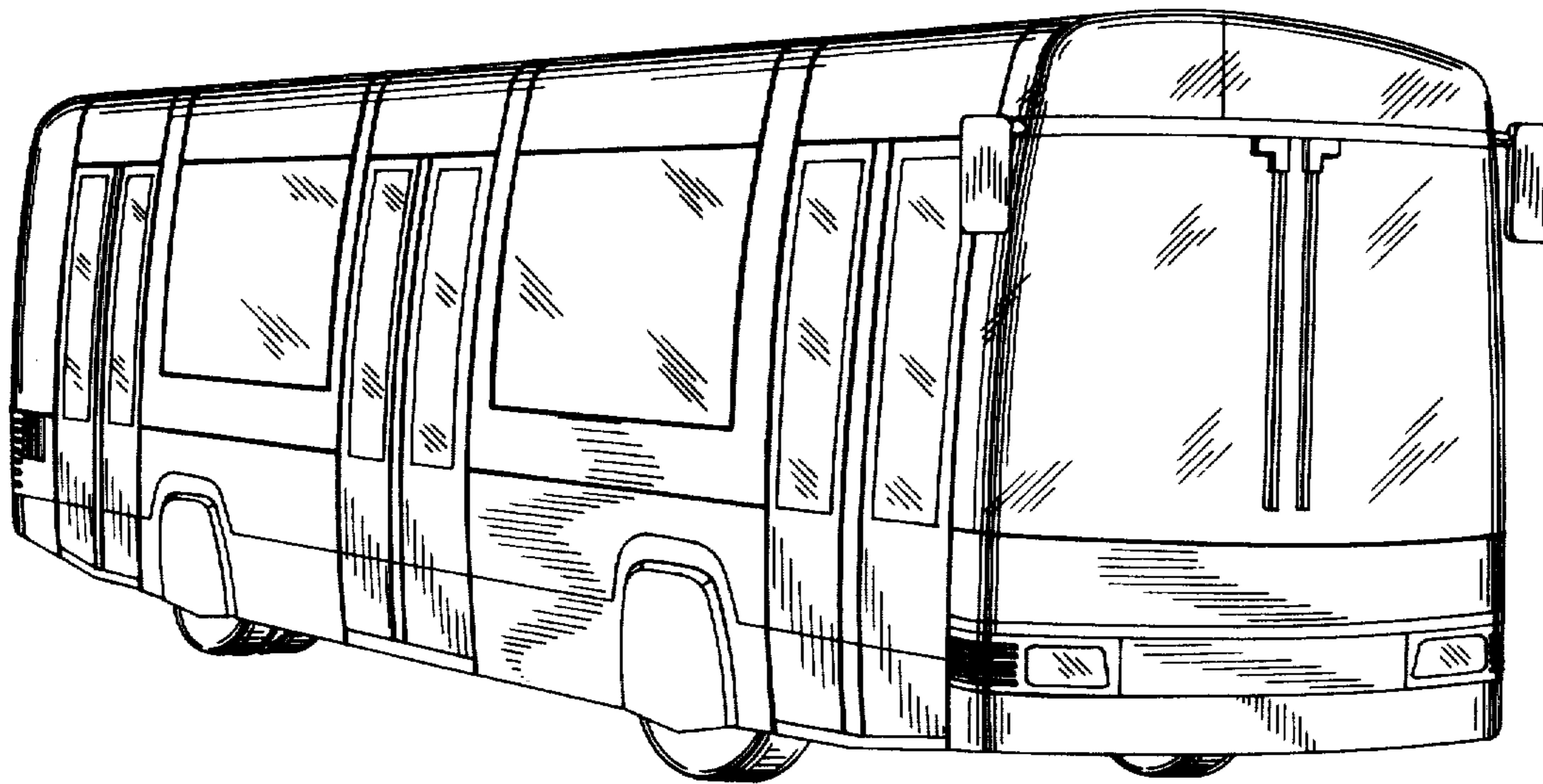

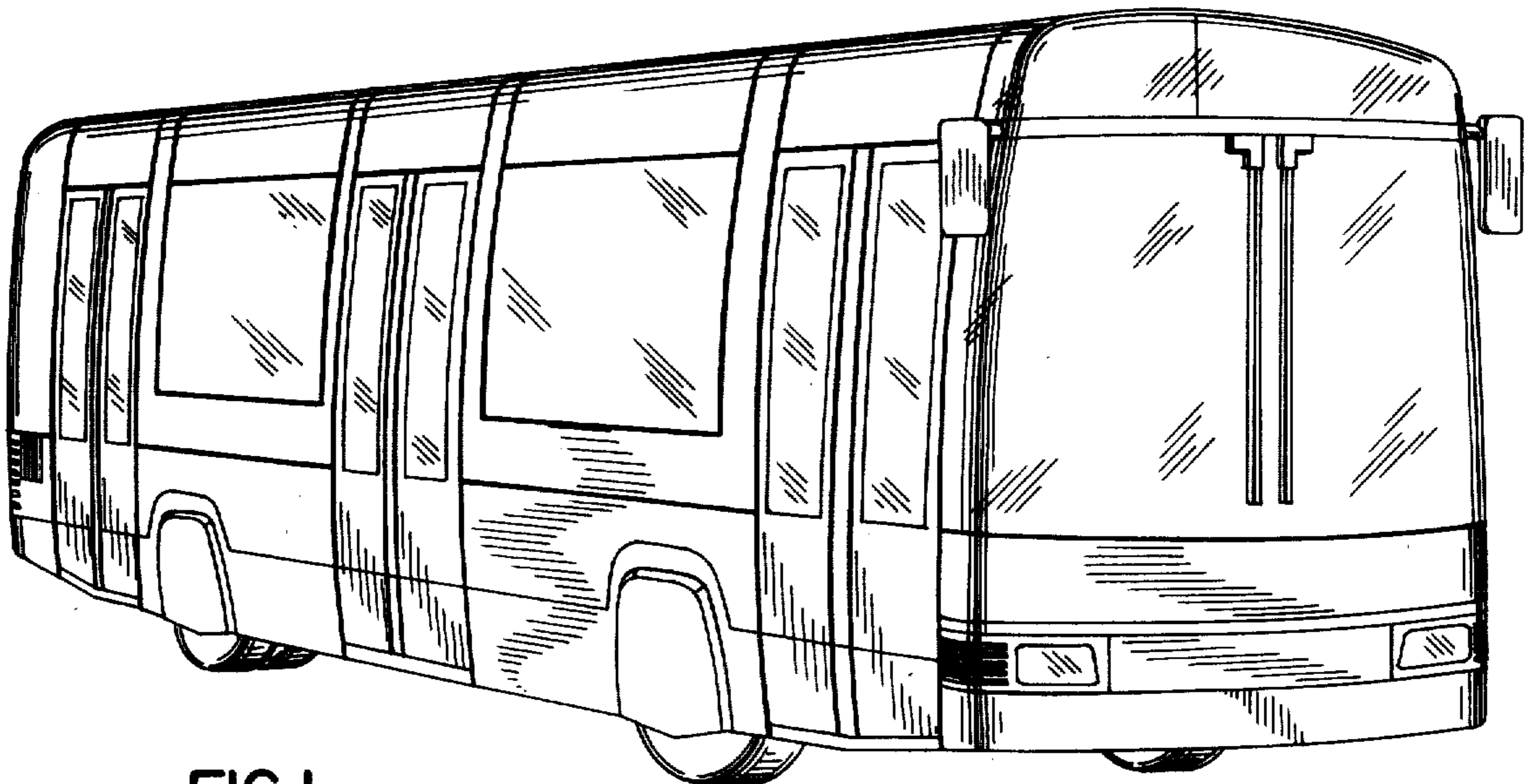

FIG.1



FIG.2

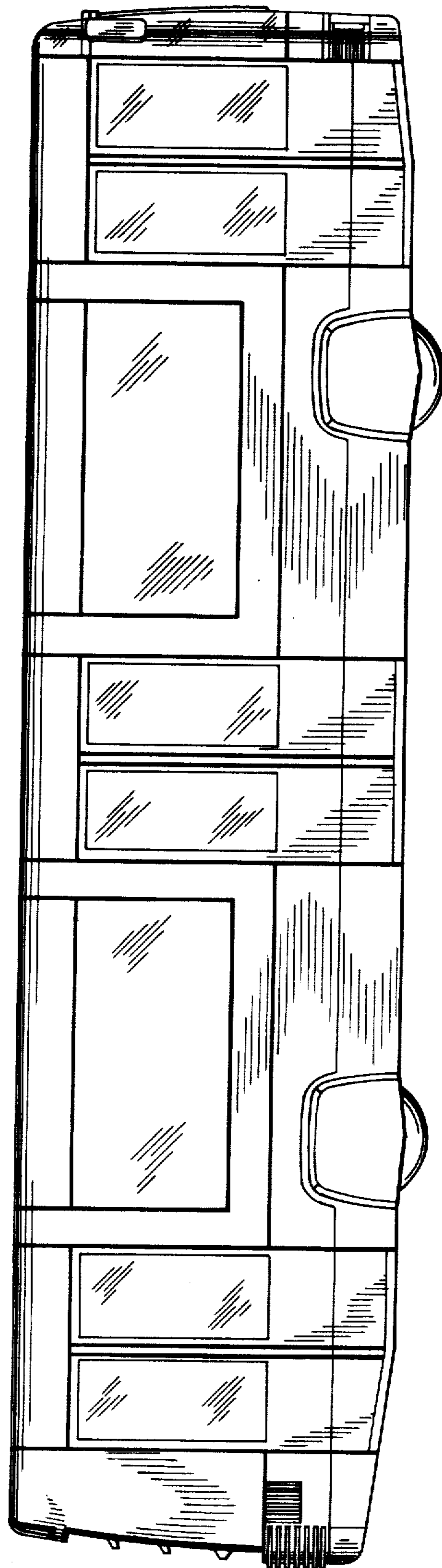

FIG.3

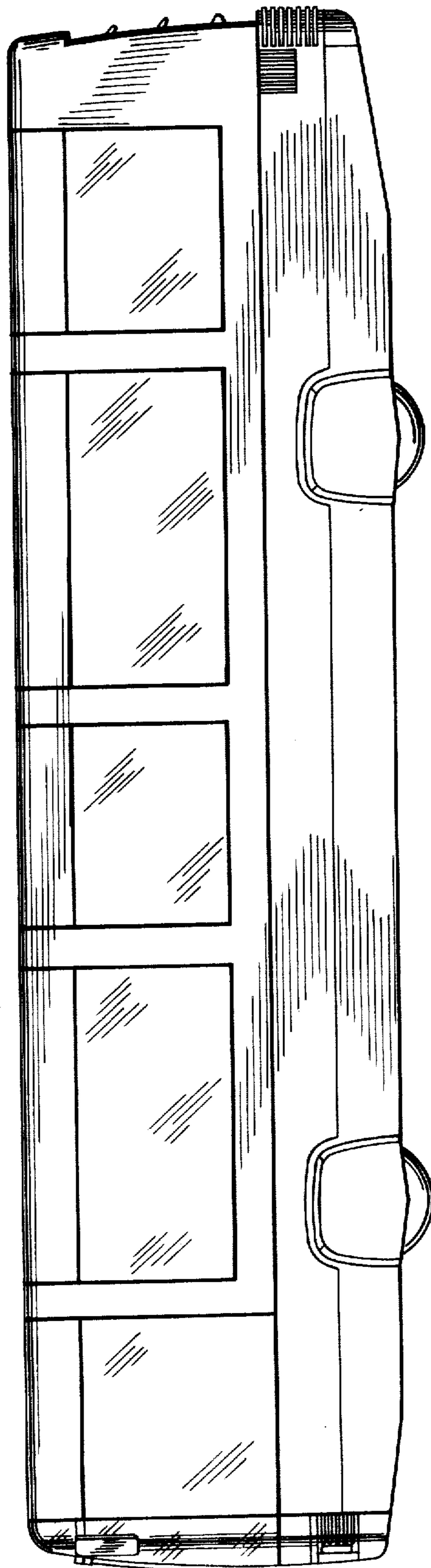

FIG. 4

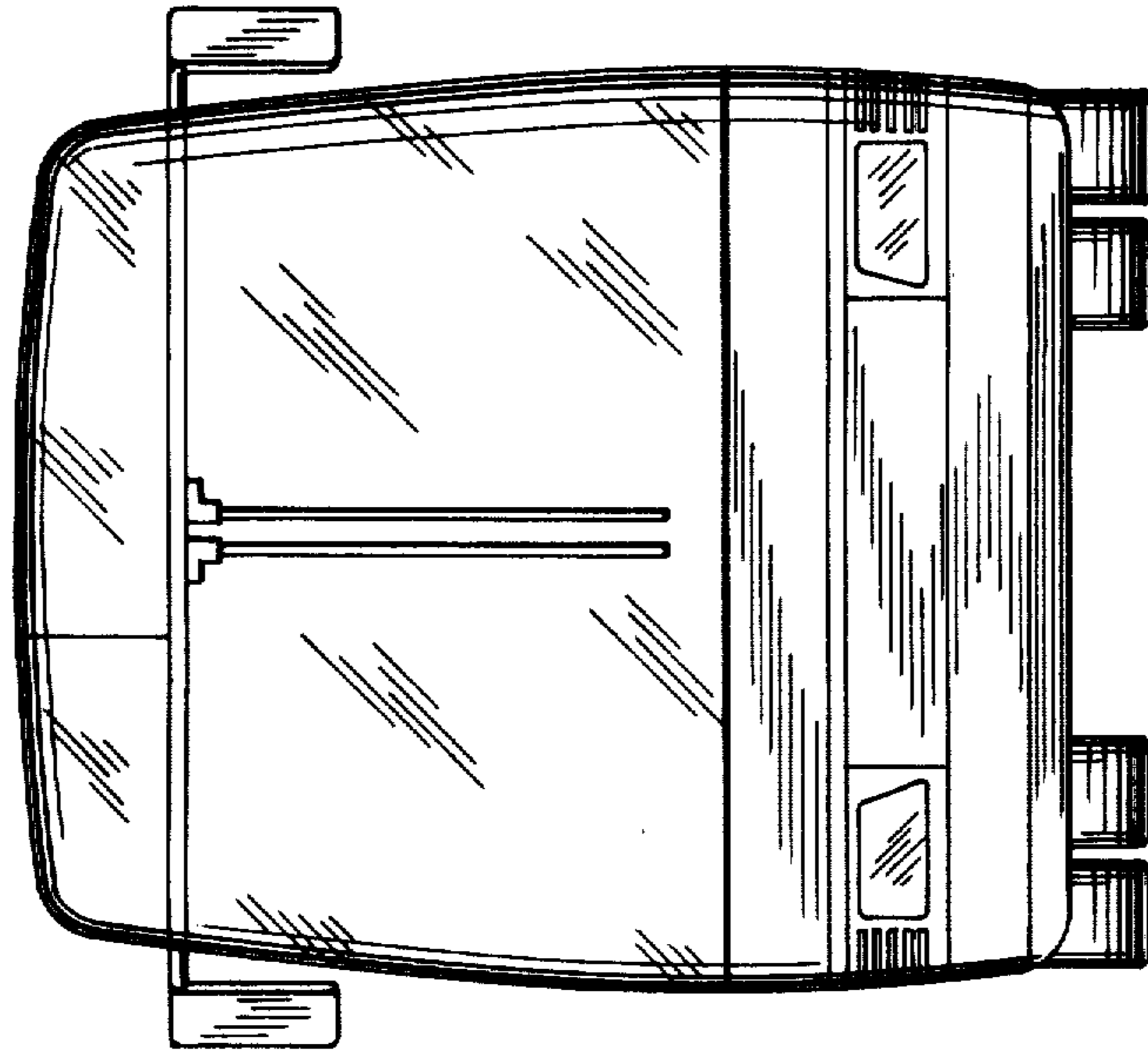

FIG.6

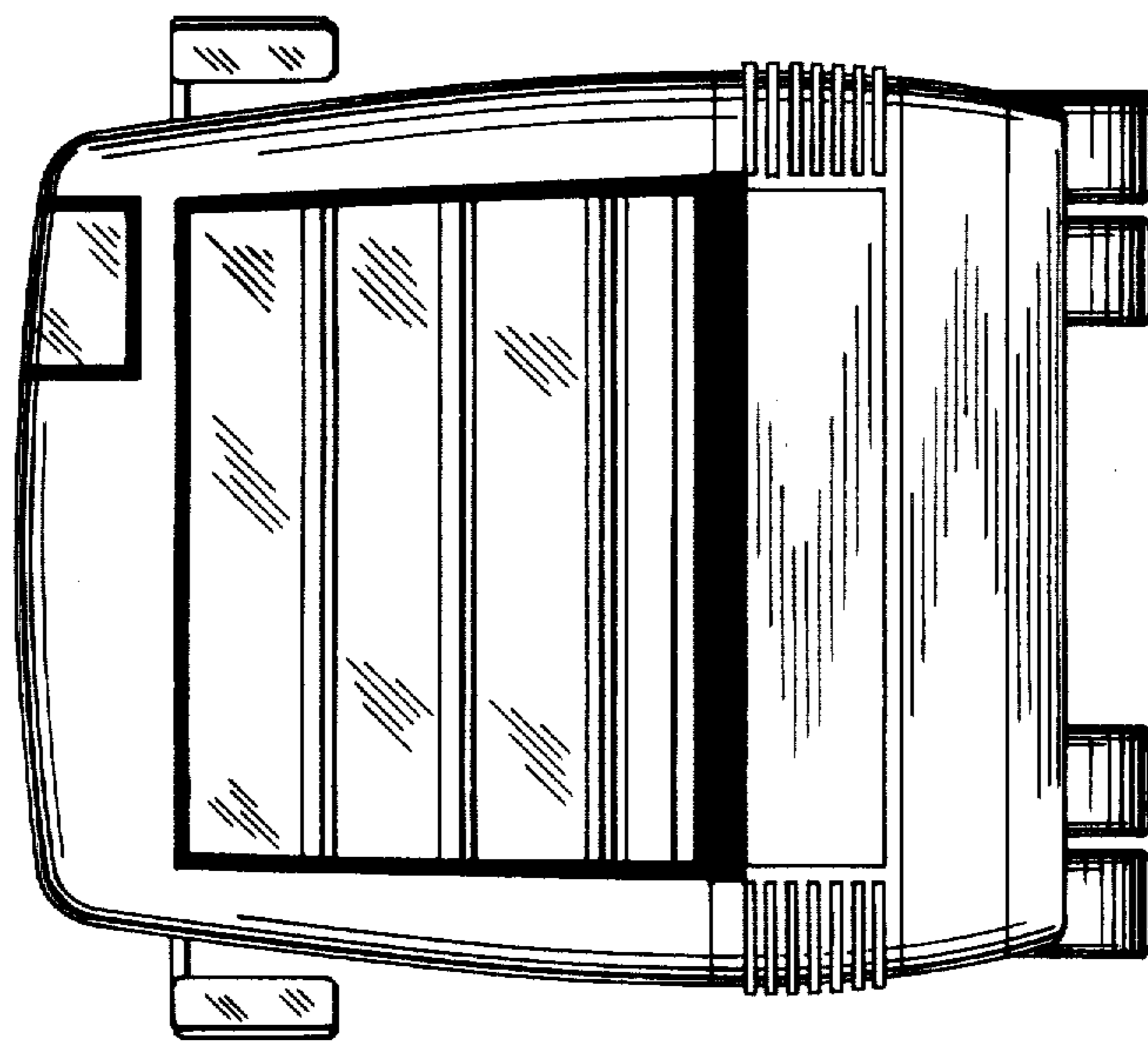

FIG.5