

[54] **SEAT ATTACHMENT FOR TRICYCLES**

[76] **Inventor:** James A. Mann, 25400 County Rd.
22 East, Elkhart, Ind. 46517

[**] **Term:** 14 Years

[21] **Appl. No.:** 188,961

[22] **Filed:** Sep. 19, 1980

[51] **Int. Cl.** D12-11

[52] **U.S. Cl.** D12/112

[58] **Field of Search** D12/112, 109; 280/202,
280/271, 281 B, 282

[56]

References Cited

U.S. PATENT DOCUMENTS

D. 149,193 4/1948 Larralde D12/112
D. 254,968 5/1980 Moore et al. D12/112

Primary Examiner—James M. Gandy
Attorney, Agent, or Firm—Eugene C. Knoblock

[57]

CLAIM

The ornamental design for a seat attachment for tricycles, as shown and described.

DESCRIPTION

FIG. 1 is a front perspective view of a seat attachment for tricycles showing my new design.

FIG. 2 is a rear perspective view of the side opposite that shown in FIG. 1.

The broken lines in the drawing are for illustrative purposes only.

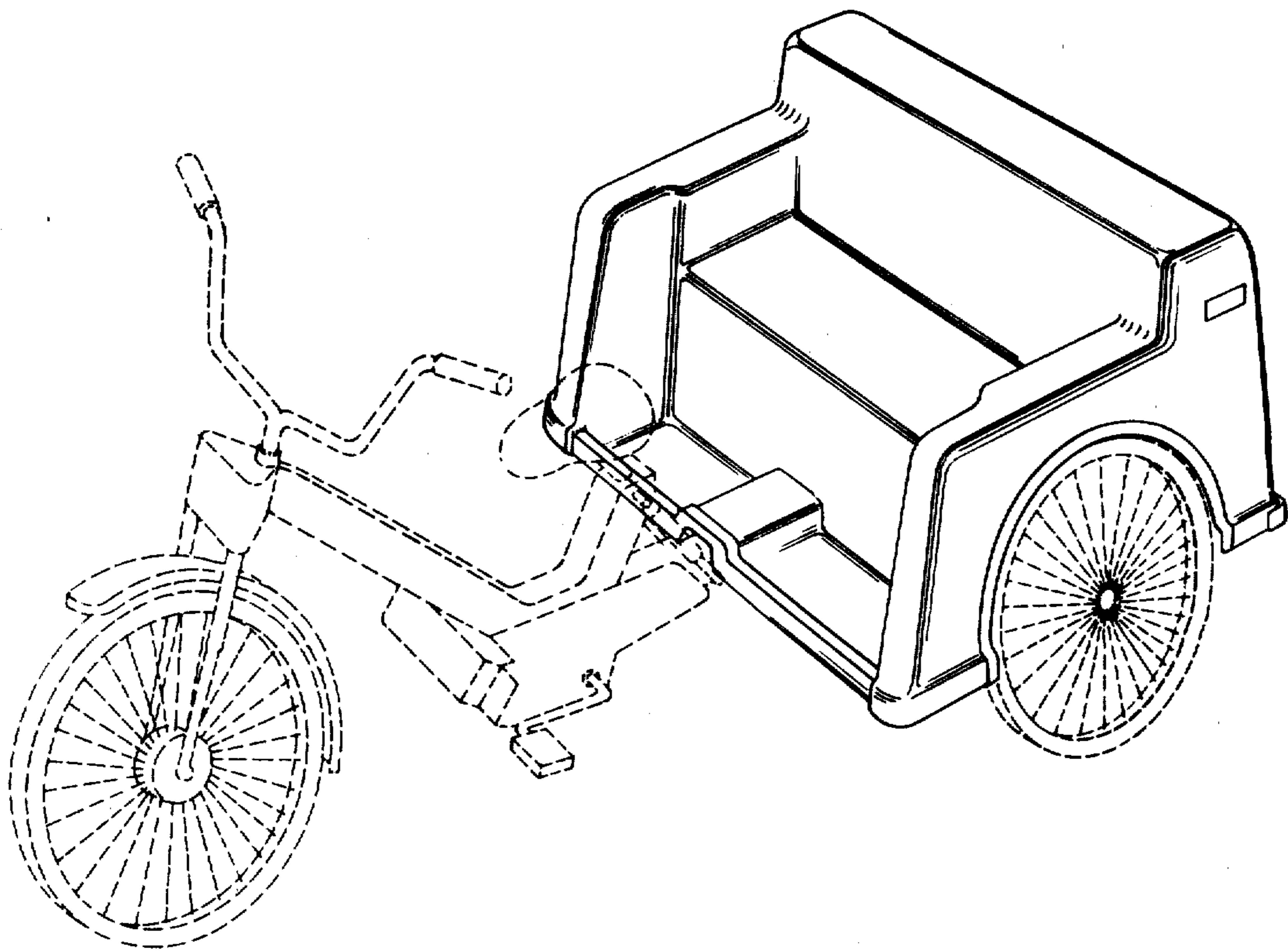

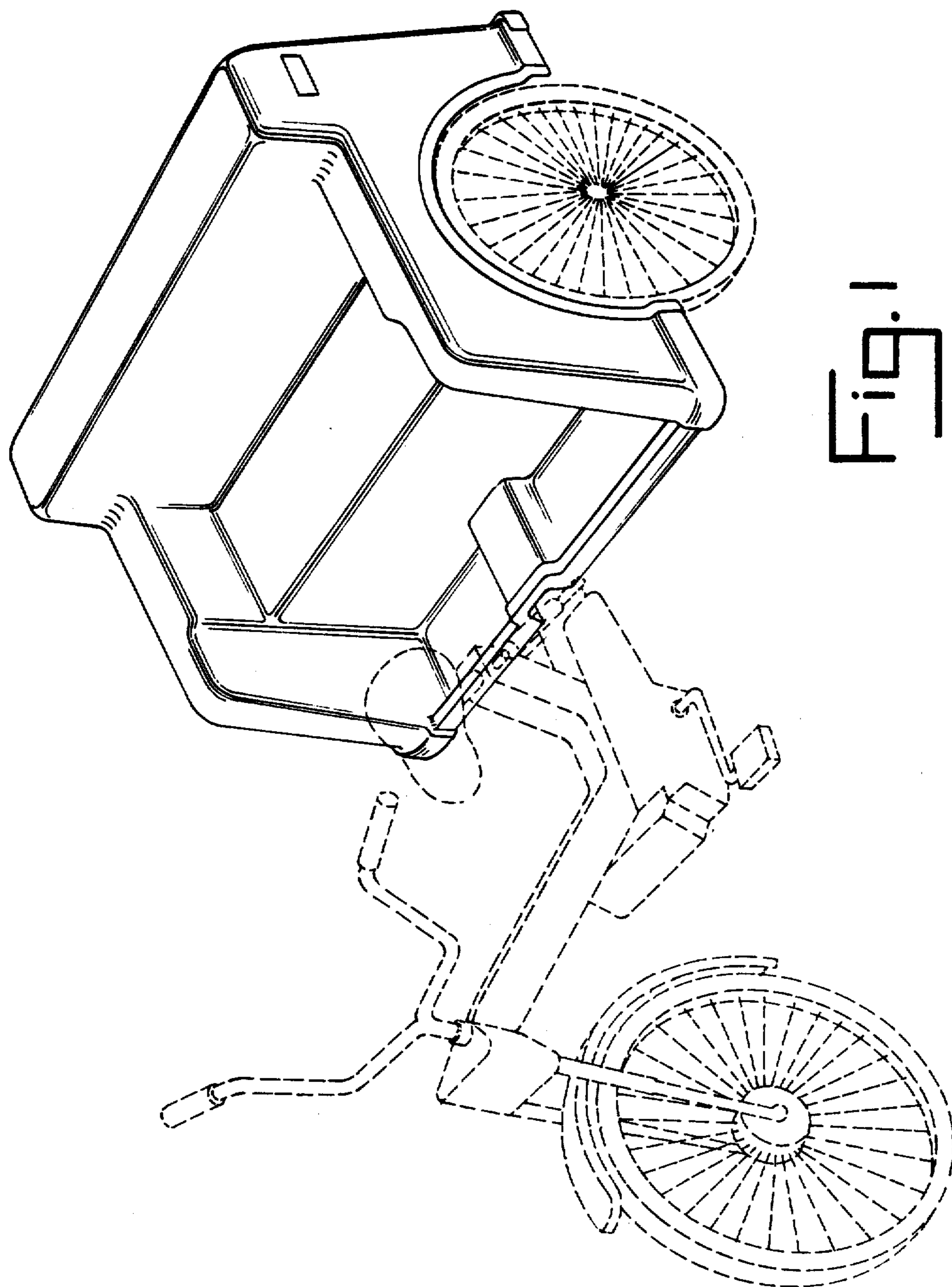

Fig. 1

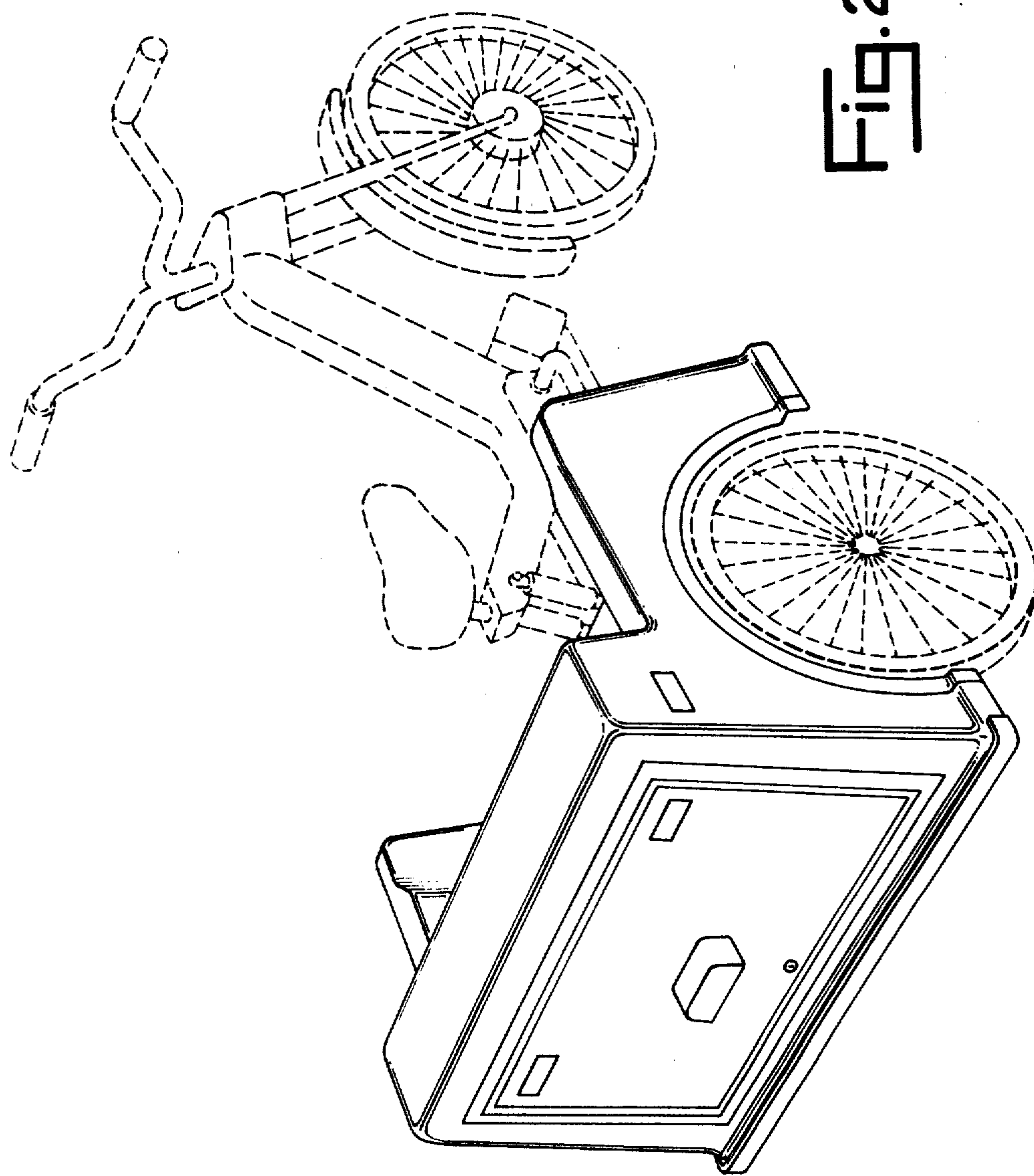

Fig. 2