

[54] **AIR CUSHION VEHICLE**

[75] **Inventor:** Daniel G. W. Turner, Romsey,
England

[73] **Assignee:** Phoenix Hovercraft Corp., Houston,
Tex.

[**] **Term:** 14 Years

[21] **Appl. No.:** 197,427

[22] **Filed:** Oct. 16, 1980

[30] **Foreign Application Priority Data**

Apr. 19, 1980 [GB] United Kingdom 994561/80

[51] **Int. Cl.** D12-14
[52] **U.S. Cl.** D12/5
[58] **Field of Search** D12/5; 180/127, 121,
180/116, 126

[56] **References Cited**

U.S. PATENT DOCUMENTS

D. 248,029 5/1978 Hart et al. D12/5
D. 248,031 5/1978 Hart et al. D12/5
3,840,089 10/1974 Allison 180/116
3,908,784 9/1975 Blurton et al. 180/116

Primary Examiner—A. Hugo Word
Attorney, Agent, or Firm—Steele, Gould & Fried

[57] **CLAIM**

The ornamental design for an air cushion vehicle, as shown.

DESCRIPTION

FIG. 1 is a rear perspective view from above and one side of the vehicle, showing my new design, FIG. 2 is a front perspective view from above and other side of the vehicle, FIG. 3 is a side elevation of the vehicle, and FIG. 4 is an enlarged perspective view from below of the vehicle.

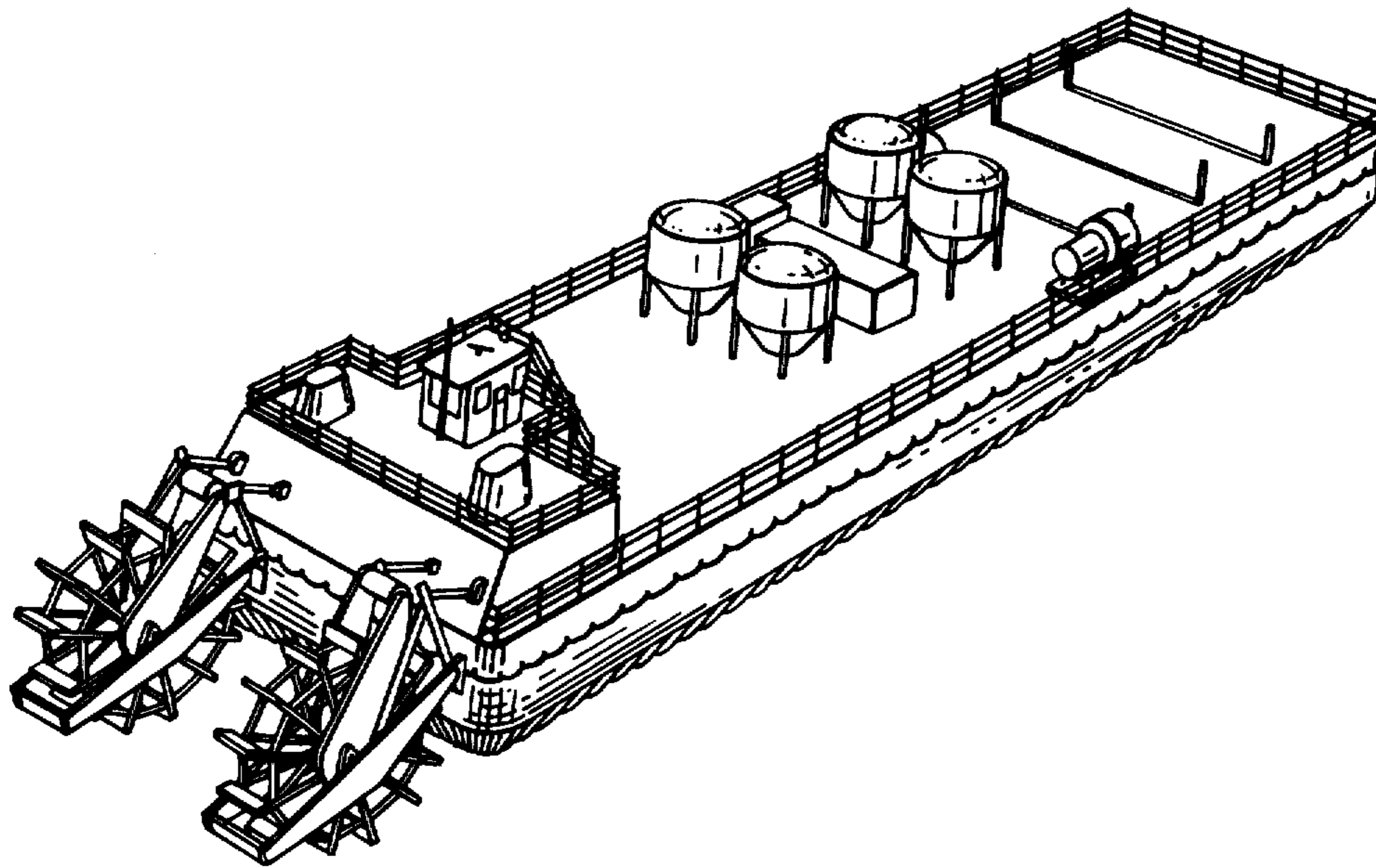

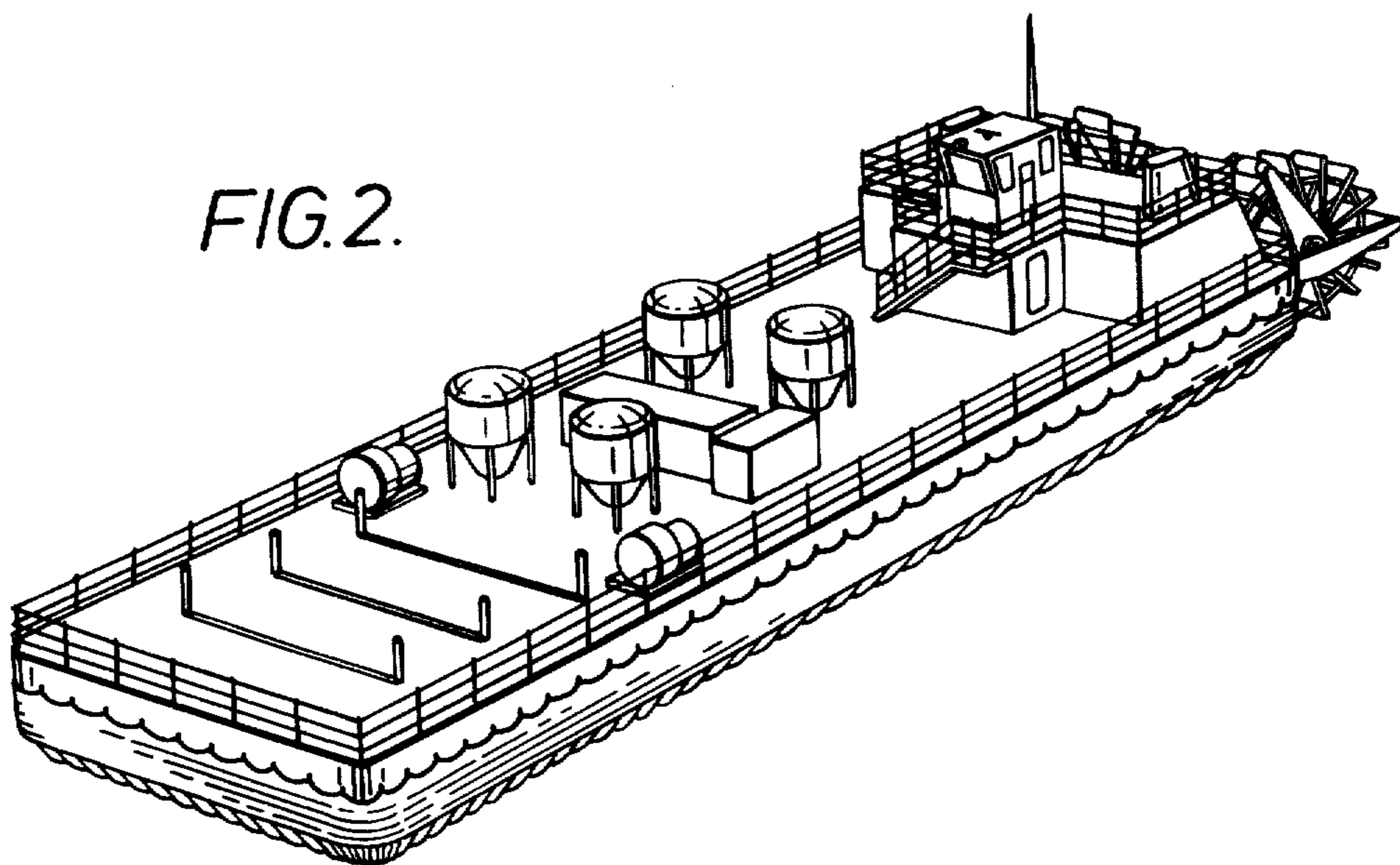
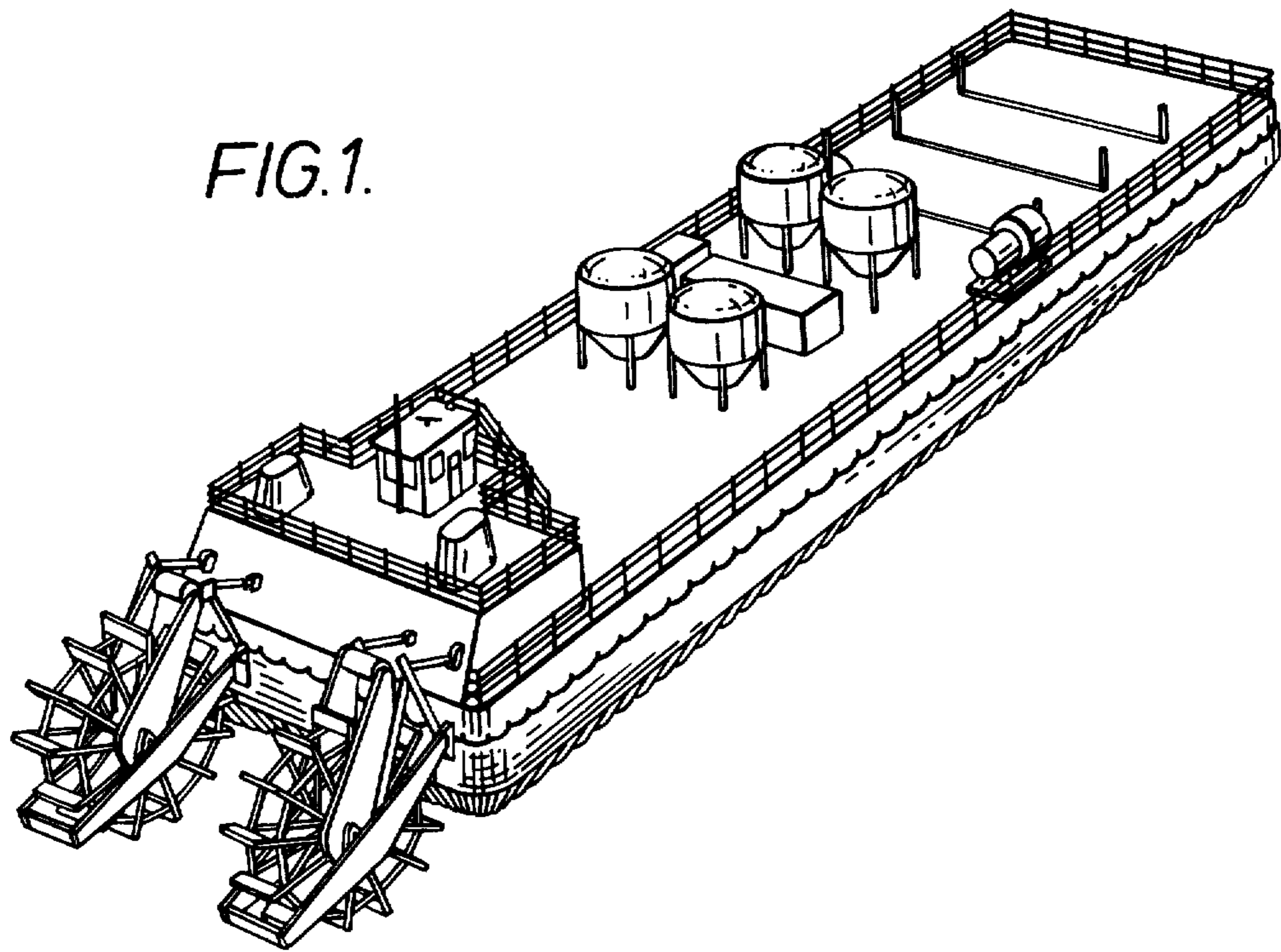

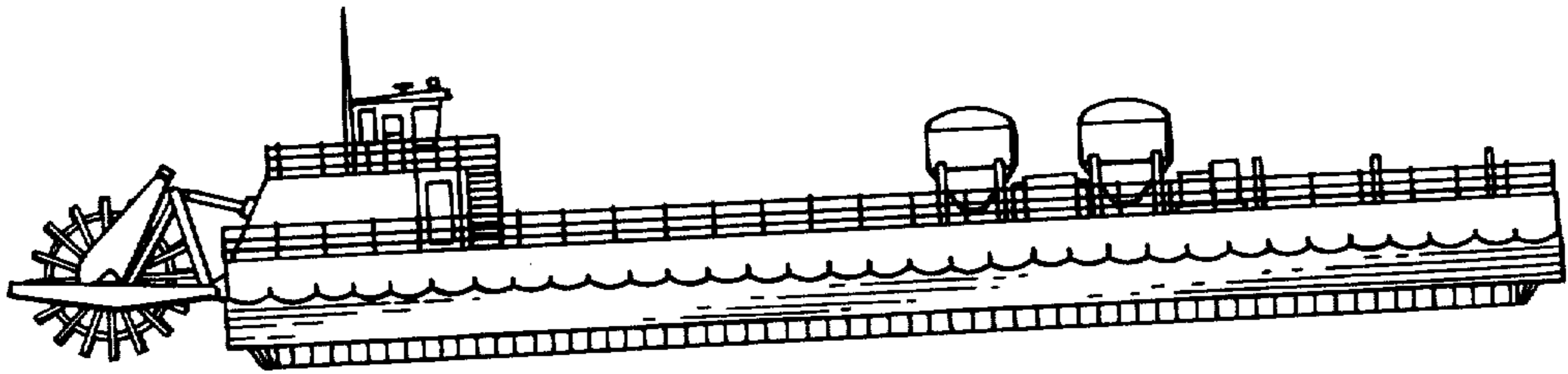

FIG. 3.

FIG. 4.

