

[54] **FRAME FOR A RACING CART**

[75] Inventors: **Dennis L. Greenhalgh; Dale R. Greenhalgh**, both of Vancouver, Wash.

[73] Assignee: **West Coast Marine Boat & Tug, Inc.**, Vancouver, Wash.

[**] Term: **14 Years**

[21] Appl. No.: **197,141**

[22] Filed: **Oct. 14, 1980**

[51] Int. Cl. **D12-08**

[52] U.S. Cl. **D12/88**

[58] Field of Search **D12/88; D21/76, 71, D21/78; 280/87.01, 781, 798; 296/15, 205**

[56] **References Cited**

U.S. PATENT DOCUMENTS

D. 243,627 3/1977 Clower D12/88

OTHER PUBLICATIONS

Design News, 4/21/75, p. 22, Dune-Buggy Frame.

Primary Examiner—James M. Gandy
Attorney, Agent, or Firm—Klarquist, Sparkman, Campbell, Leigh, Winston & Dellett

[57] **CLAIM**

The ornamental design for a frame for a racing cart, as shown and described.

DESCRIPTION

FIG. 1 is a perspective view of a frame for a racing cart as viewed toward the front, top and one side thereof, showing our new design;

FIG. 2 is a perspective view, as viewed toward the back and opposite side thereof; and

FIG. 3 is a bottom perspective view thereof.

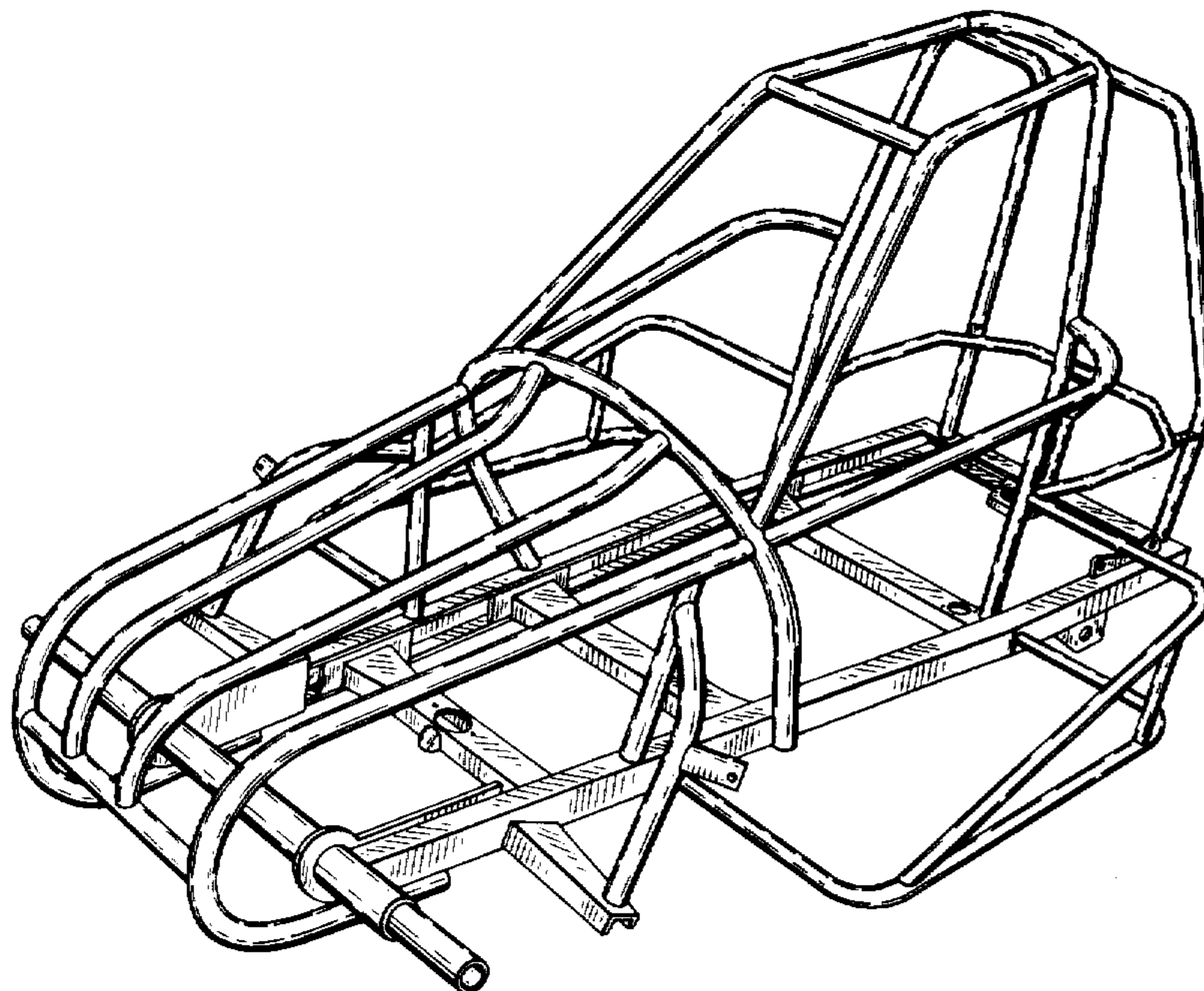

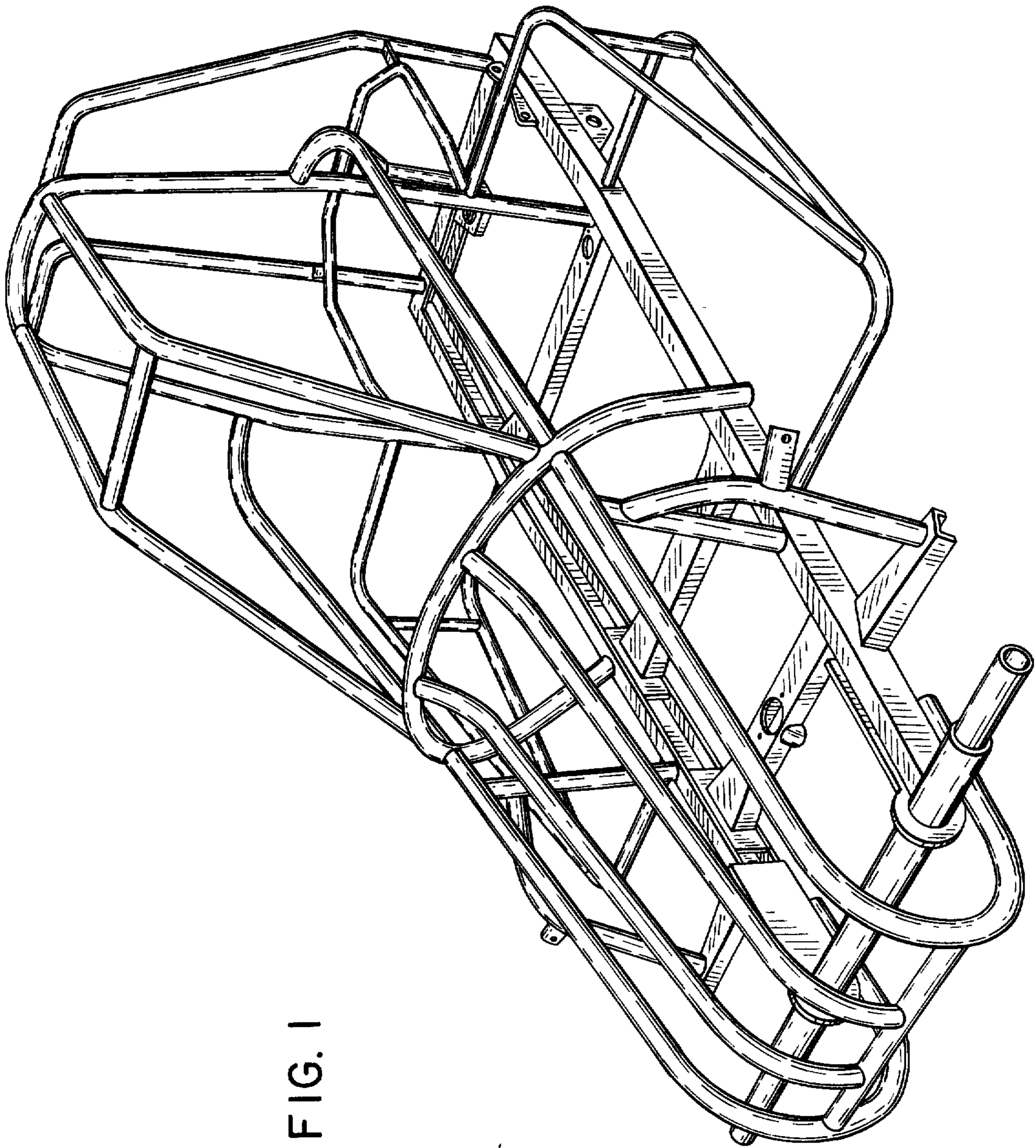

FIG. 1

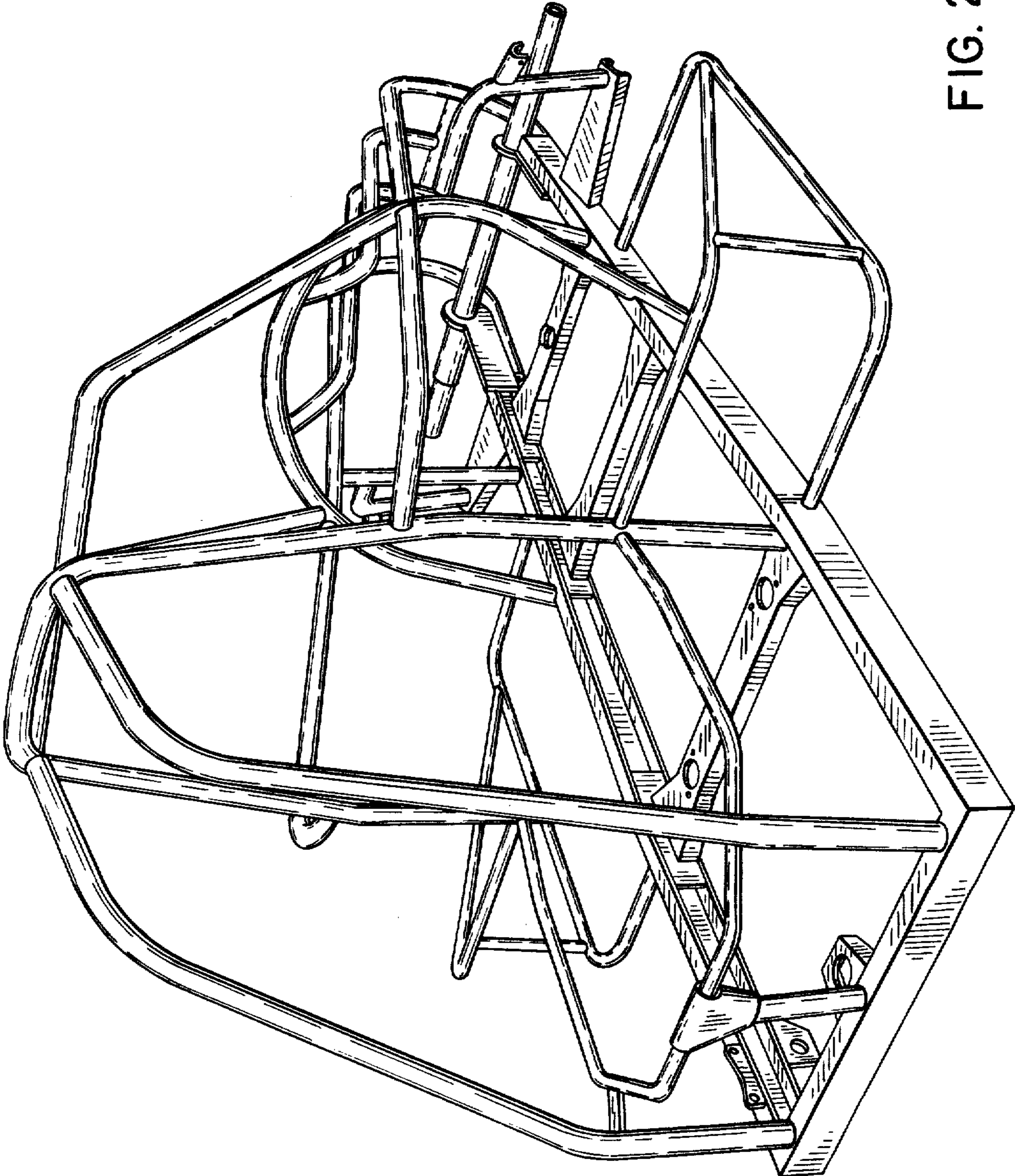

FIG. 2

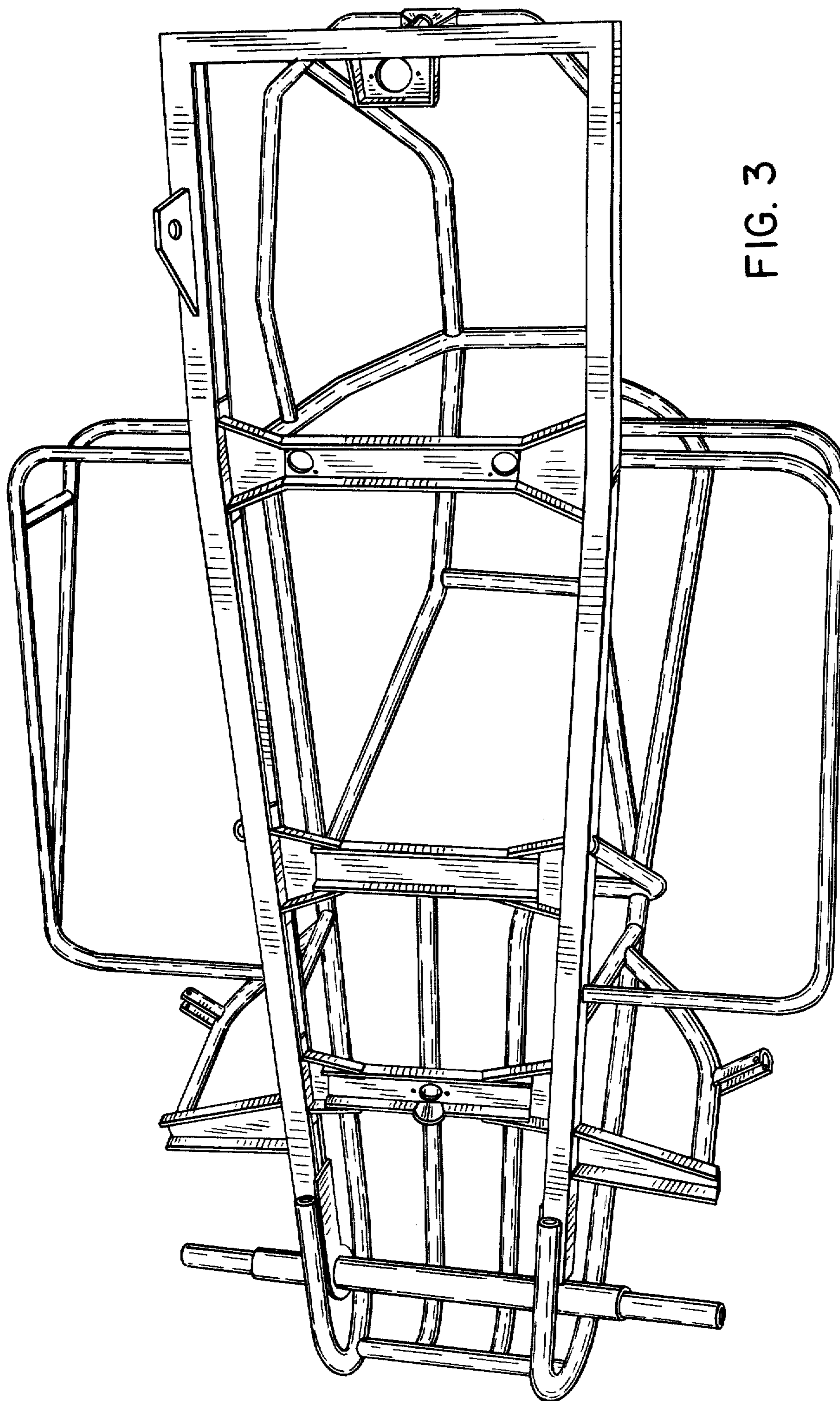

FIG. 3