

[54] COMBINED SKI AND BOOT CARRIER

[76] Inventors: Joseph A. Spollino, 1453 N. Cleveland Ave., Orange, Calif. 92667; Ronald A. Spollino, 4255 S. Tamarus St. #109, Las Vegas, Nev. 89109

[**] Term: 14 Years

[21] Appl. No.: 203,262

[22] Filed: Nov. 3, 1980

[51] Int. Cl. D3-99
[52] U.S. Cl. D3/36
[58] Field of Search D3/30.1, 36-38; D8/312-314; 294/146, 149, 150, 153-157, 168-171; 224/917; 211/60 SK

[56]

References Cited

U.S. PATENT DOCUMENTS

D. 256,520	8/1980	DiCarlo et al.	D3/36
2,448,894	9/1948	Lans	294/171
3,257,054	6/1966	Miesel	294/149
4,002,277	1/1977	Westerholm	294/154

Primary Examiner—George P. Word
Attorney, Agent, or Firm—Grover A. Frater

[57]

CLAIM

The ornamental design for a combined ski and boot carrier, substantially as shown.

DESCRIPTION

FIG. 1 is a top plan view of a combined ski and boot carrier showing our new design; FIG. 2 is a front elevational view thereof; FIG. 3 is a side elevational view thereof; FIG. 4 is a rear elevational view thereof; and FIG. 5 is a bottom plan view thereof.

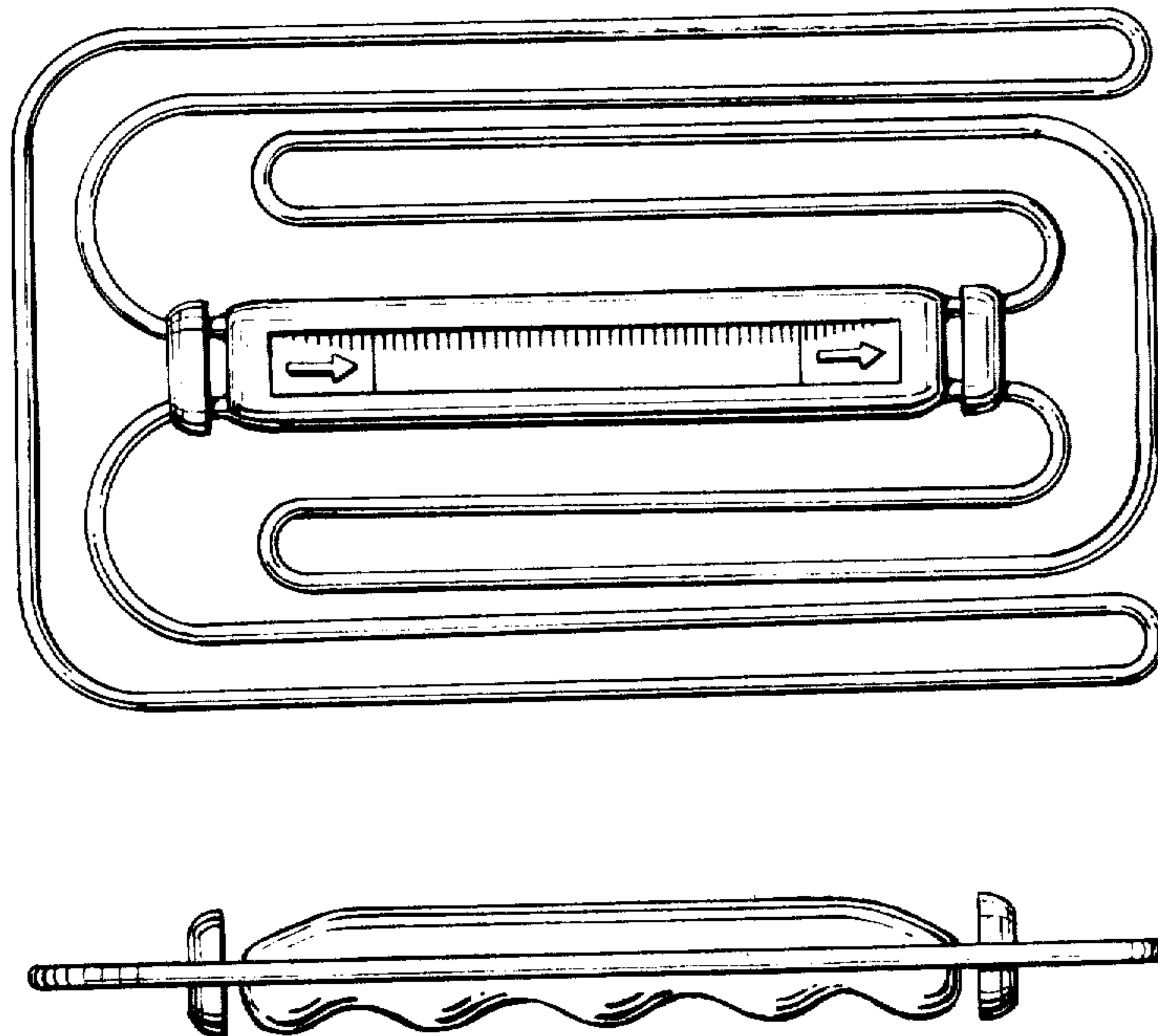

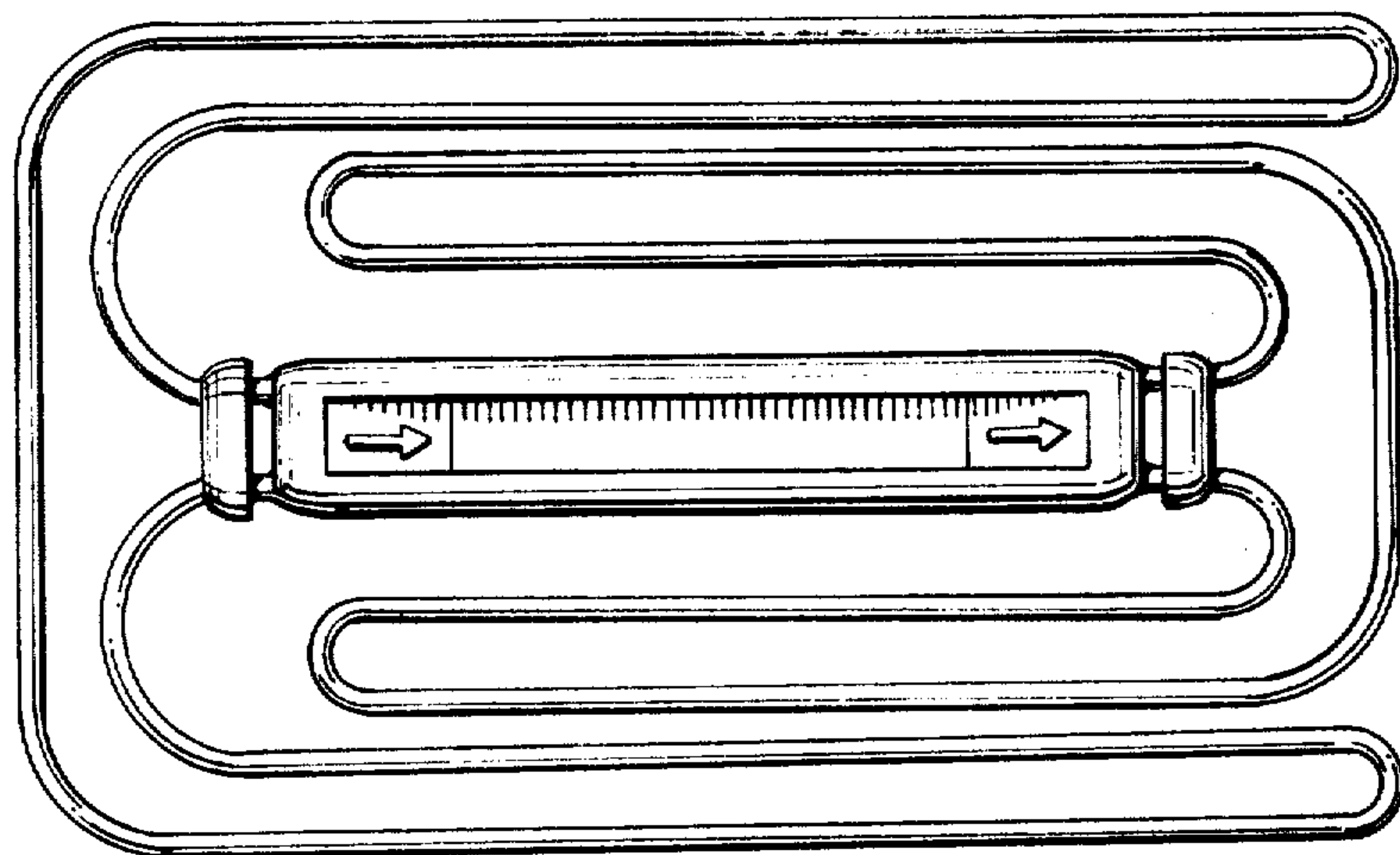

FIG. 1



FIG. 2

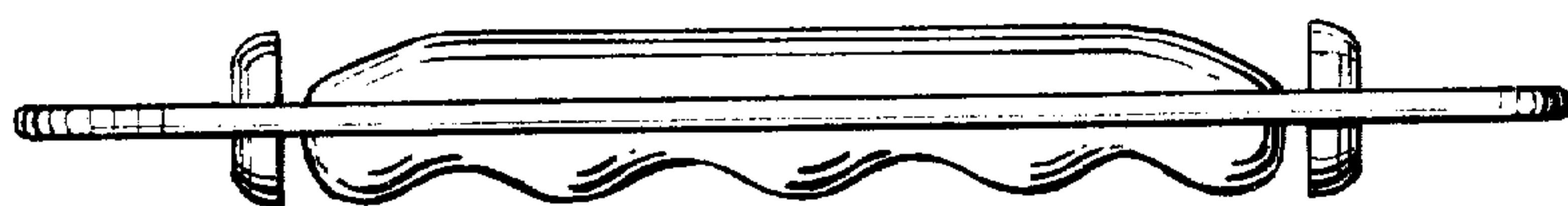

FIG. 3

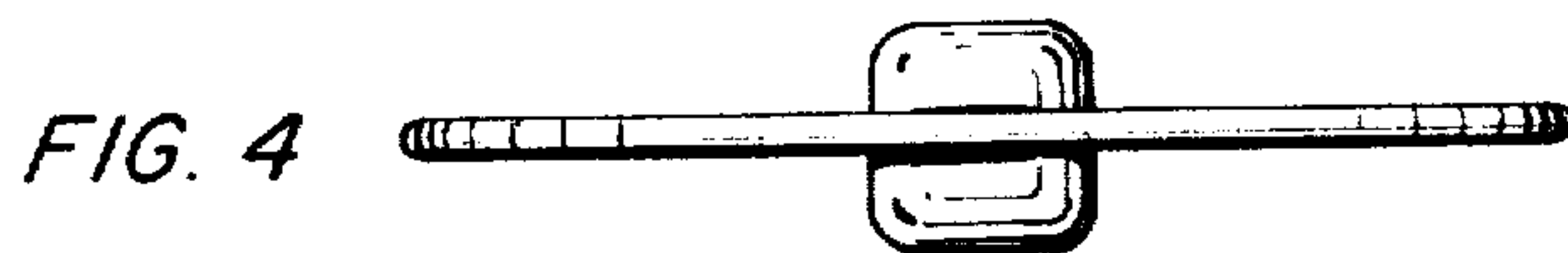

FIG. 4

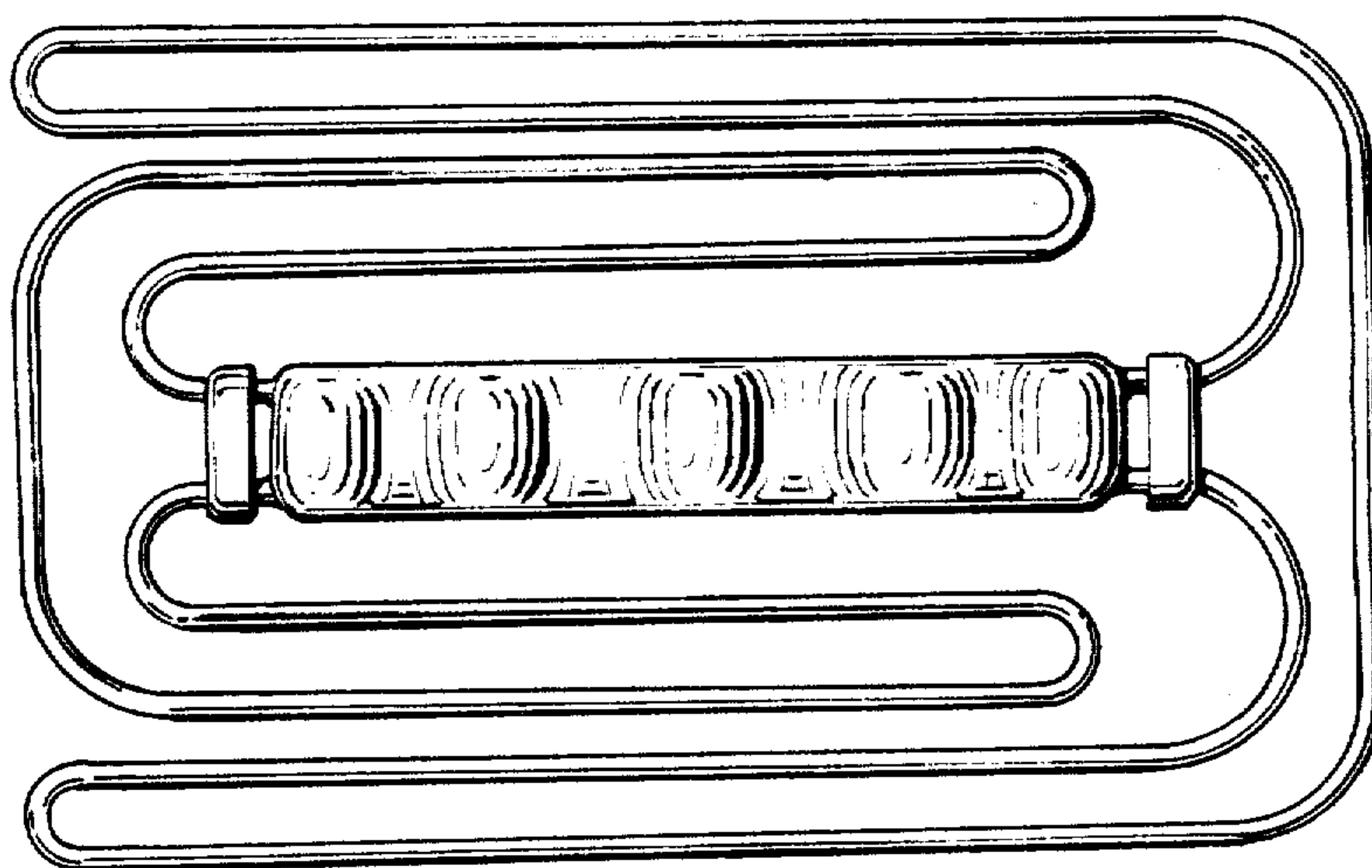

FIG. 5