

[54] ELECTRIC FAN FOR ENGINE COOLING

[76] Inventor: Roger Clemente, 1789 Vauxhill Rd., Union, N.J. 07083

[**] Term: 14 Years

[21] Appl. No.: 190,939

[22] Filed: Sep. 25, 1980

[51] Int. Cl. D23-04

[52] U.S. Cl. D23/158

[58] Field of Search D23/139-167; 123/41.12, 41.49, 41.65, 41.66; 416/244 R, 245 R; 417/423, 424

[56] References Cited

U.S. PATENT DOCUMENTS

- D. 187,699 4/1960 Van Rijn D23/158
- D. 231,355 4/1974 Papst D23/160

- 3,621,822 11/1971 Oster 123/41.12
- 4,257,554 3/1981 Willingham 123/41.12 X
- 4,329,946 5/1982 Longhouso 123/41.49

Primary Examiner—James R. Largen
Attorney, Agent, or Firm—Louis E. Marn; Elliot M. Olstein

[57] CLAIM

The ornamental design for an electric fan for engine cooling, substantially as shown.

DESCRIPTION

FIG. 1 is a front elevational view of an electric fan for engine cooling showing my new design; FIG. 2 is a rear elevational view thereof; FIG. 3 is a top plan view thereof; FIG. 4 is a bottom plan view thereof; FIG. 5 is a left side elevational view thereof; and FIG. 6 is a right side elevational view thereof.

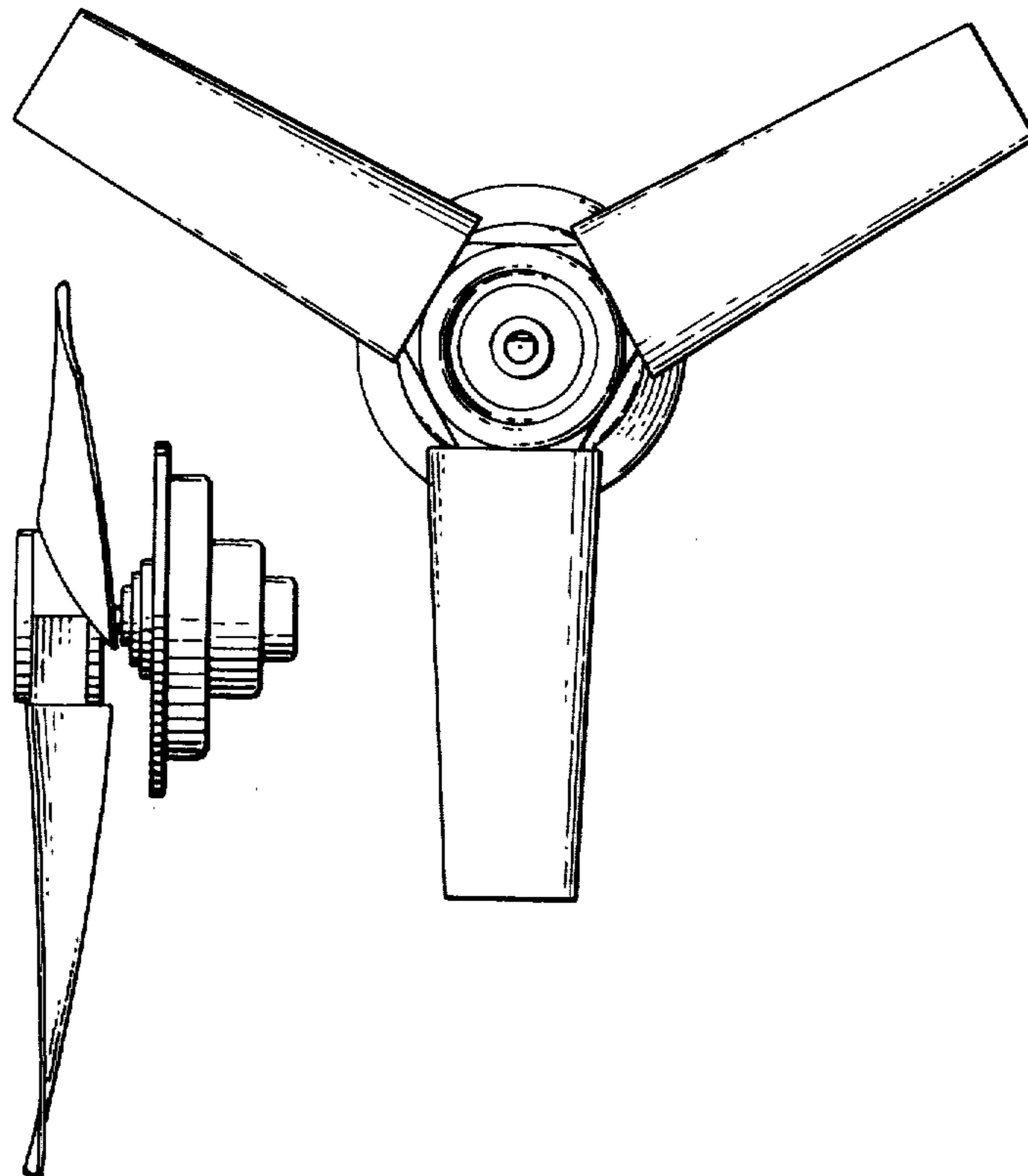

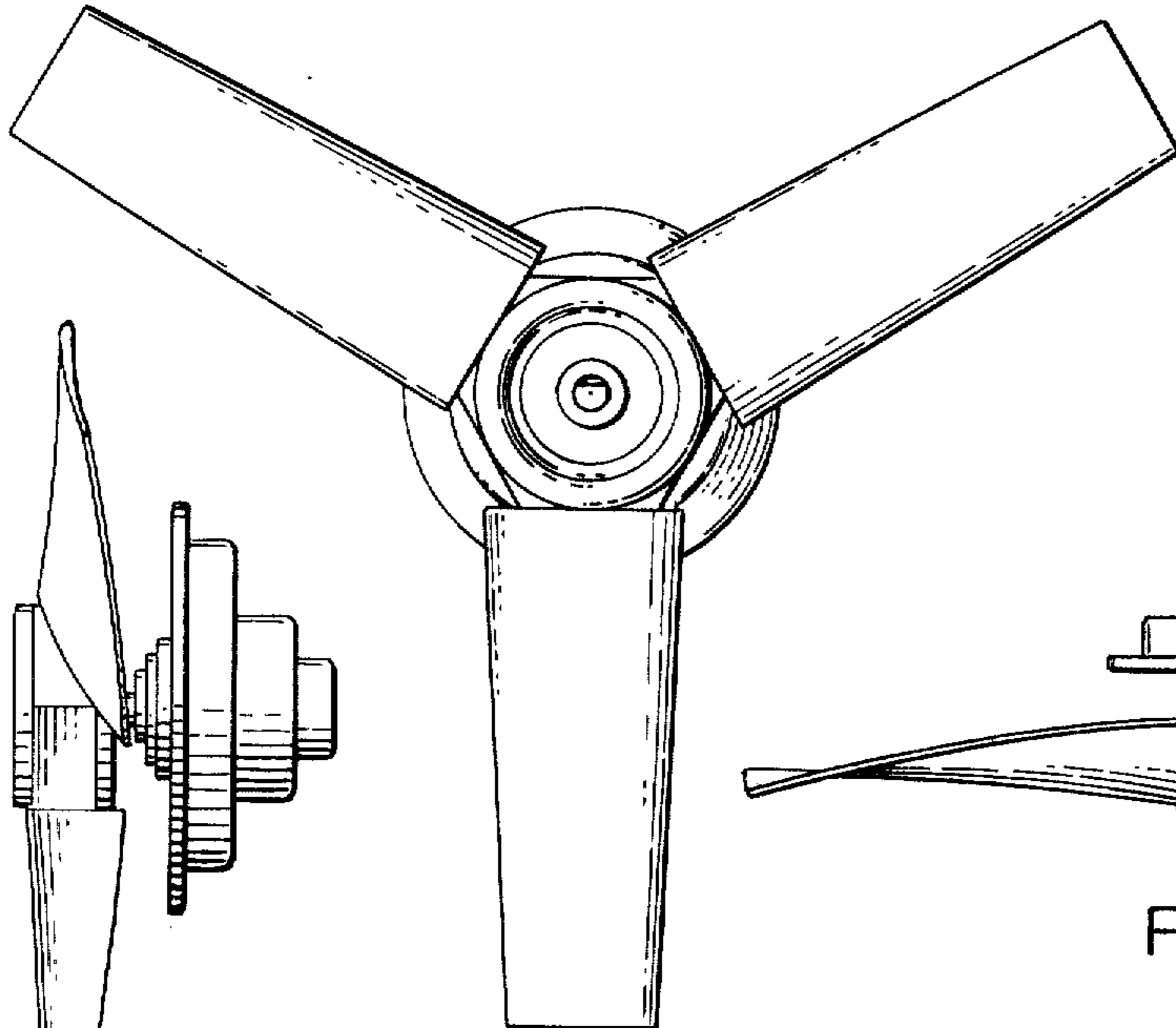

FIG. 1

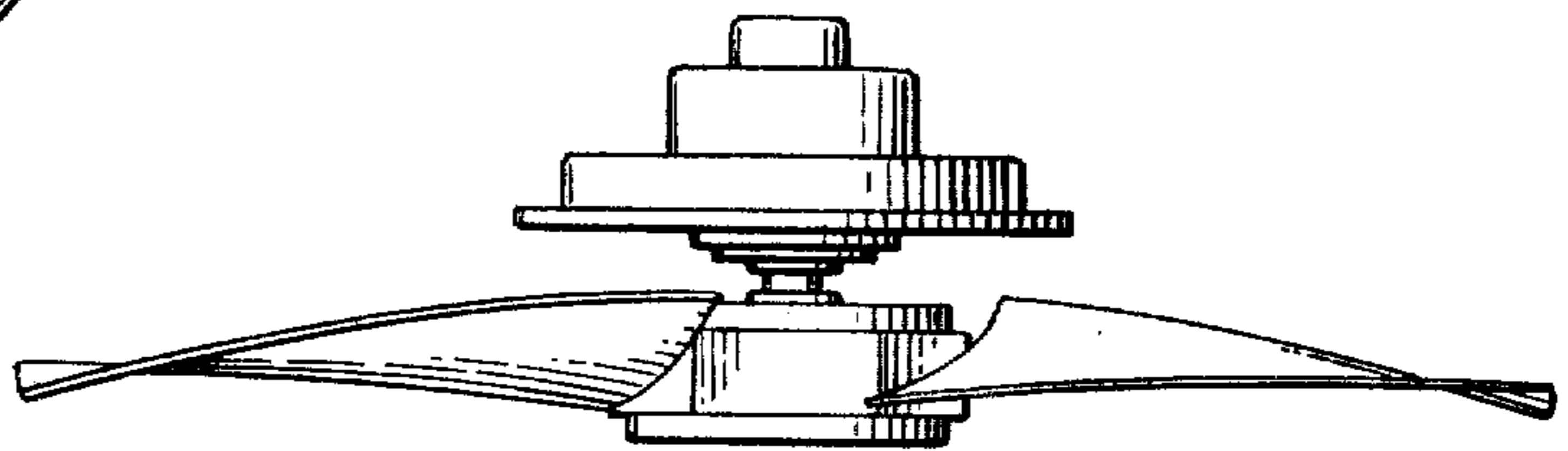

FIG. 3

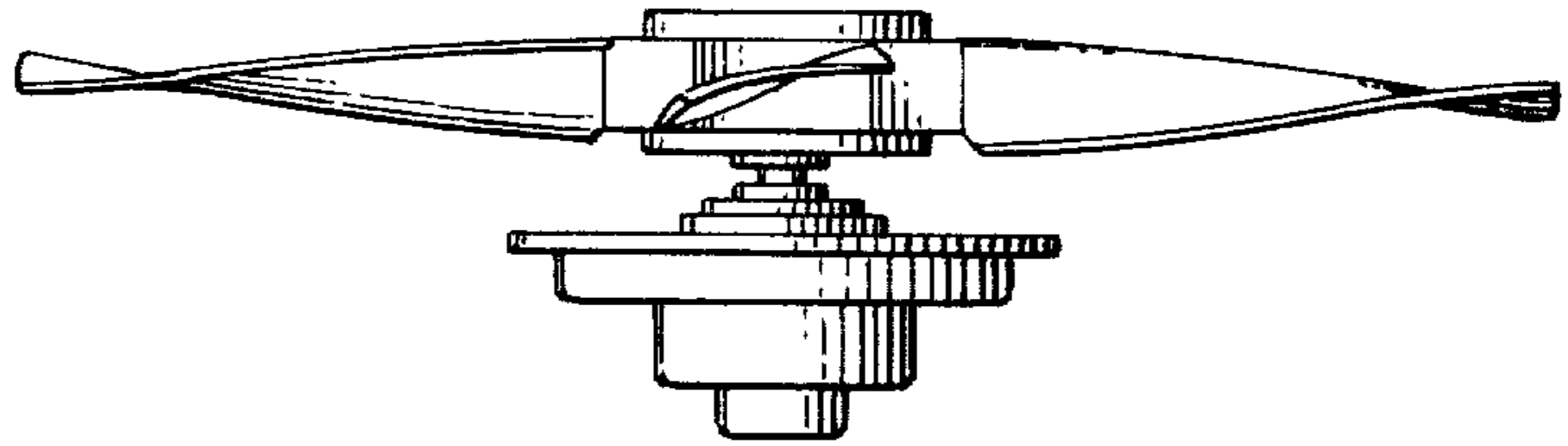

FIG. 4

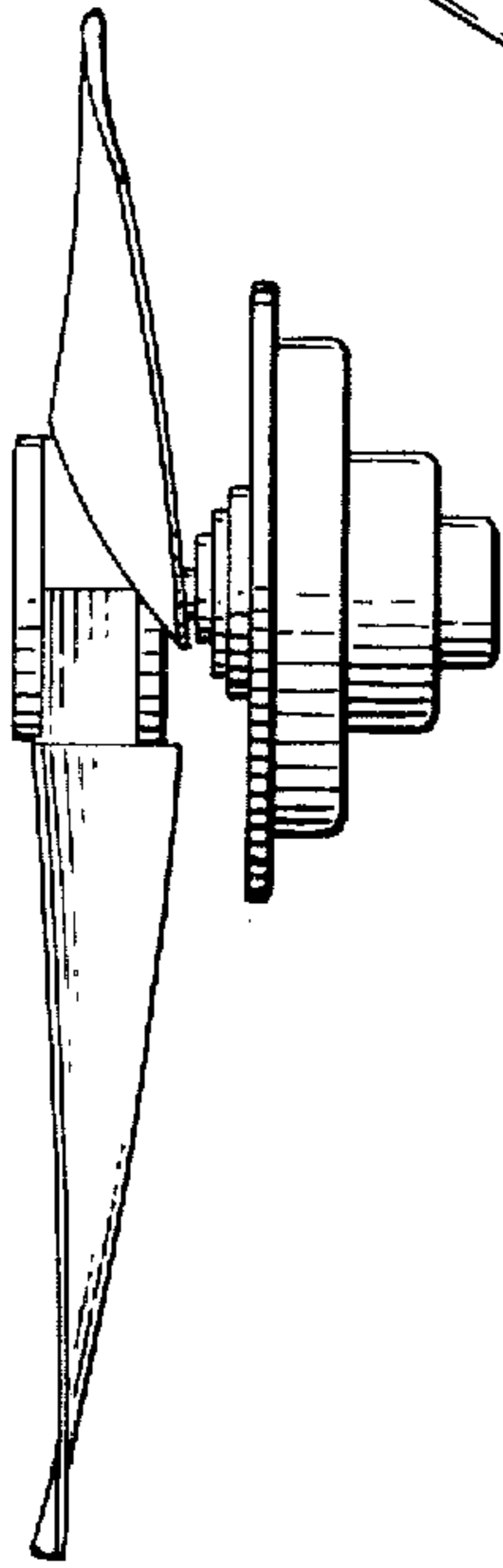

FIG. 6

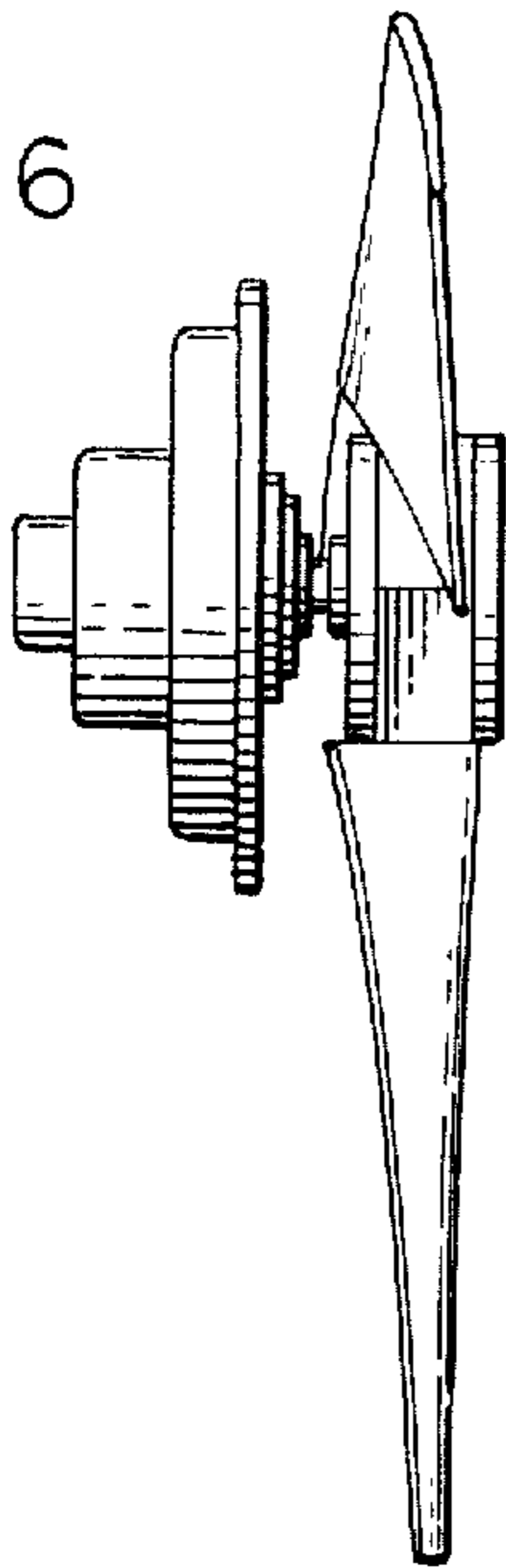

FIG. 5

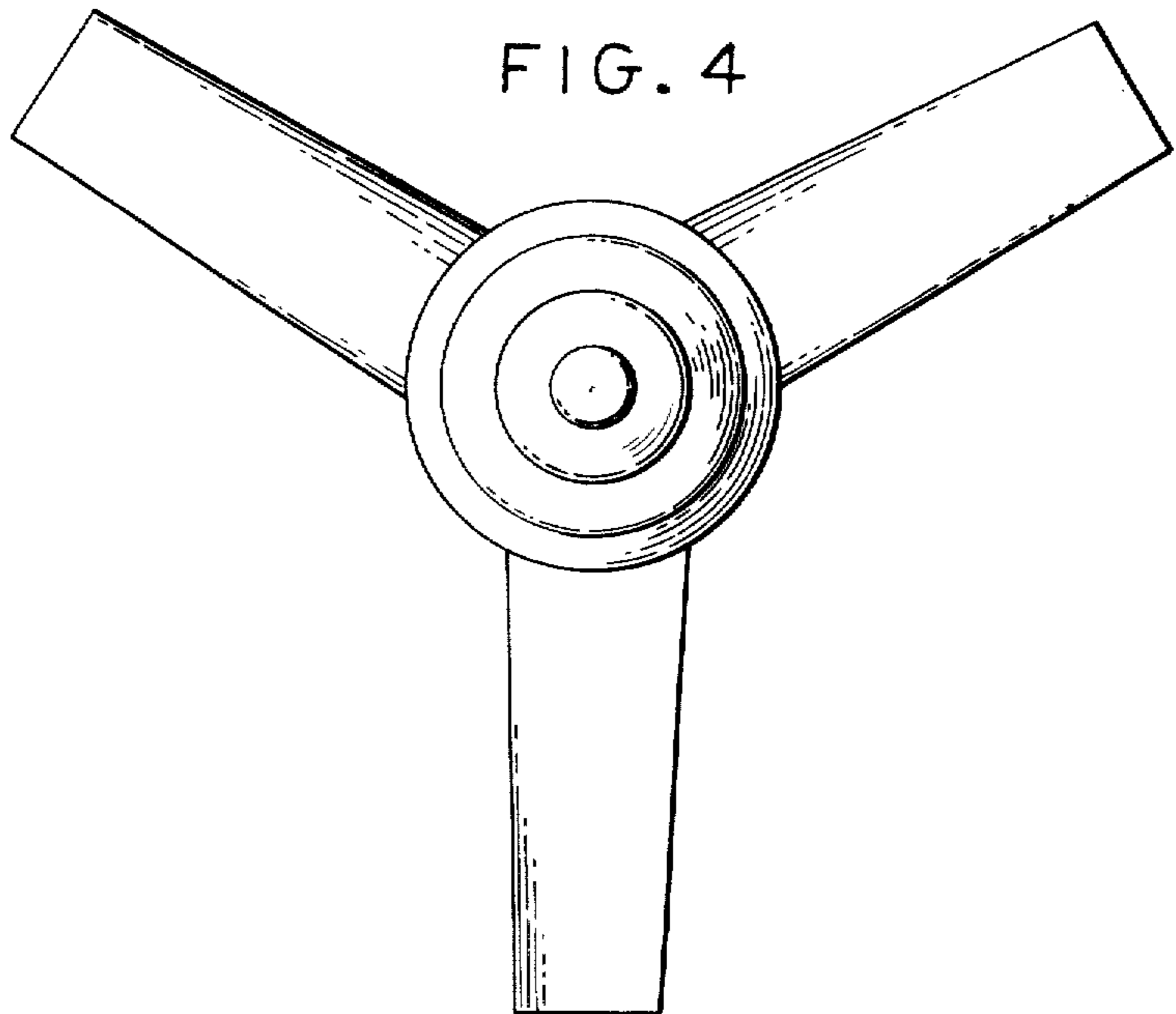

FIG. 2