

[54] ROTOR ELEMENT COMPONENT FOR A COAL CRUSHER

[75] Inventor: Wilbur W. Bagby, Birmingham, Ala.

[73] Assignee: Bagby Engineering Co., Birmingham, Ala.

[\*\*] Term: 14 Years

[21] Appl. No.: 186,719

[22] Filed: Sep. 11, 1980

[51] Int. Cl. .... D15-99

[52] U.S. Cl. .... D15/123; D15/138

[58] Field of Search ..... D15/122, 123, 138-139, D15/147, 199; 241/191

[56] References Cited

U.S. PATENT DOCUMENTS

744,382	11/1903	Moor	241/191
2,352,127	6/1944	Sheldon	241/191
2,417,184	3/1947	Wagner et al.	241/191

2,585,943	2/1952	Kessler	241/191
2,965,321	12/1960	Koontz	241/191

Primary Examiner—B. J. Bullock  
Attorney, Agent, or Firm—Woodford R. Thompson, Jr.

[57] CLAIM

The ornamental design for a rotor element component for a coal crusher, as shown and described.

DESCRIPTION

FIG. 1 is a perspective view of the rotor element component for coal crusher showing my new design, the other component being shown in broken lines for illustrative purposes only;

FIG. 2 is a front elevational view thereof;

FIG. 3 is a rear elevational view thereof;

FIG. 4 is an end elevational view looking from the left of FIG. 2;

FIG. 5 is an end elevational view looking from the right of FIG. 4;

FIG. 6 is a top plan view; and

FIG. 7 is a bottom plan view.

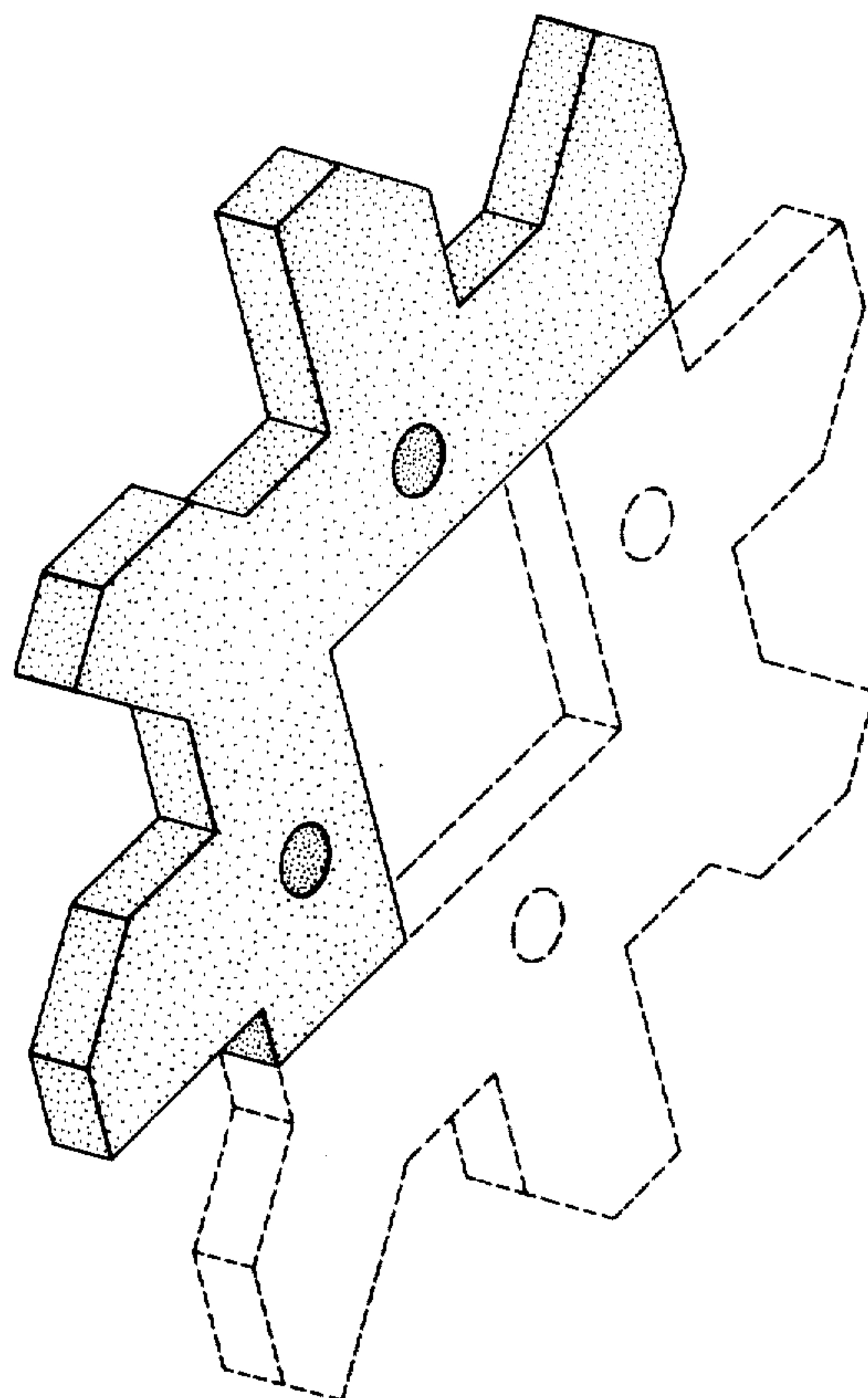

FIG. 1

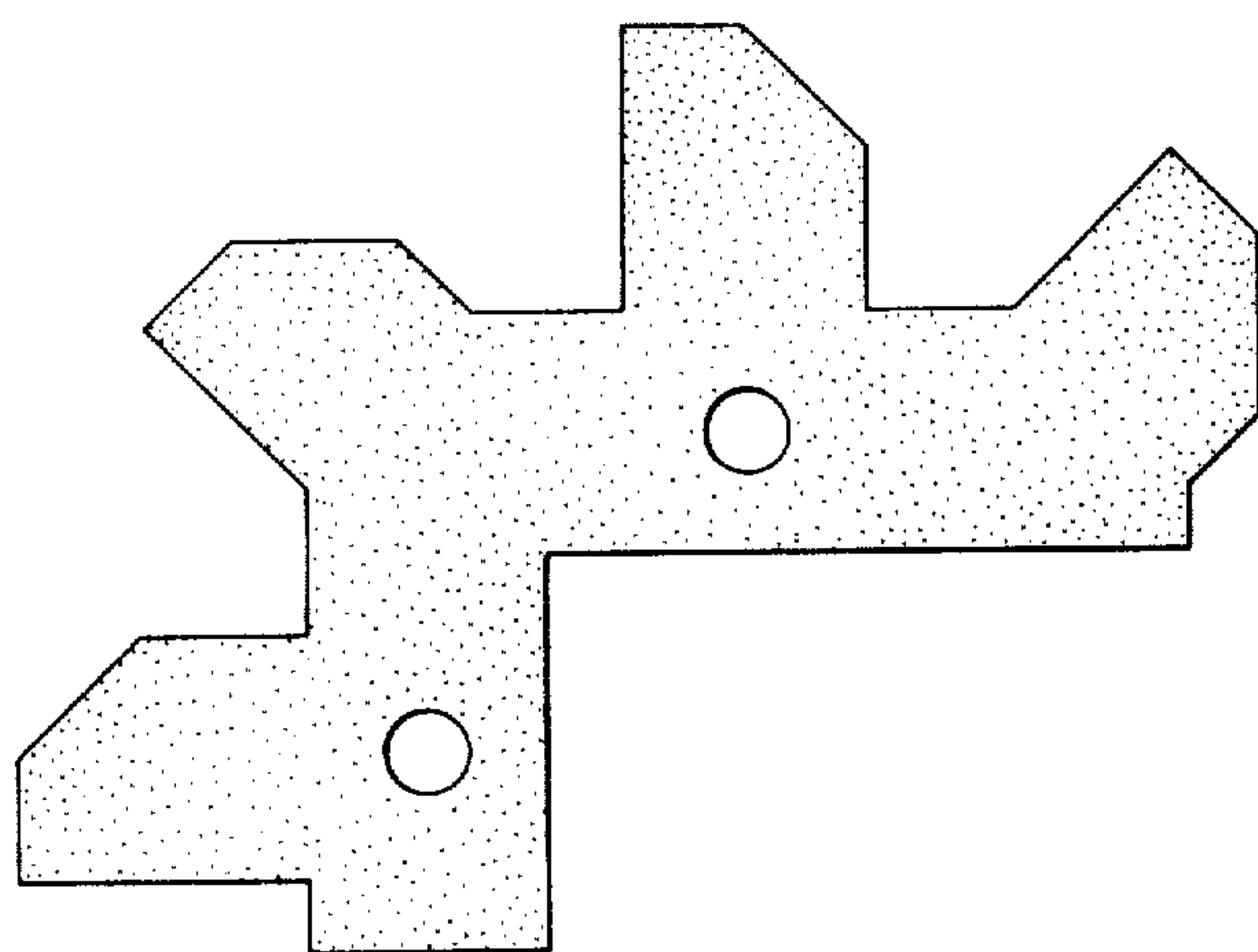
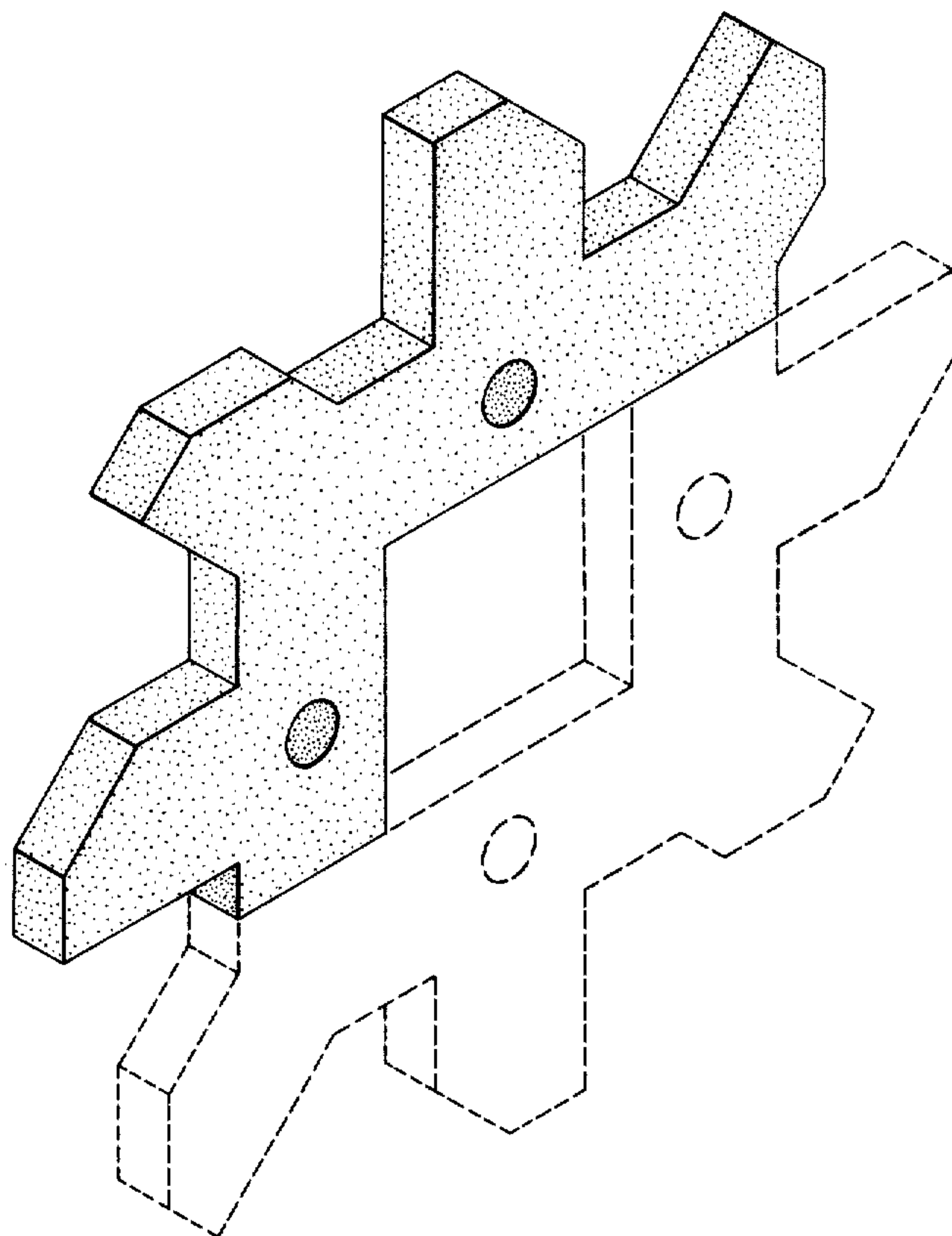

FIG. 2

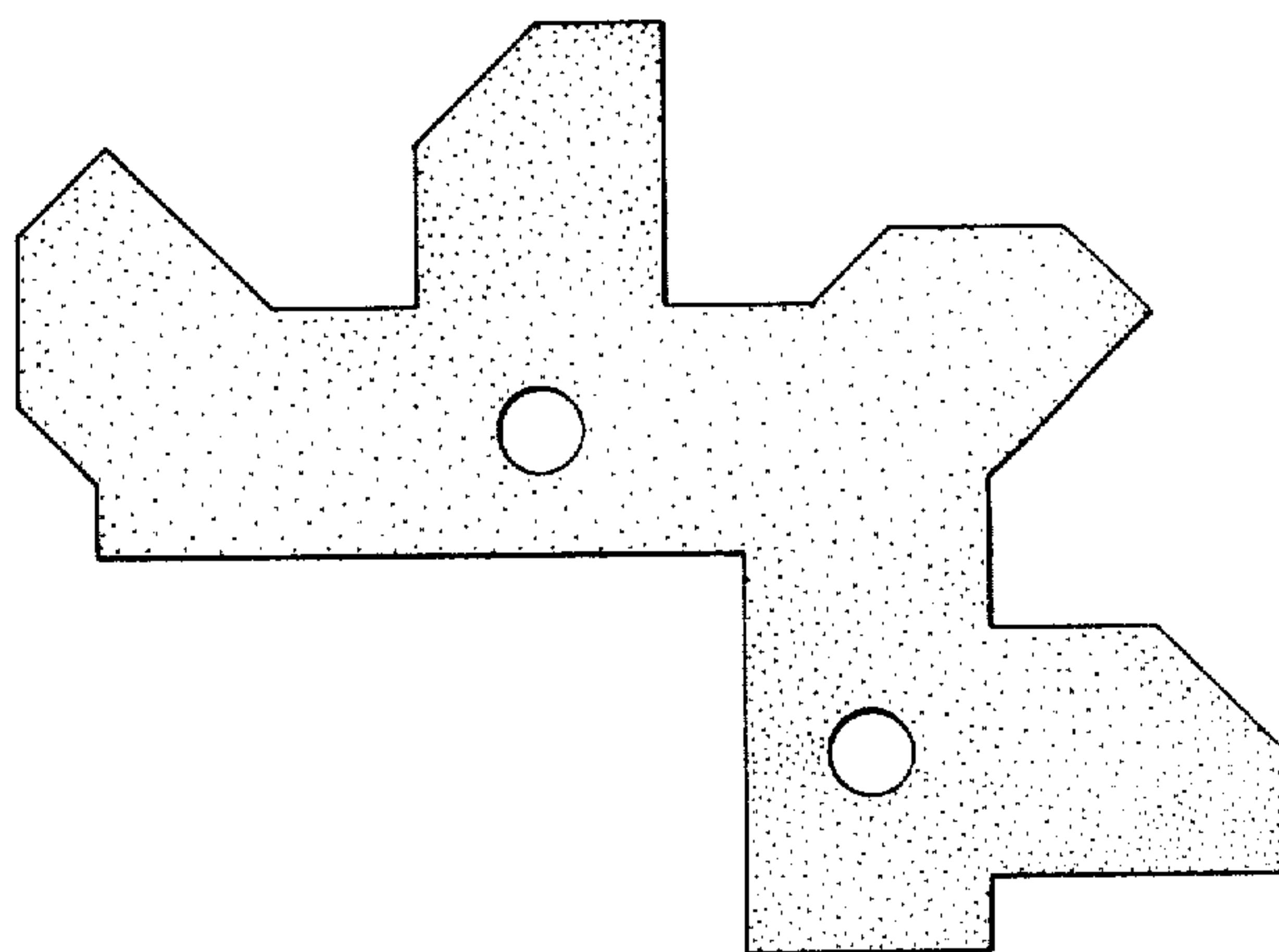

FIG. 3

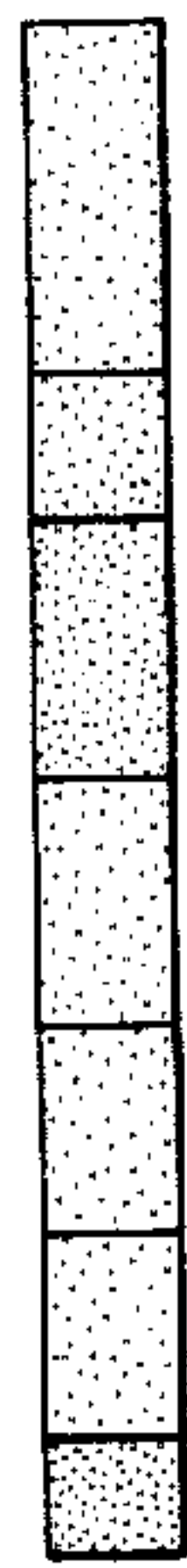

FIG. 4



FIG. 5

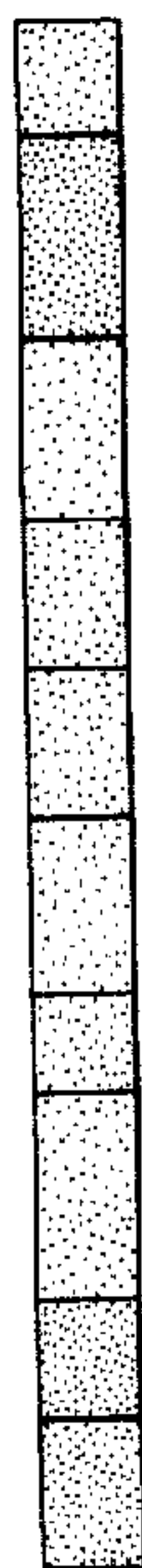

FIG. 6



FIG. 7