

[54] PORTABLE WHEEL CHOCK UNIT

[76] Inventor: Robert A. Moussette, 9C, Chinachem Commercial Centre, 272 Chatham Rd., Kowloon, Hong Kong

[**] Term: 14 Years

[21] Appl. No.: 171,649

[22] Filed: Jul. 23, 1980

[51] Int. Cl. D12-16

[52] U.S. Cl. D12/217

[58] Field of Search D12/217; 188/32

[56] References Cited

U.S. PATENT DOCUMENTS

| | | | |
|-----------|---------|-------------|--------|
| 2,697,494 | 12/1954 | Parks | 188/32 |
| 2,773,564 | 12/1956 | Garard, Sr. | 188/32 |
| 3,317,006 | 5/1967 | Patterson | 188/32 |
| 3,317,007 | 5/1967 | Braun | 188/32 |
| 3,695,394 | 10/1972 | Carpenter | 188/32 |
| 3,811,536 | 5/1974 | Haynes | 188/32 |

Primary Examiner—James M. Gandy
Attorney, Agent, or Firm—Stevens, Davis, Miller & Mosher

[57] CLAIM

The ornamental design for a portable wheel chock unit, substantially as shown and described.

DESCRIPTION

FIG. 1 is a top plan view of a portable wheel chock unit showing my new design;
 FIG. 2 is a bottom plan view thereof;
 FIG. 3 is a left side elevational view thereof;
 FIG. 4 is a right side elevational view thereof;
 FIG. 5 is a front elevational view thereof;
 FIG. 6 is a rear elevational view thereof;
 FIG. 7 is a bottom front perspective view thereof with the smaller chock partially slidably inserted into the hollow of the larger chock for transportation and storage;
 FIG. 8 is a top left side perspective view thereof with the chocks spaced closer together; and
 FIG. 9 is a top, front, right side perspective view of a portable wheel chock unit showing a second embodiment of my new design, the sole difference resides in the triangular cross sectional shape thereof it being understood that the smaller chock is in its stored condition within the hollow of the larger chock shown.

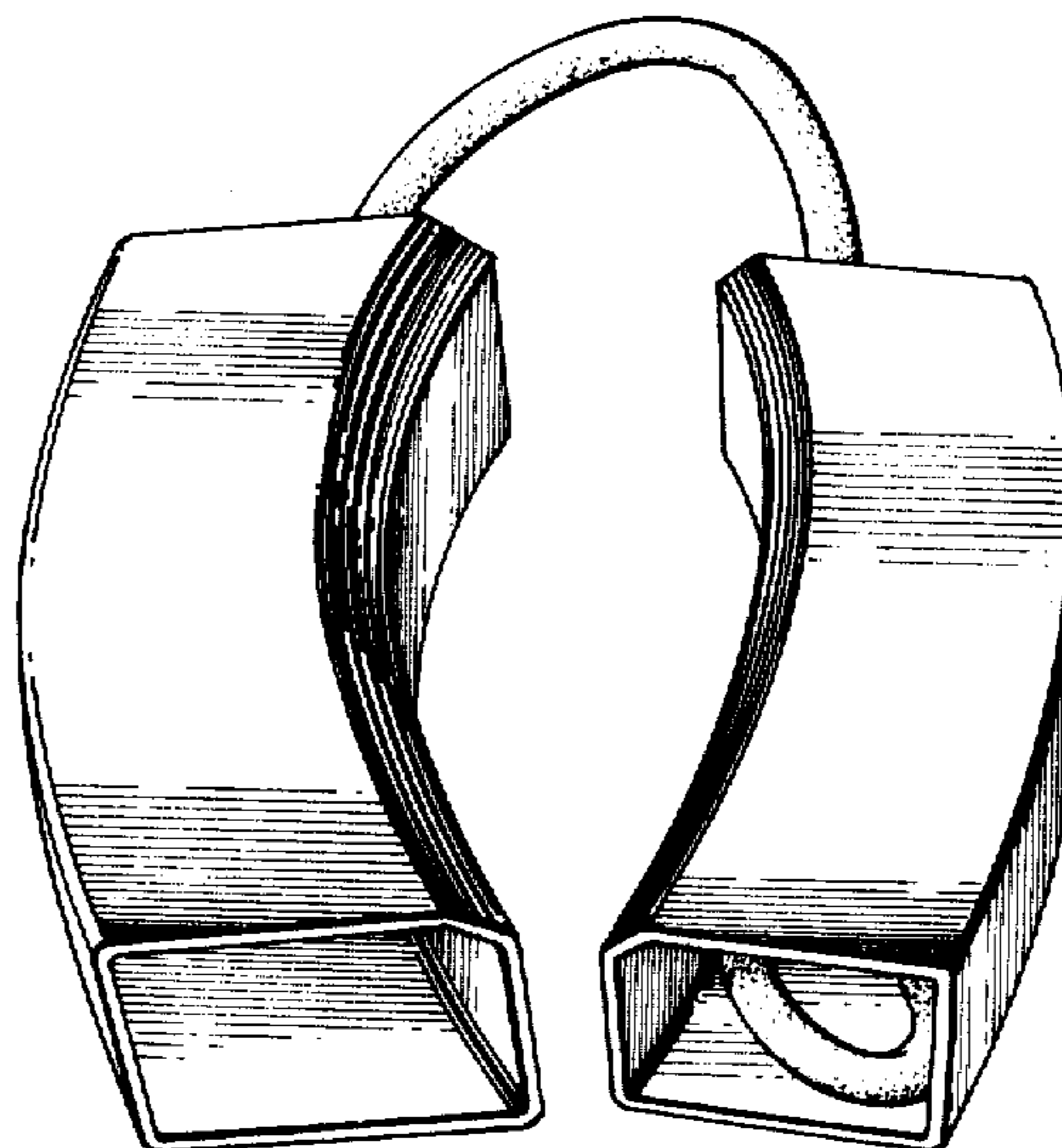
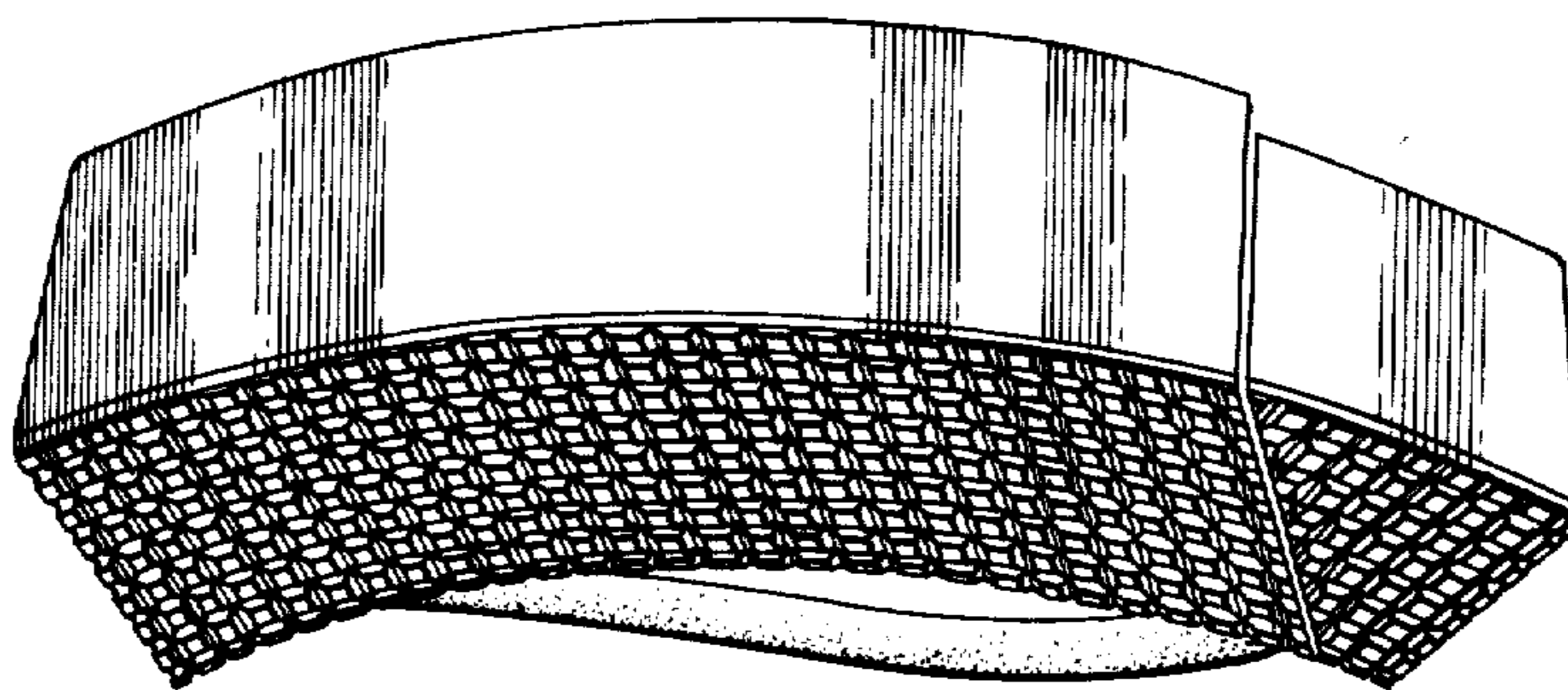

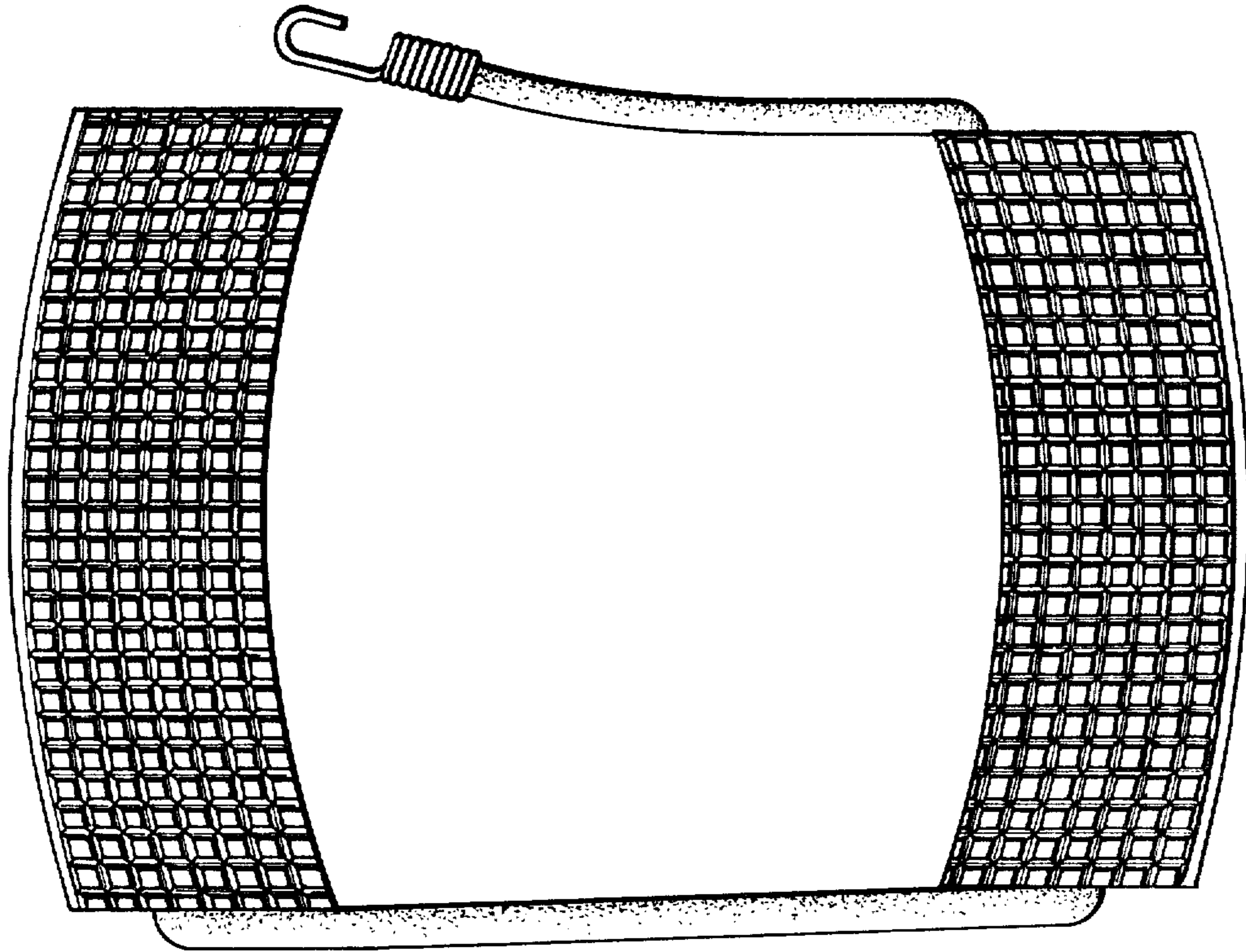

FIG. 2

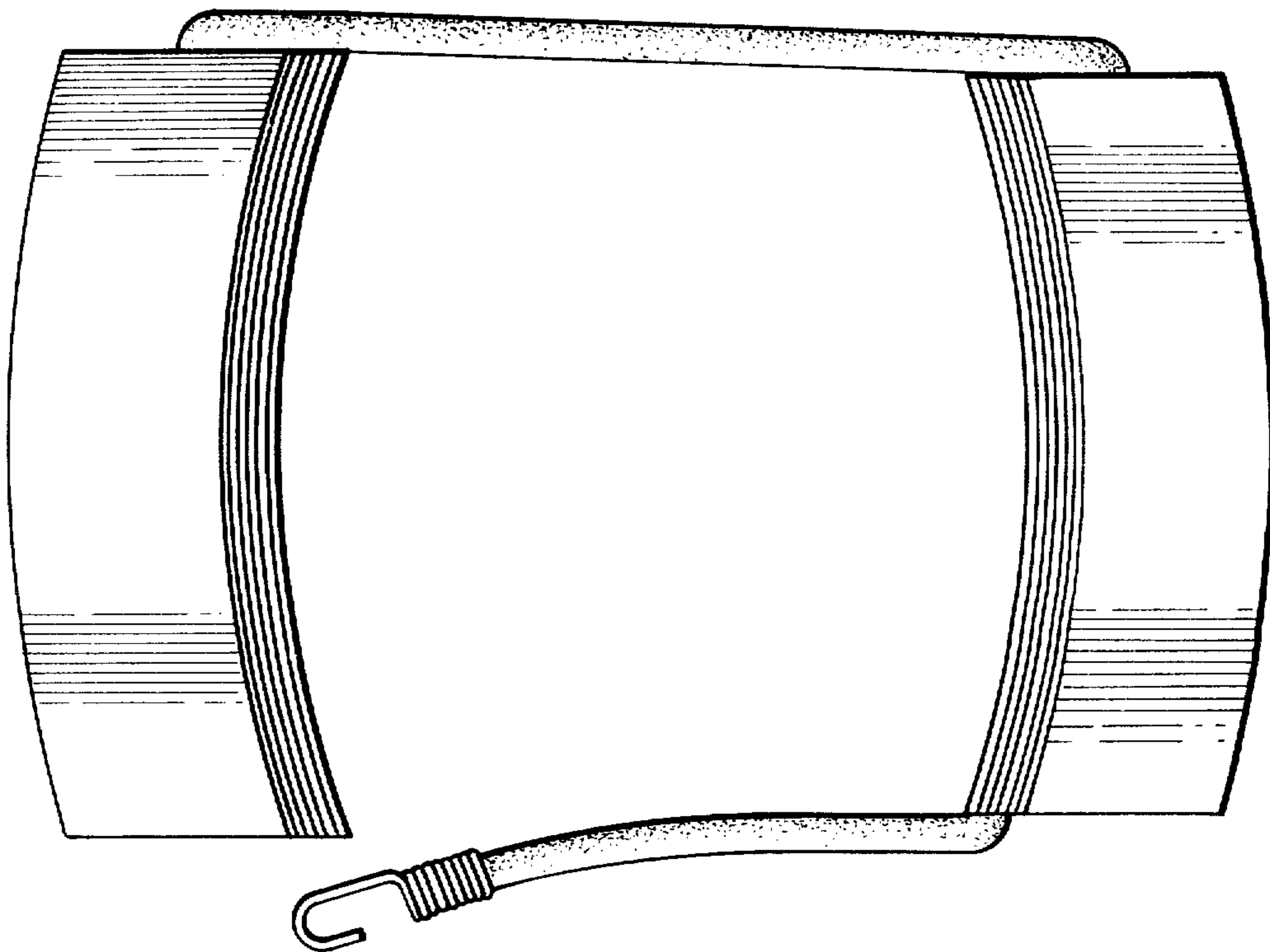

FIG. 1

FIG. 3

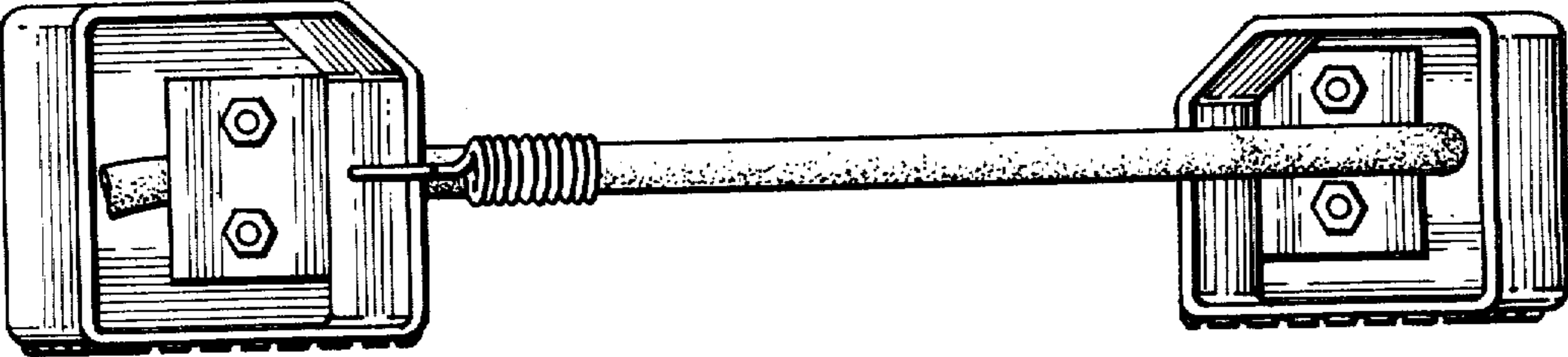

FIG. 4



FIG. 5

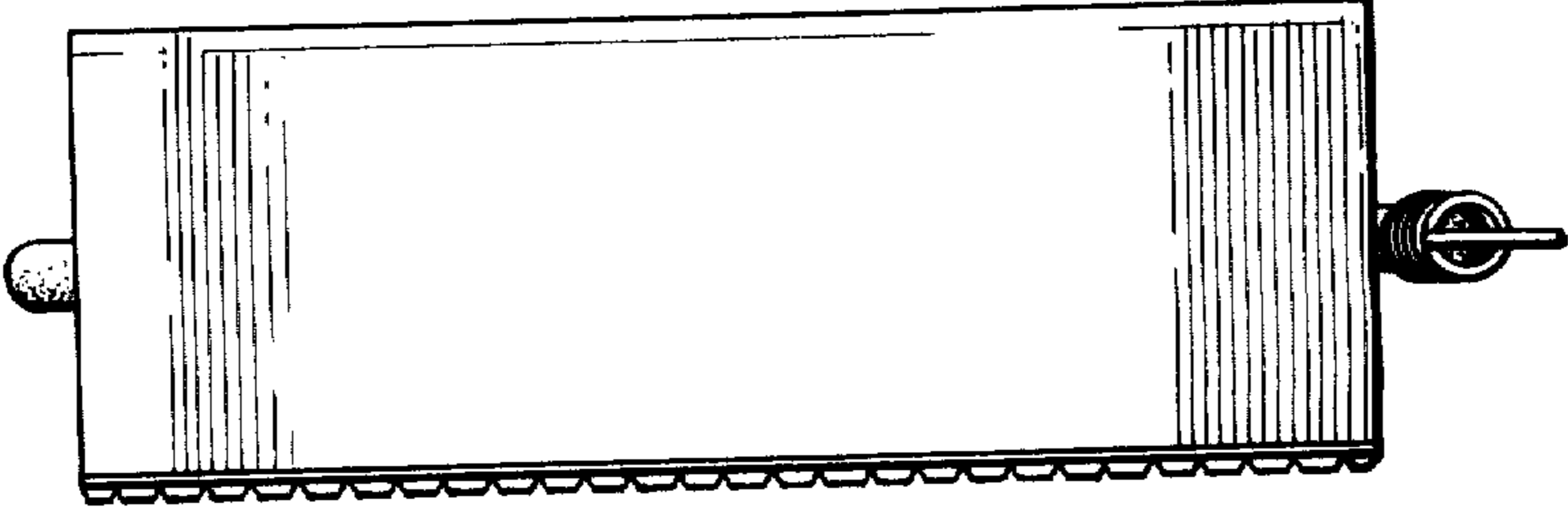
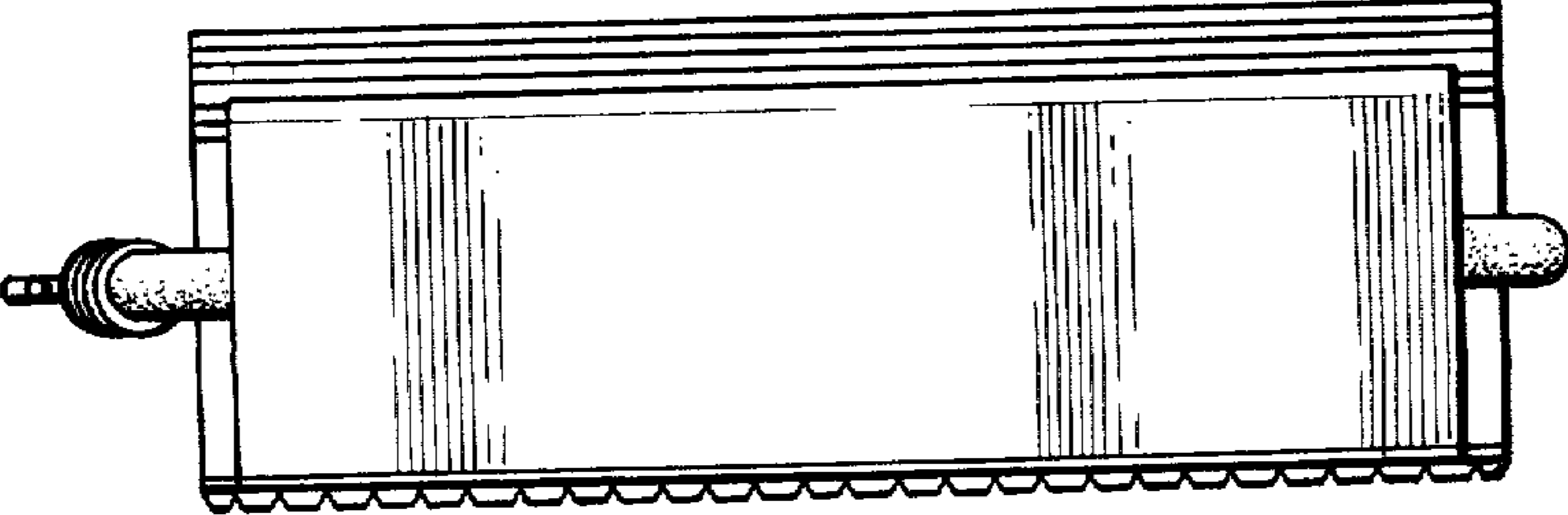

FIG. 6



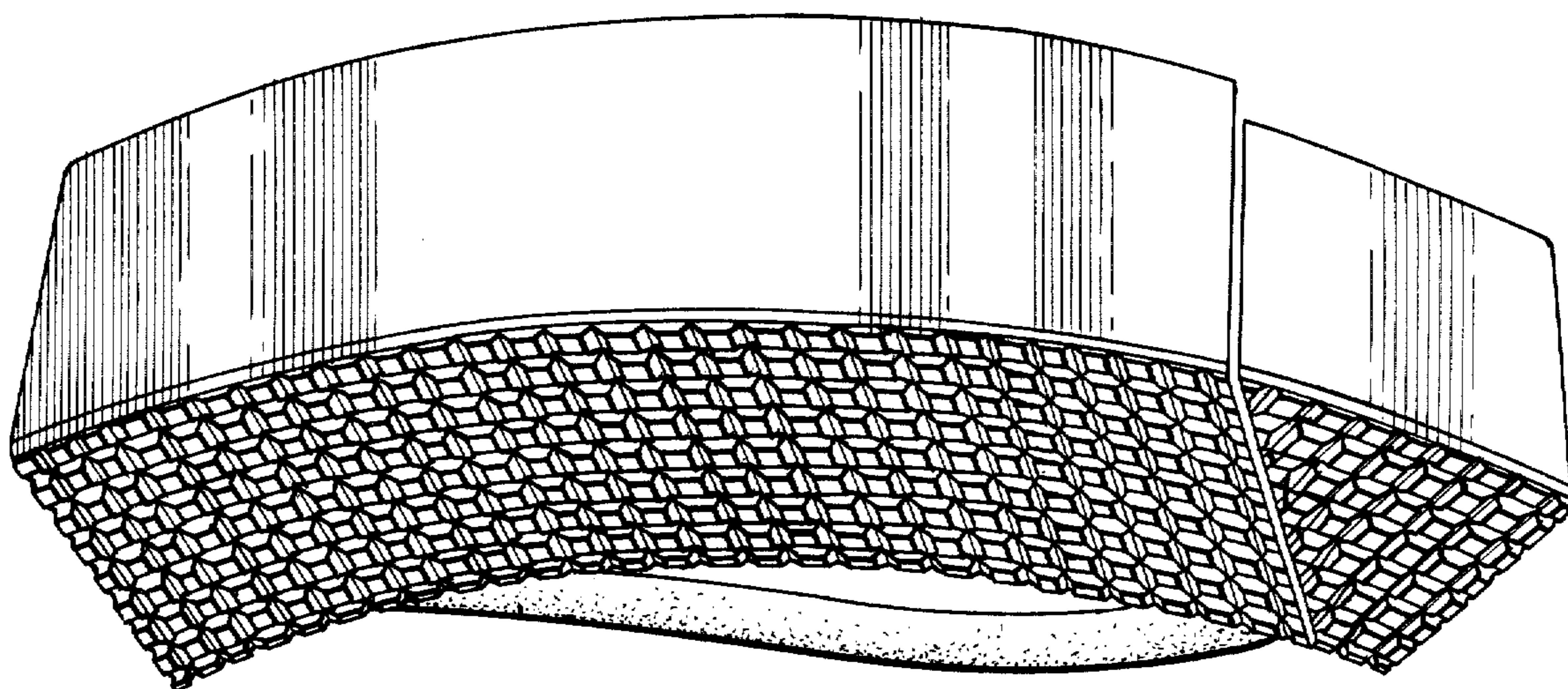

FIG. 7

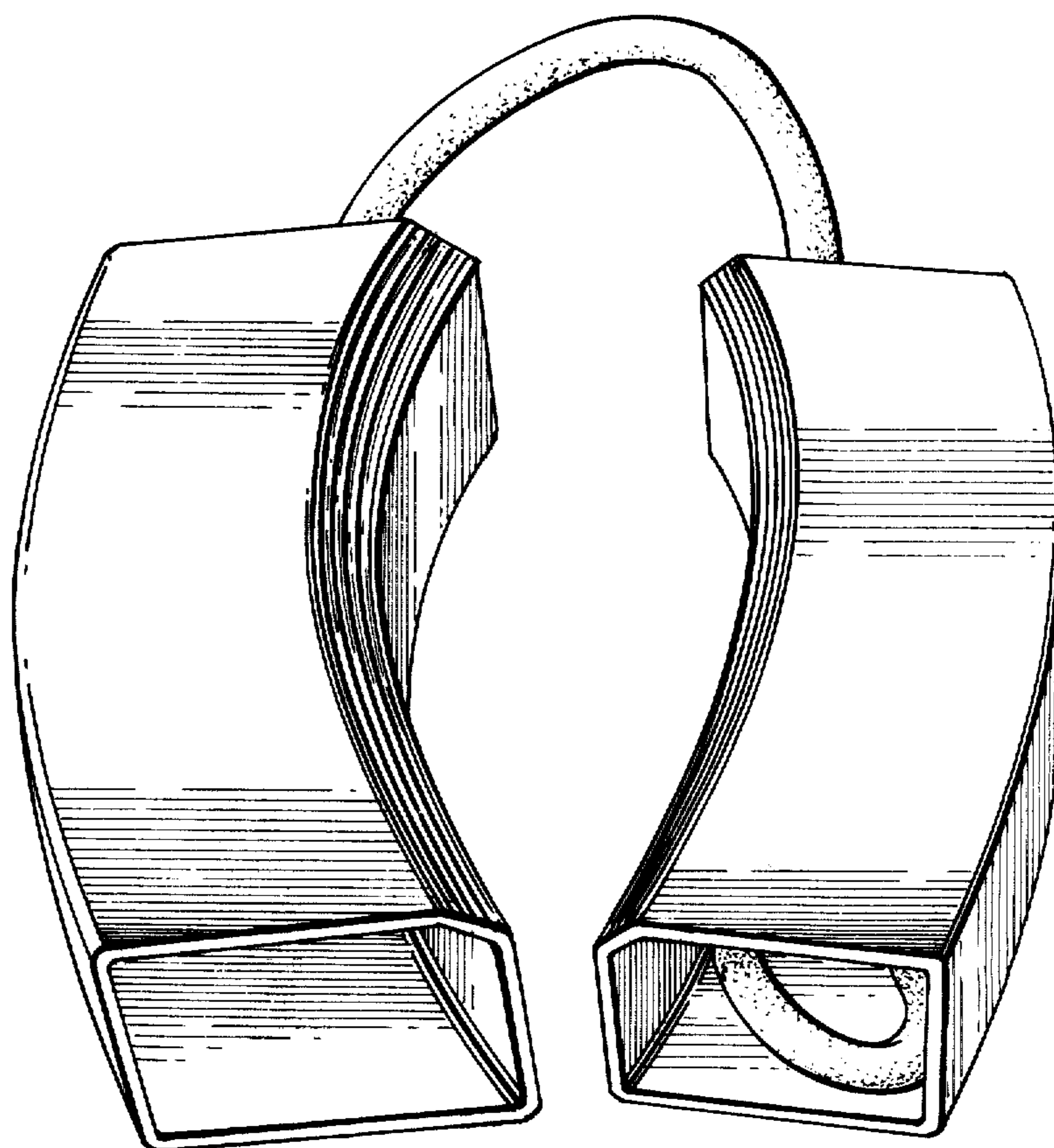

FIG. 8

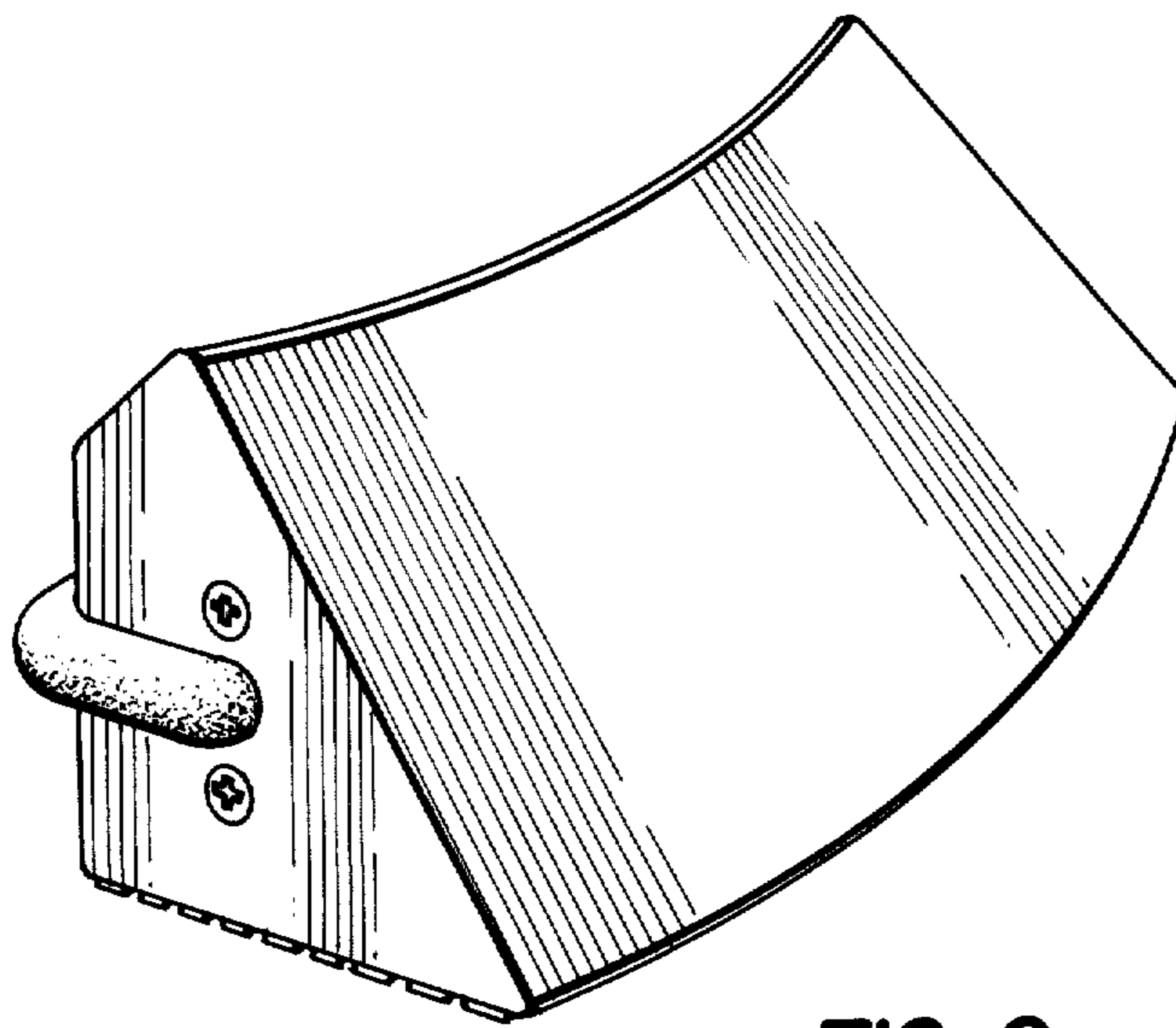

FIG. 9