

[54] **CANAPE MAKER OR THE LIKE**

[76] Inventor: **Robert S. Lutzker**, 21 Lee Ave., East Williston, N.Y. 11596

[\*\*] Term: **14 Years**

[21] Appl. No.: **209,468**

[22] Filed: **Nov. 24, 1980**

[51] Int. Cl. .... **D07-04**

[52] U.S. Cl. .... **D7/43; D7/99**

[58] Field of Search ..... **D7/43, 99; 425/191; 249/117**

[56] **References Cited**

**U.S. PATENT DOCUMENTS**

D. 104,773	6/1937	Ganary .....	D7/99
D. 245,140	7/1977	Benson .....	D7/99
563,652	7/1896	Bulette .....	D7/43 X
1,686,280	10/1928	Keller .....	D7/157 X
2,980,247	4/1961	Di Giantomasso .....	D7/99 X
3,759,478	9/1973	Schmitt et al. ....	249/117 X
3,943,602	3/1976	Siclari .....	D7/43 X

*Primary Examiner*—Winifred E. Herrmann  
*Attorney, Agent, or Firm*—Kane, Dalsimer, Kane, Sullivan and Kurucz

[57] **CLAIM**

The ornamental design for a canape maker or the like, as shown and described.

**DESCRIPTION**

FIG. 1 is a perspective view of a canape maker or the like having a circular cross-section with the piston fully inserted showing my design; FIG. 2 is a similar view with the piston fully retracted; FIG. 3 is a bottom plan view thereof; FIG. 4 is a perspective view of an alternate embodiment of a canape maker or the like having a square cross-section with the piston fully inserted showing my design; FIG. 5 is a similar view with the piston fully retracted; FIG. 6 is a bottom plan view thereof; FIG. 7 is a perspective view of an alternate embodiment of a canape maker or the like having a hexagonal cross-section with the piston fully inserted showing my design; FIG. 8 is a similar view with the piston fully retracted; FIG. 9 is a bottom plan view thereof; FIG. 10 is a perspective view of an alternate embodiment or the like having an elliptical cross-section with the piston fully inserted showing my design; FIG. 11 is a similar view with the piston fully retracted; and FIG. 12 is a bottom plan view thereof.

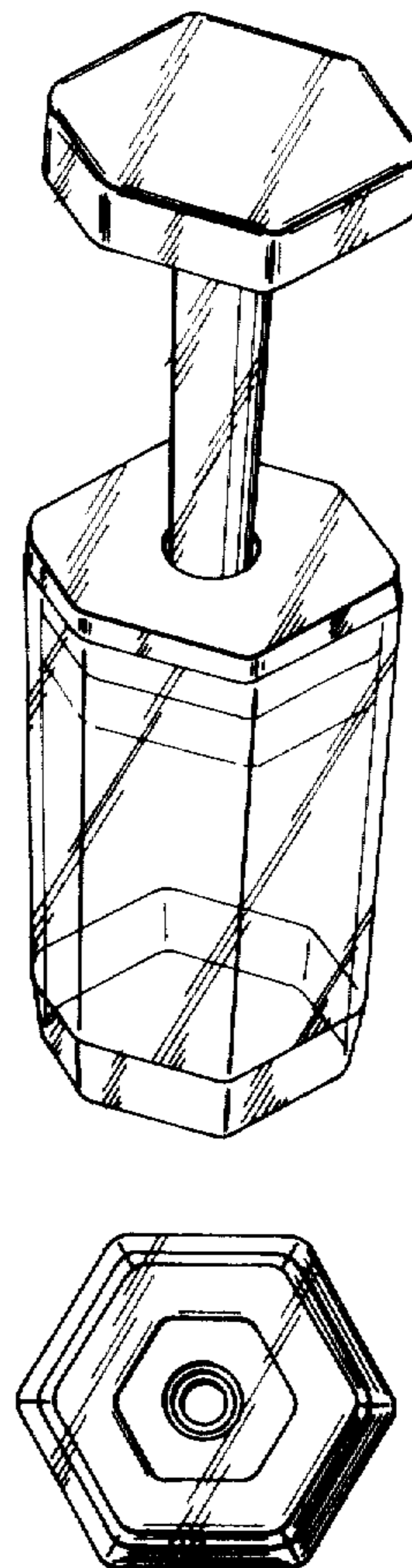
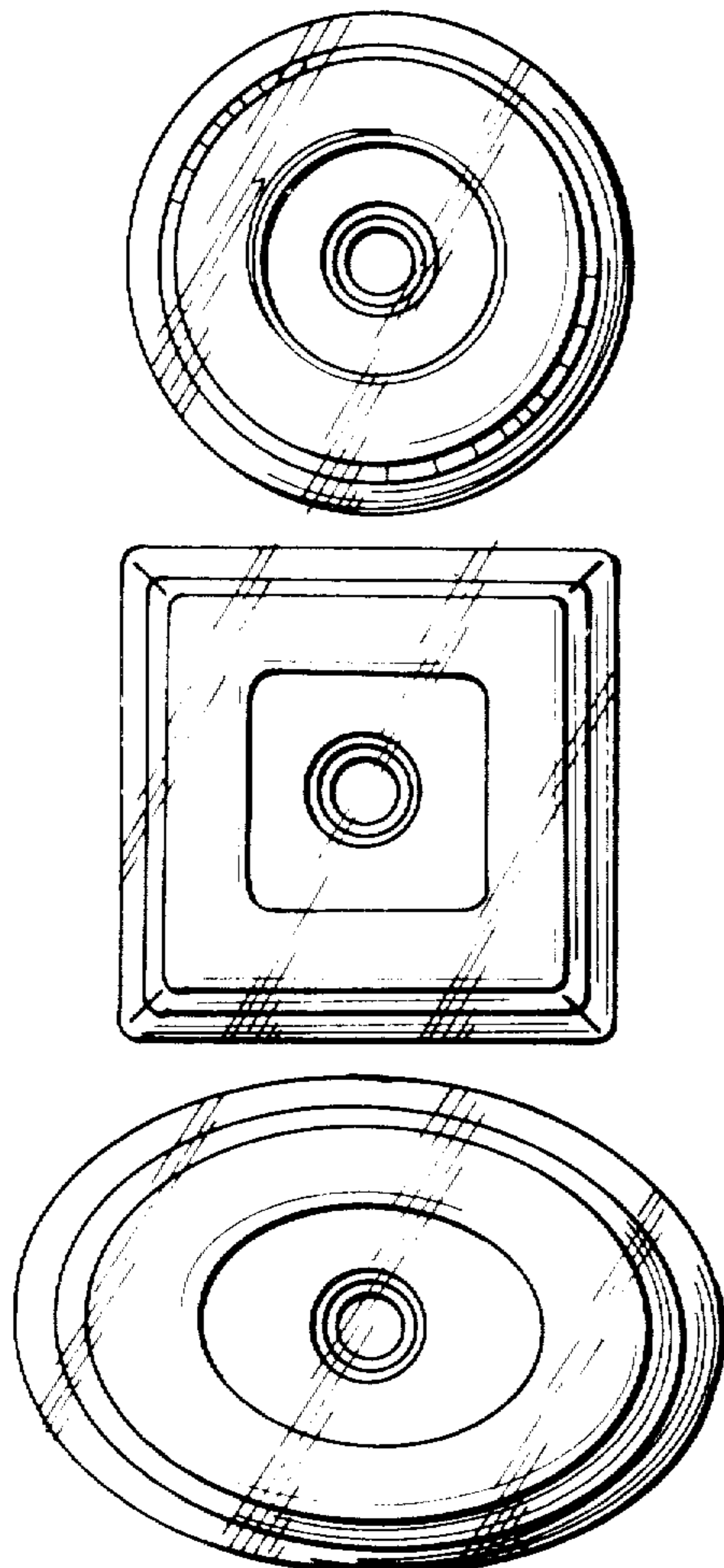

FIG. 1

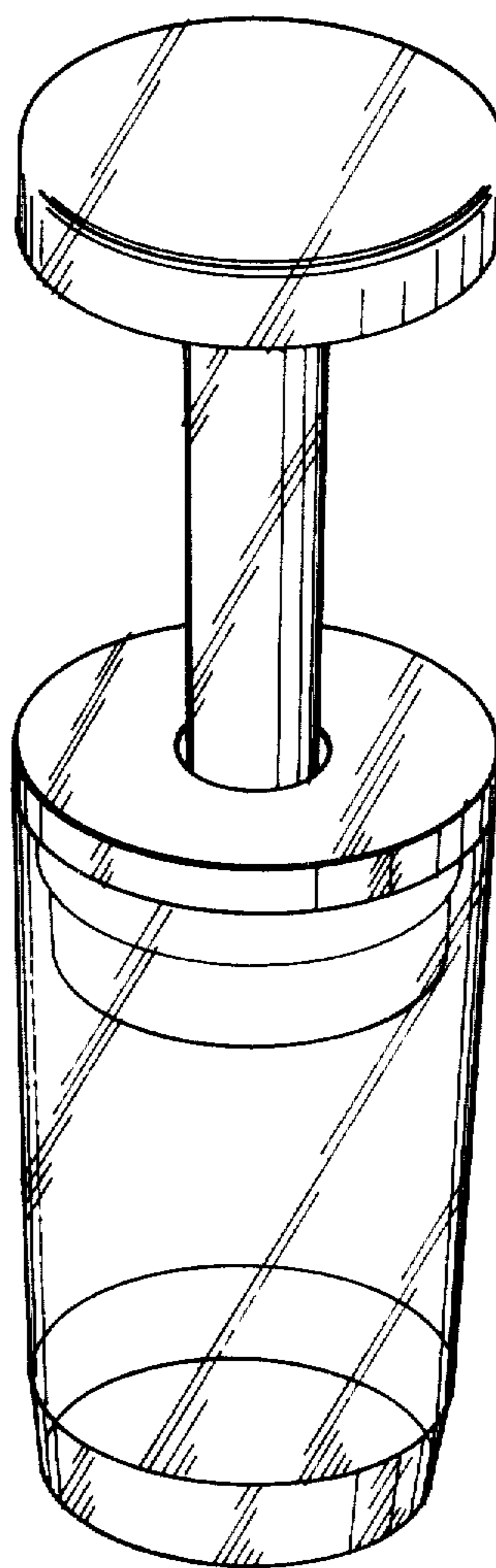
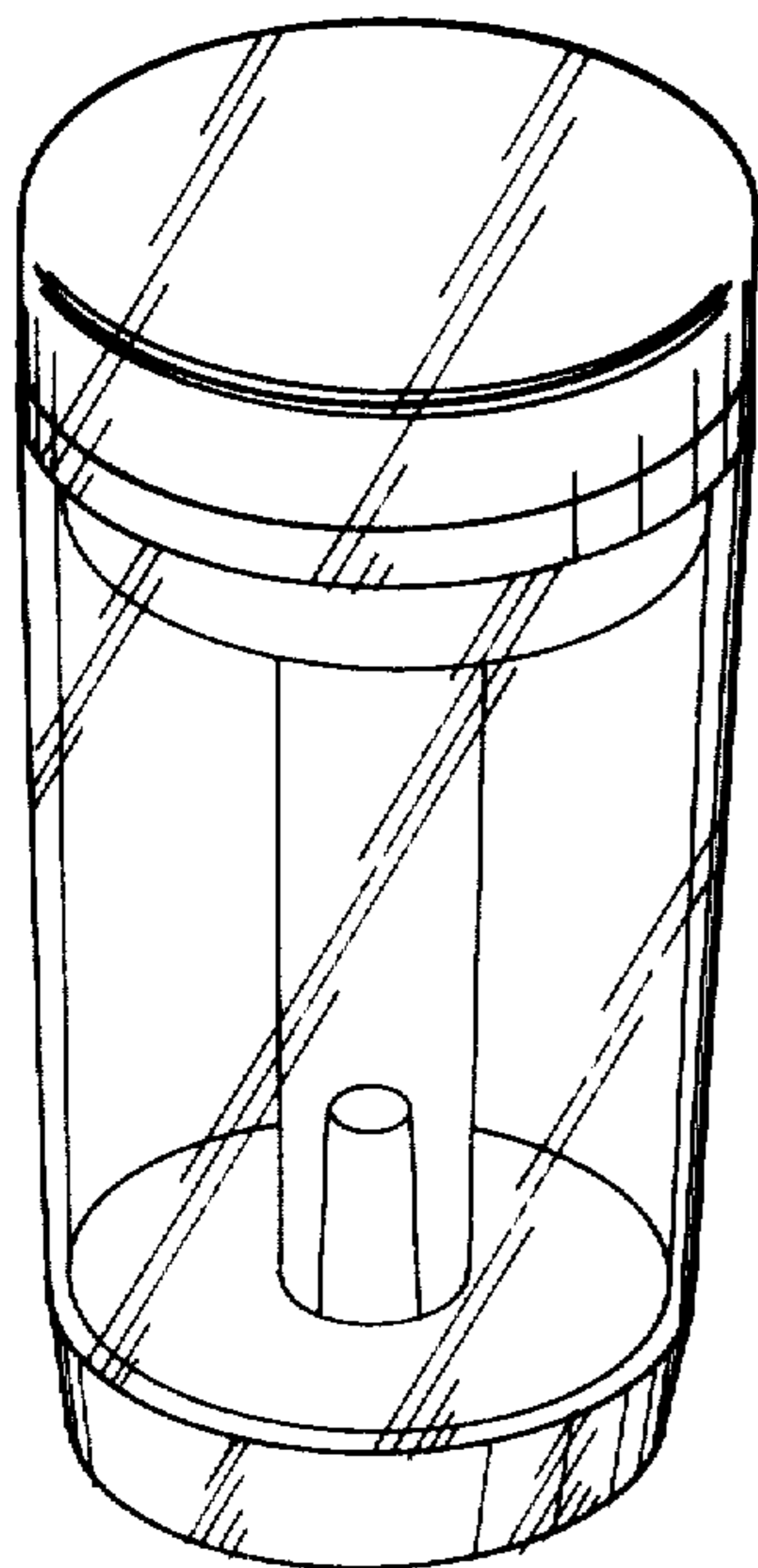

FIG. 3

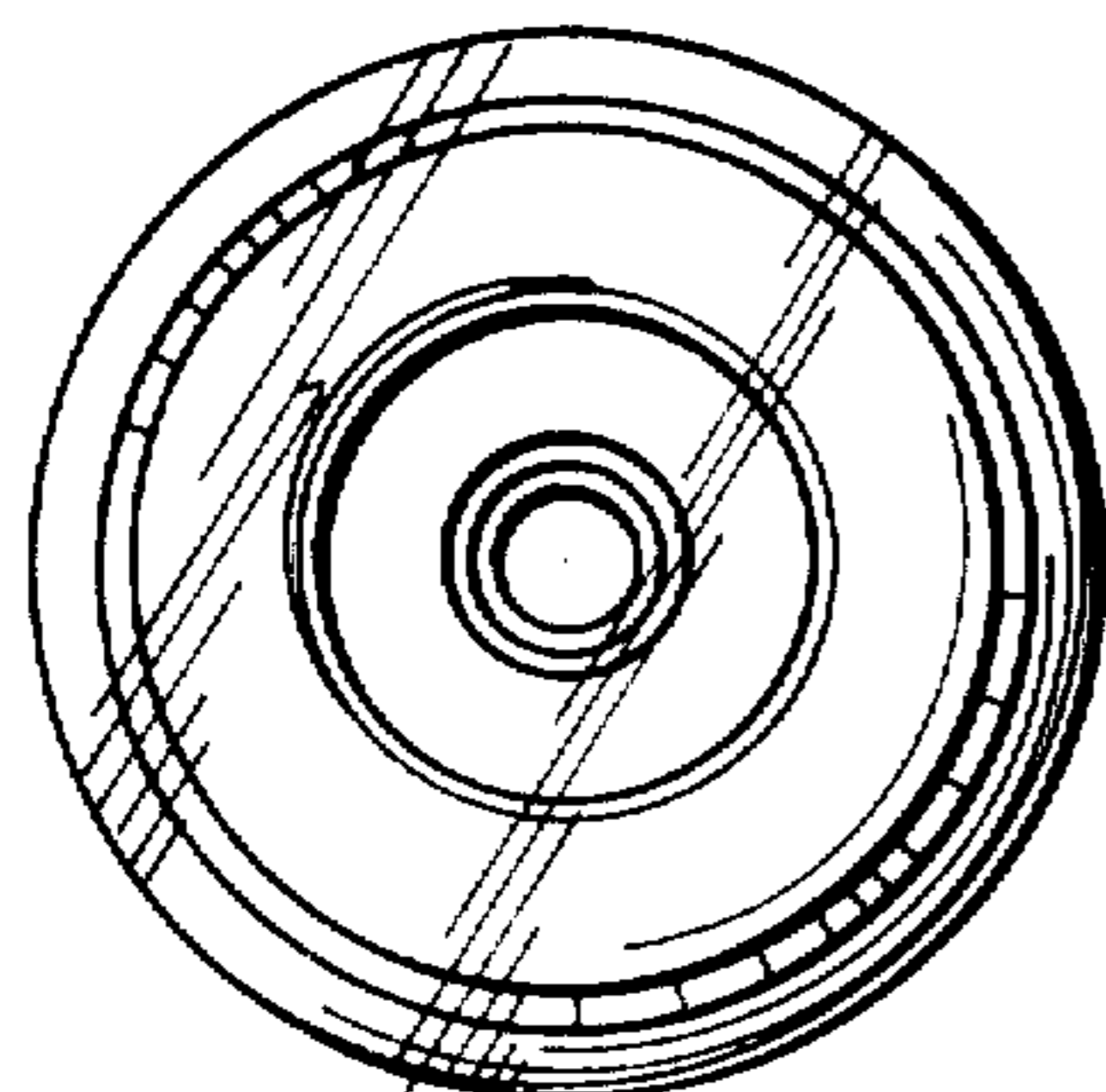

FIG. 2

FIG. 4

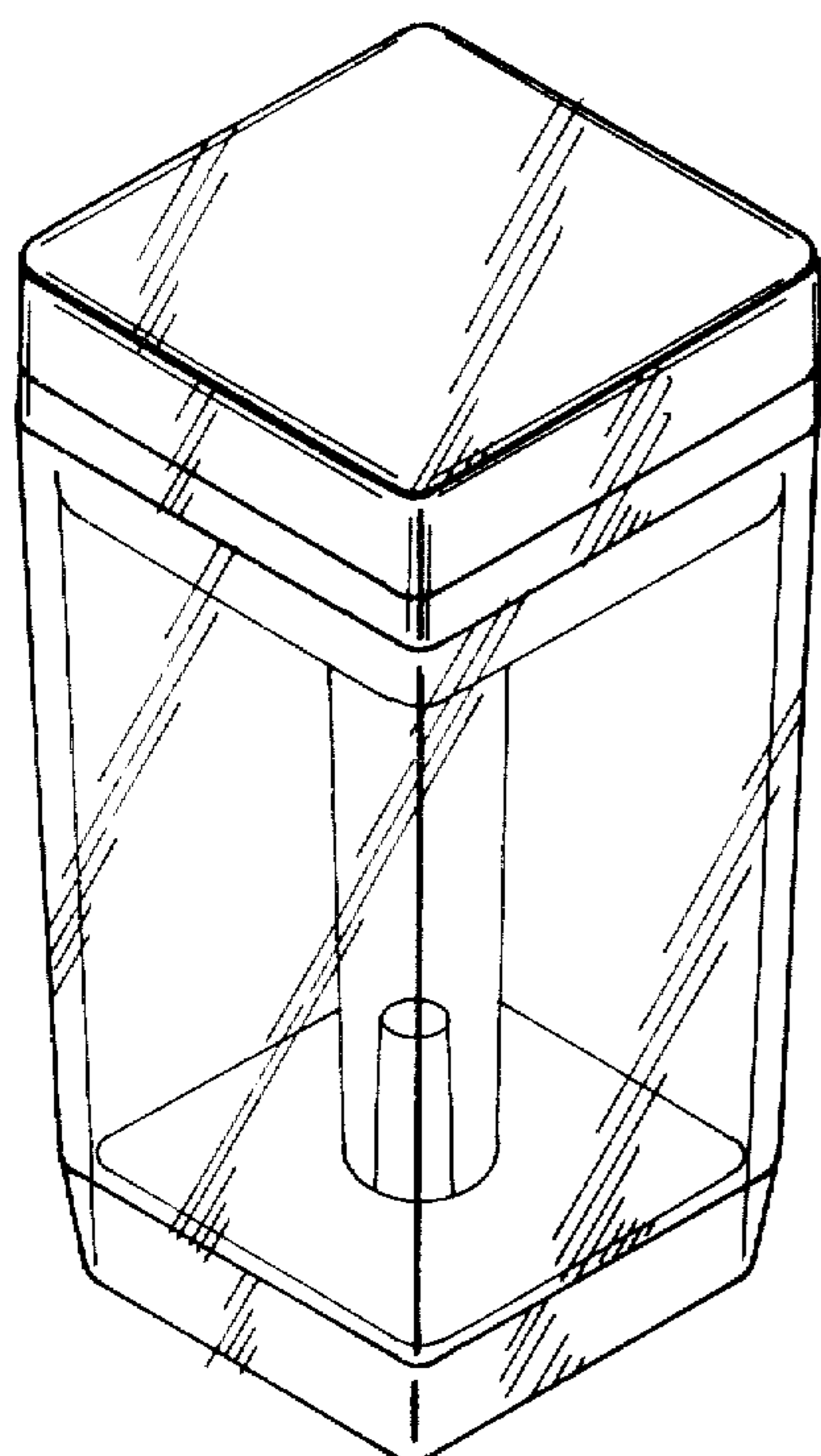

FIG. 6

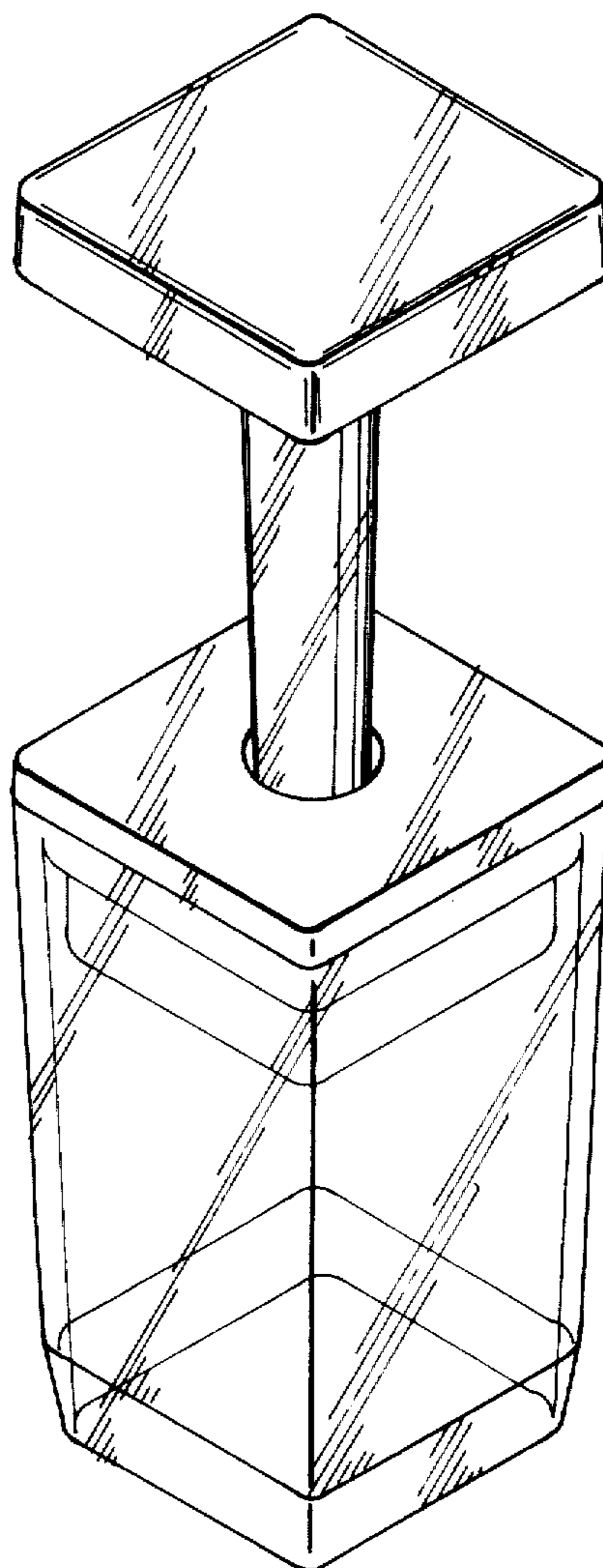
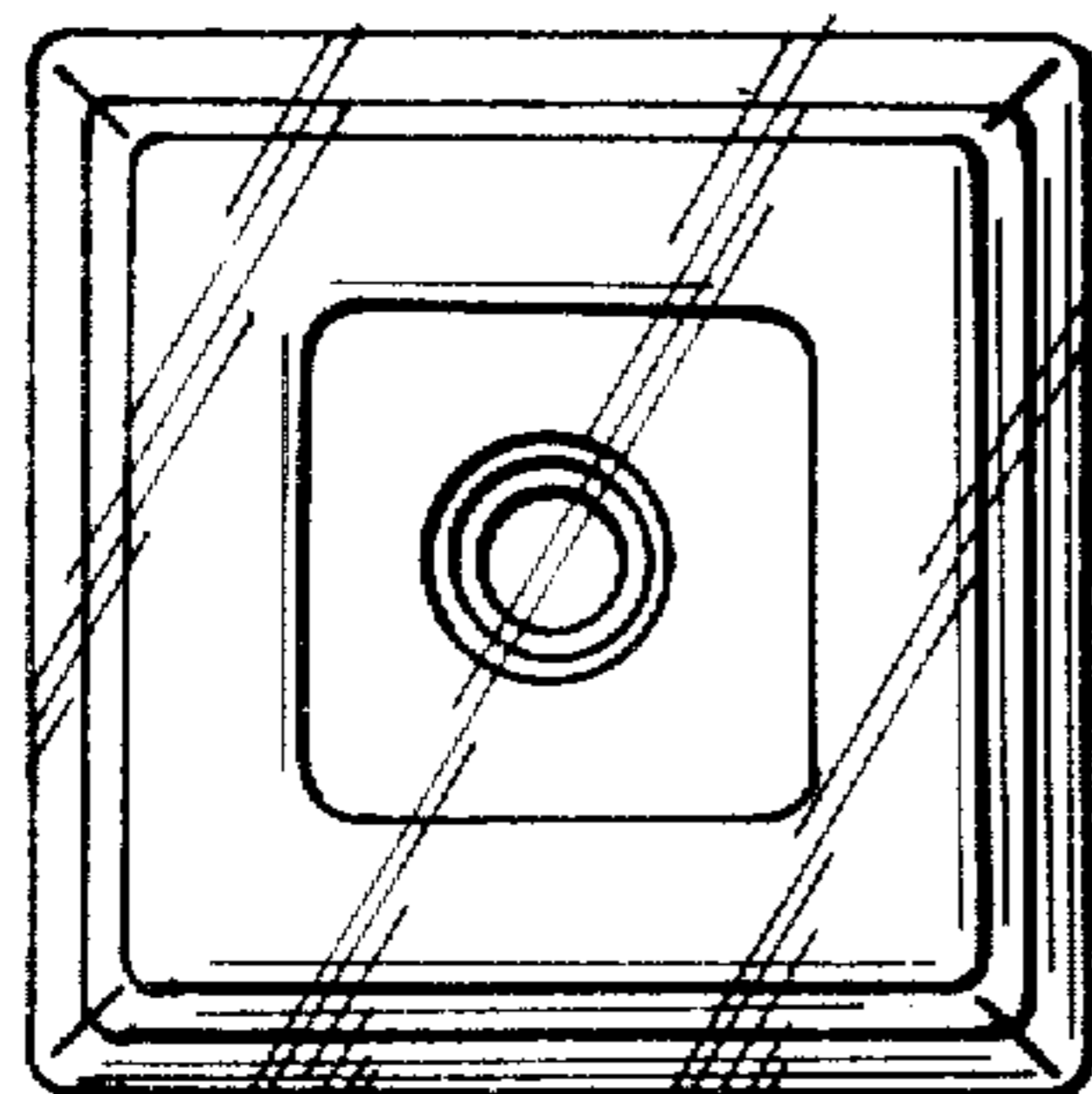

FIG. 5

FIG. 7

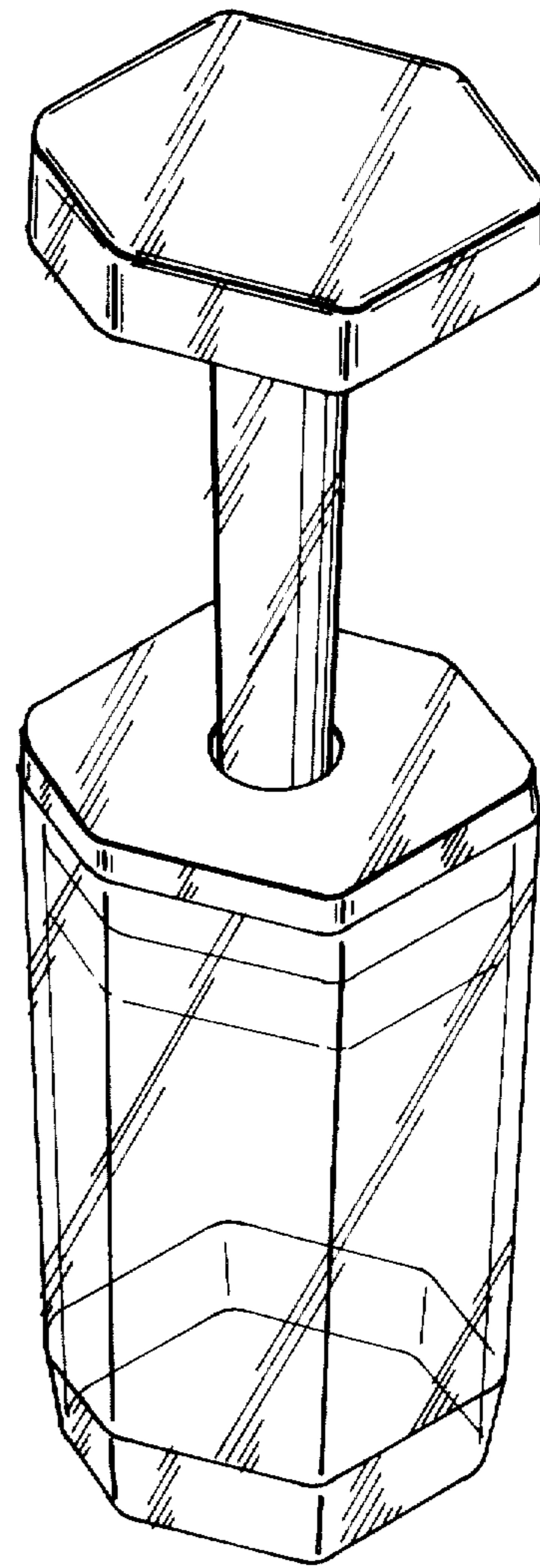
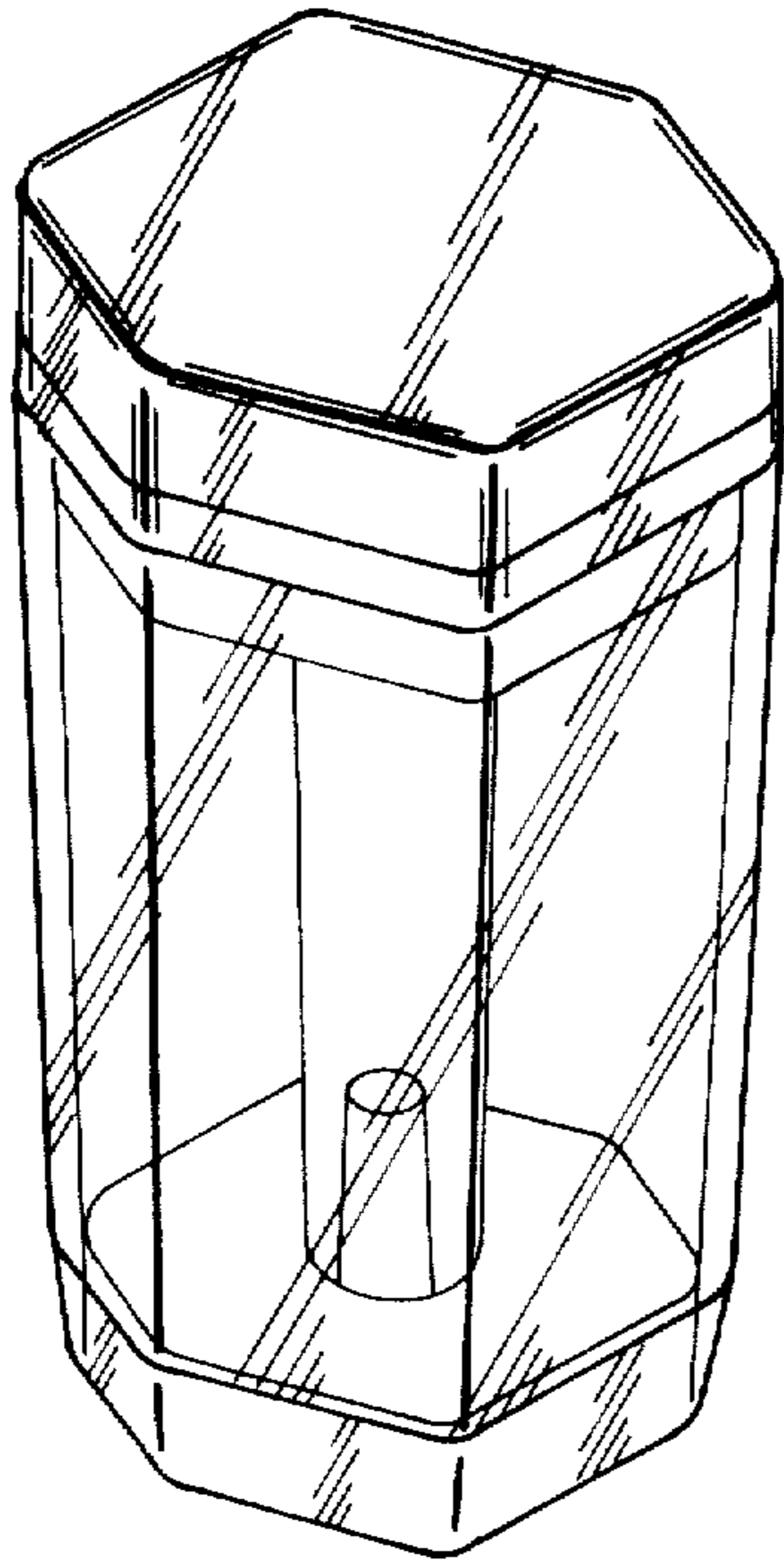

FIG. 9

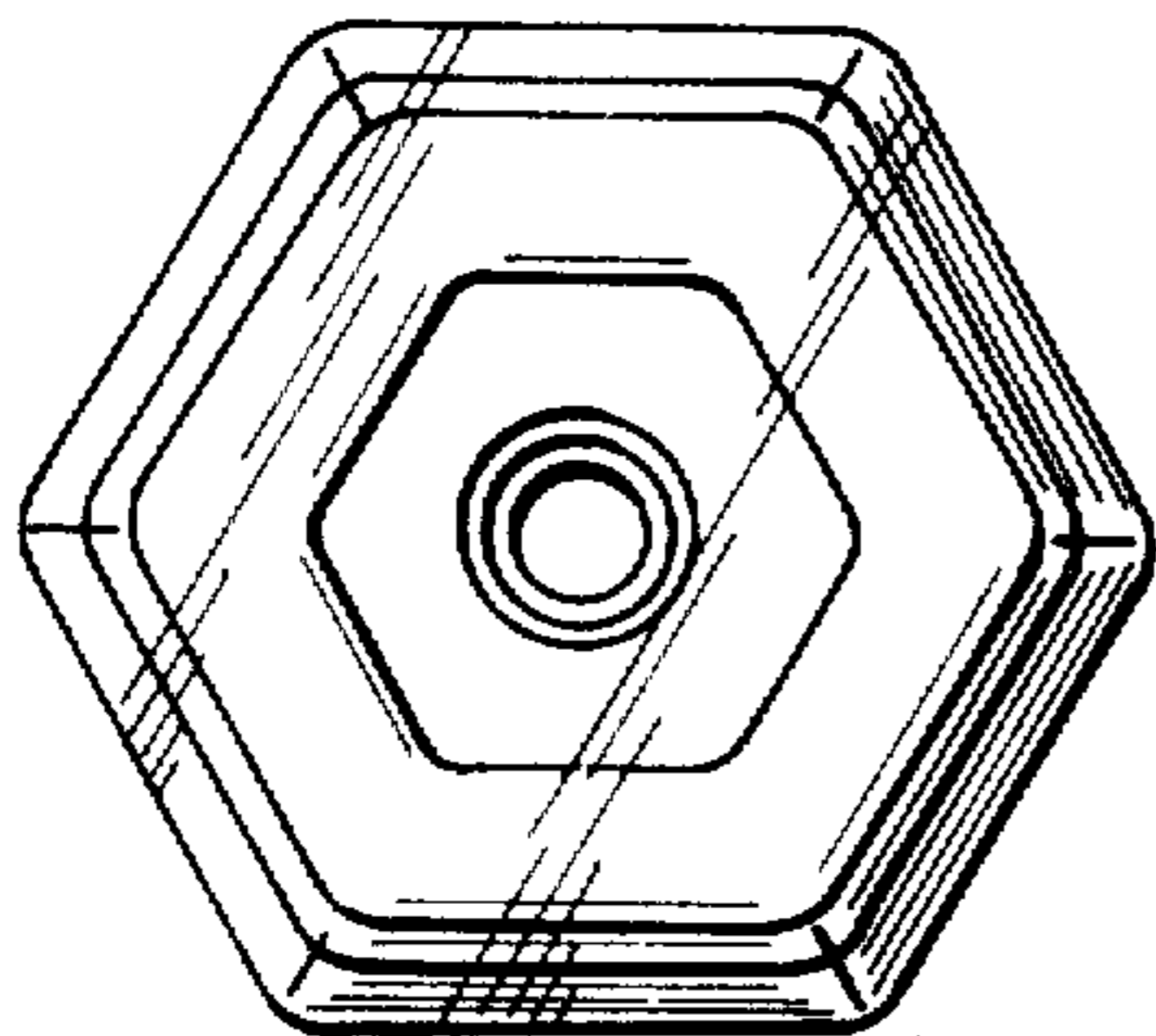

FIG. 8

FIG. 10

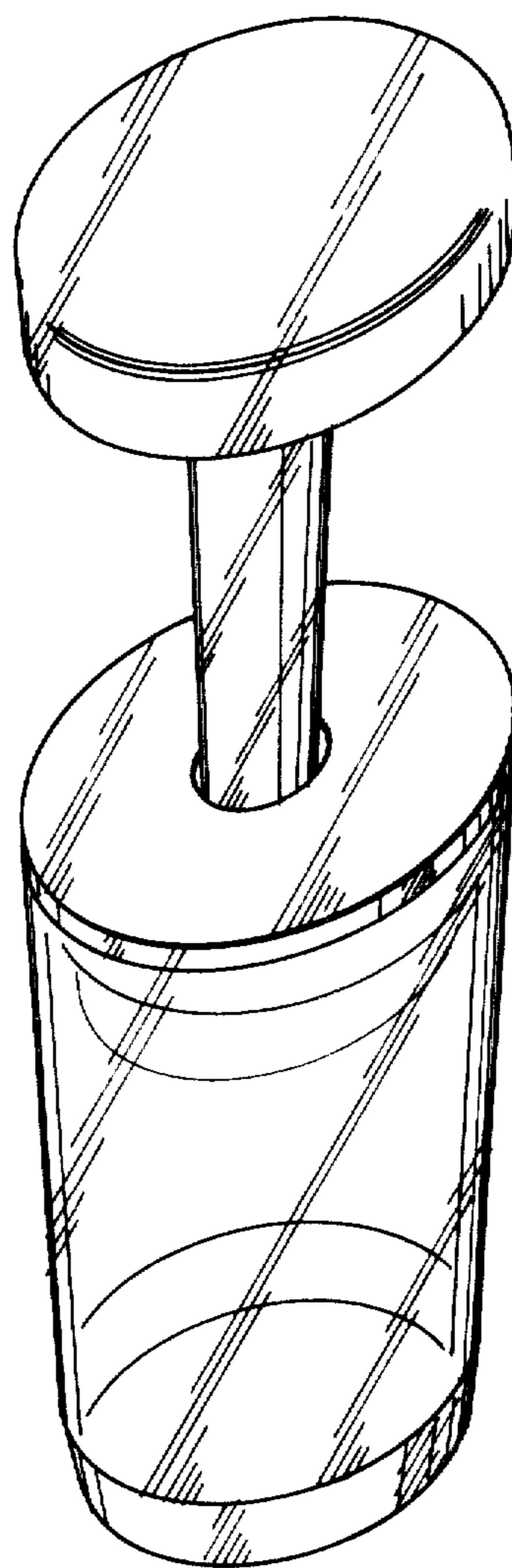
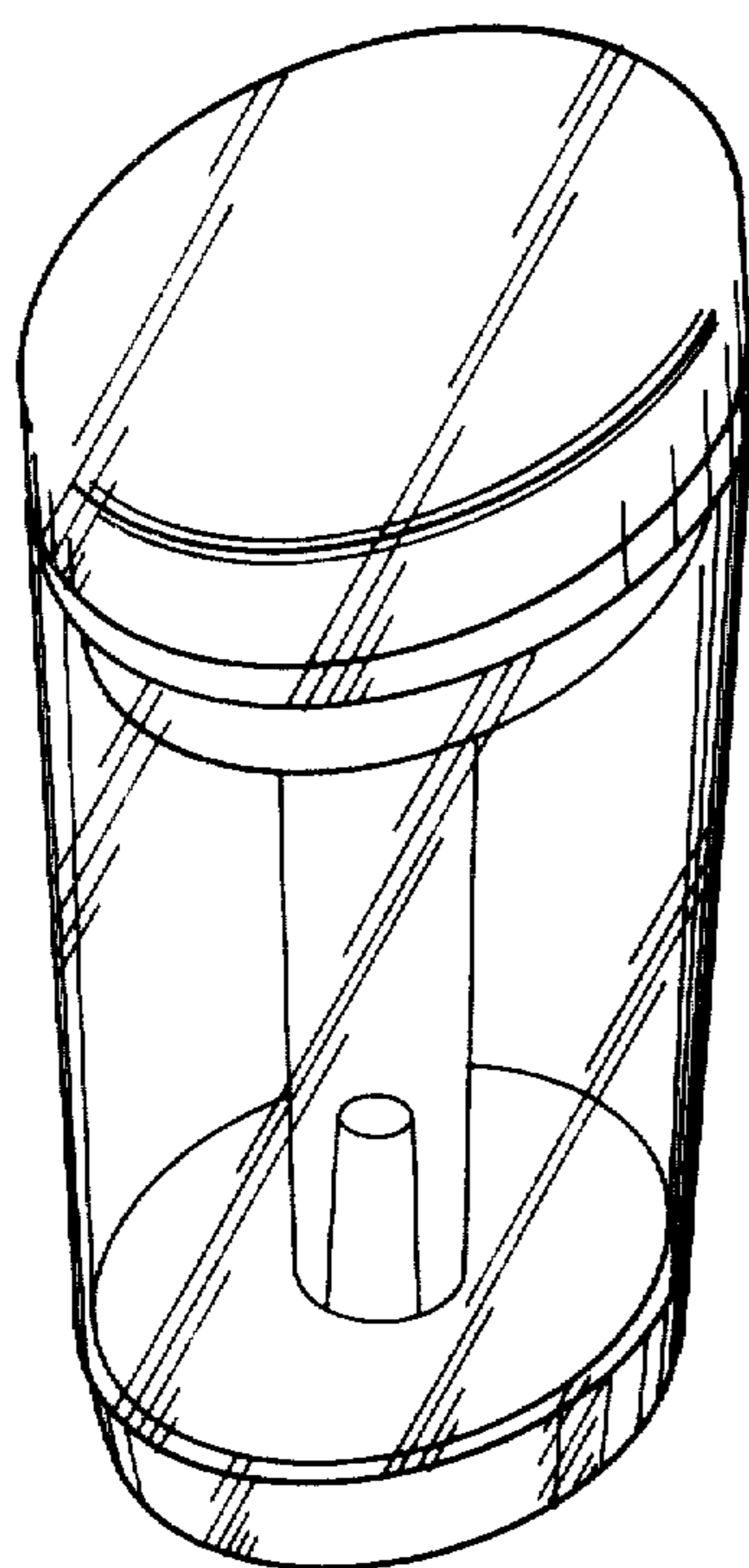

FIG. 12

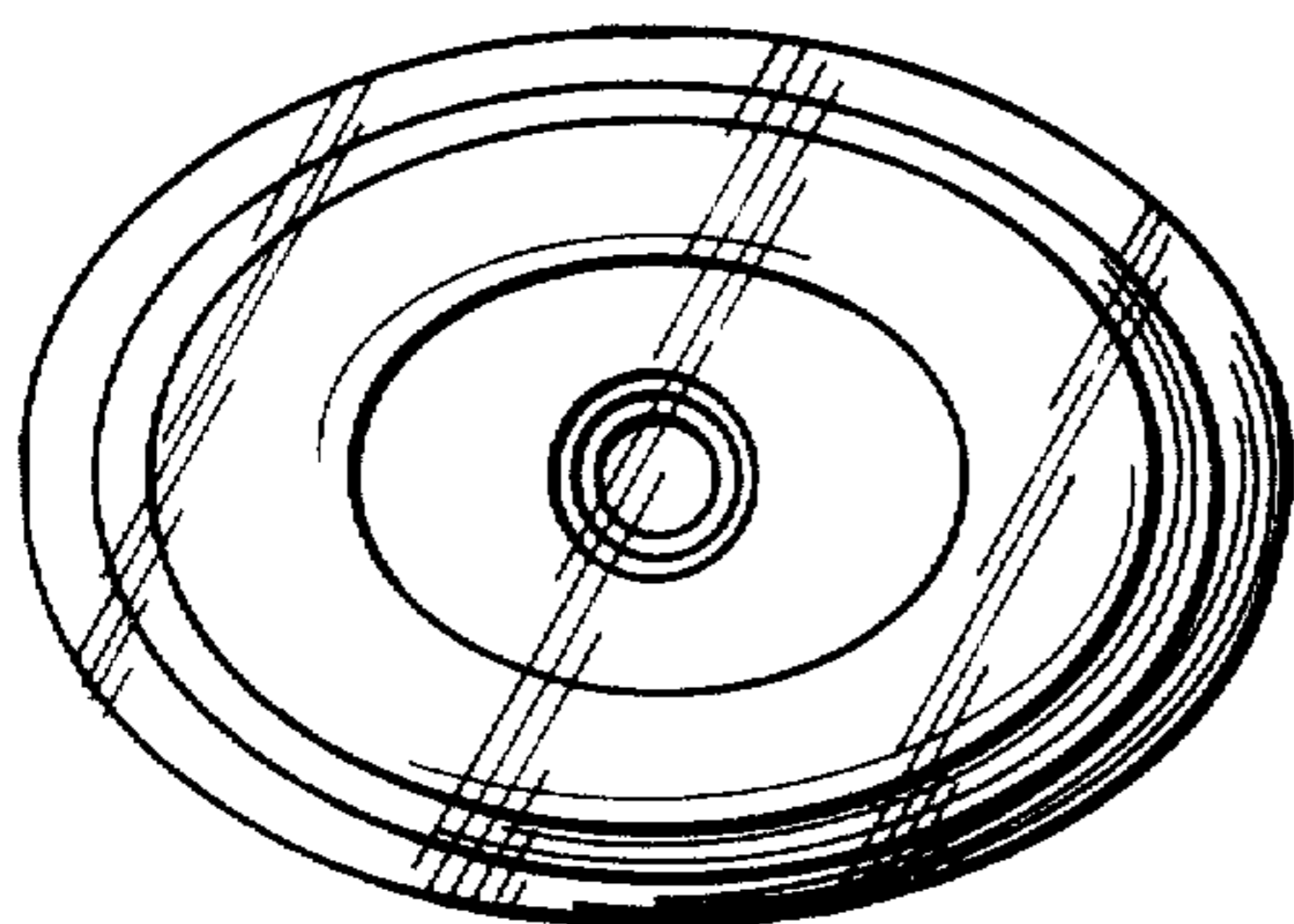

FIG. 11