

[54] BOTTLE LAMP

[76] Inventor: Harlan S. Leeds, 3667 Northhaven, Dallas, Tex. 75221

[**] Term: 14 Years

[21] Appl. No.: 125,553

[22] Filed: Feb. 28, 1980

[51] Int. Cl. D26-05

[52] U.S. Cl. D26/94

[58] Field of Search D26/24, 93, 94, 101, D26/102, 103, 104, 105, 106, 107, 109, 111, 110; 362/806, 410, 411, 412, 414, 395, 418

[56] References Cited

U.S. PATENT DOCUMENTS

- D. 169,020 3/1953 Wentzell D26/94
- 1,484,648 2/1924 Jenkins 362/418 X
- 1,952,276 3/1934 Monk 362/414

FOREIGN PATENT DOCUMENTS

831057 7/1949 Fed. Rep. of Germany 362/412

OTHER PUBLICATIONS

Lamp Journal, 9-1969, p. 36, Novelty Bar Lamp #426.
House Beautiful, 9-1973, p. 26, Lucite Lamp.
Liquor Store Magazine, 4-1975, p. 13, Bottle #J 2775LS; p. 165, Bottle #Z 1675LS.

Primary Examiner—Susan J. Lucas
Attorney, Agent, or Firm—Howard R. Greenberg

[57] CLAIM

The ornamental design for a bottle lamp, as shown and described.

DESCRIPTION

FIG. 1 is a perspective view of a first embodiment of the design for bottle lamp.
FIG. 2 is a perspective view of a second embodiment of the design.
FIG. 3 is a perspective view of a third embodiment of the design.
FIGS. 4, 5 and 6 are respectively side elevational views of the first, second and third embodiments of my design.

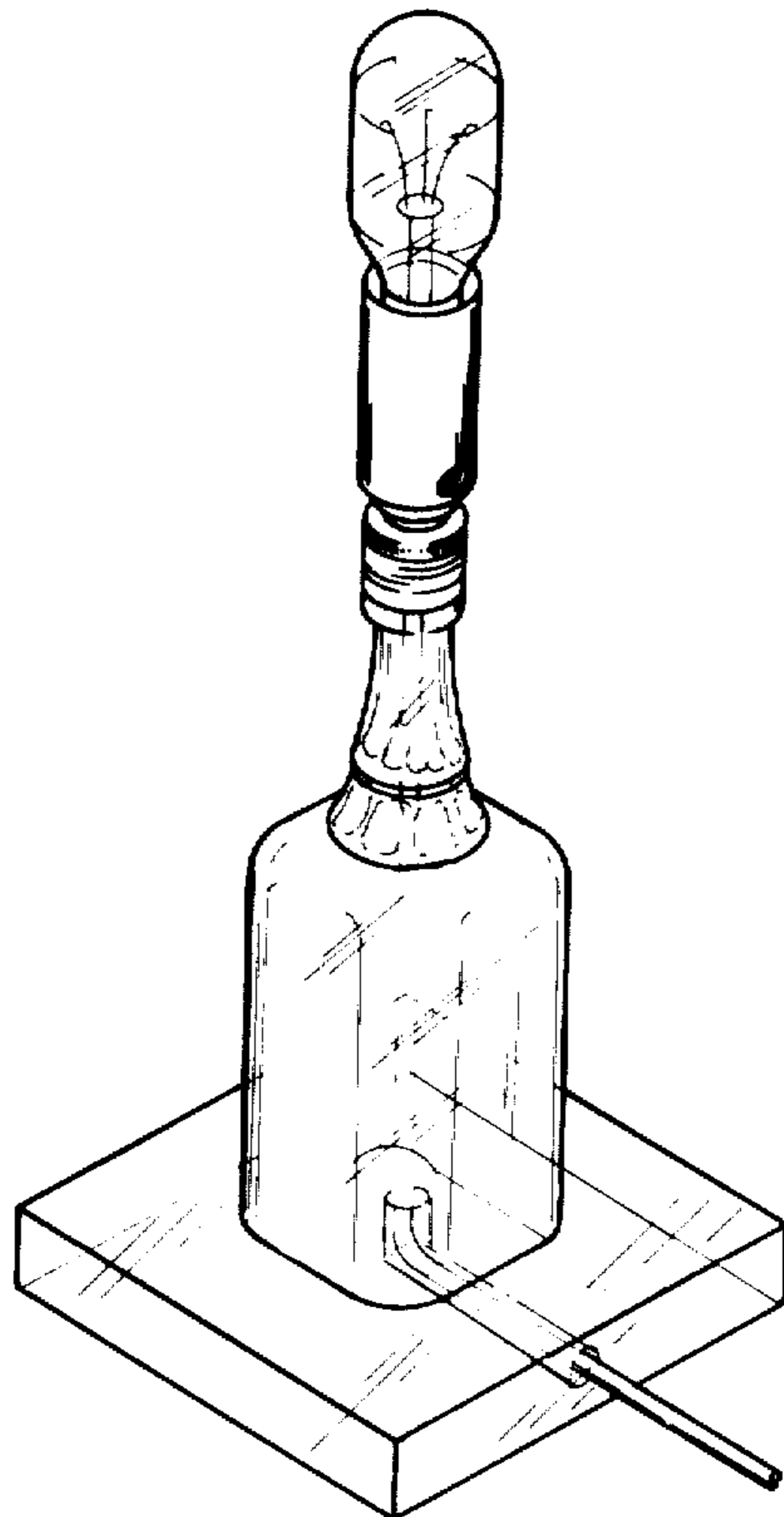

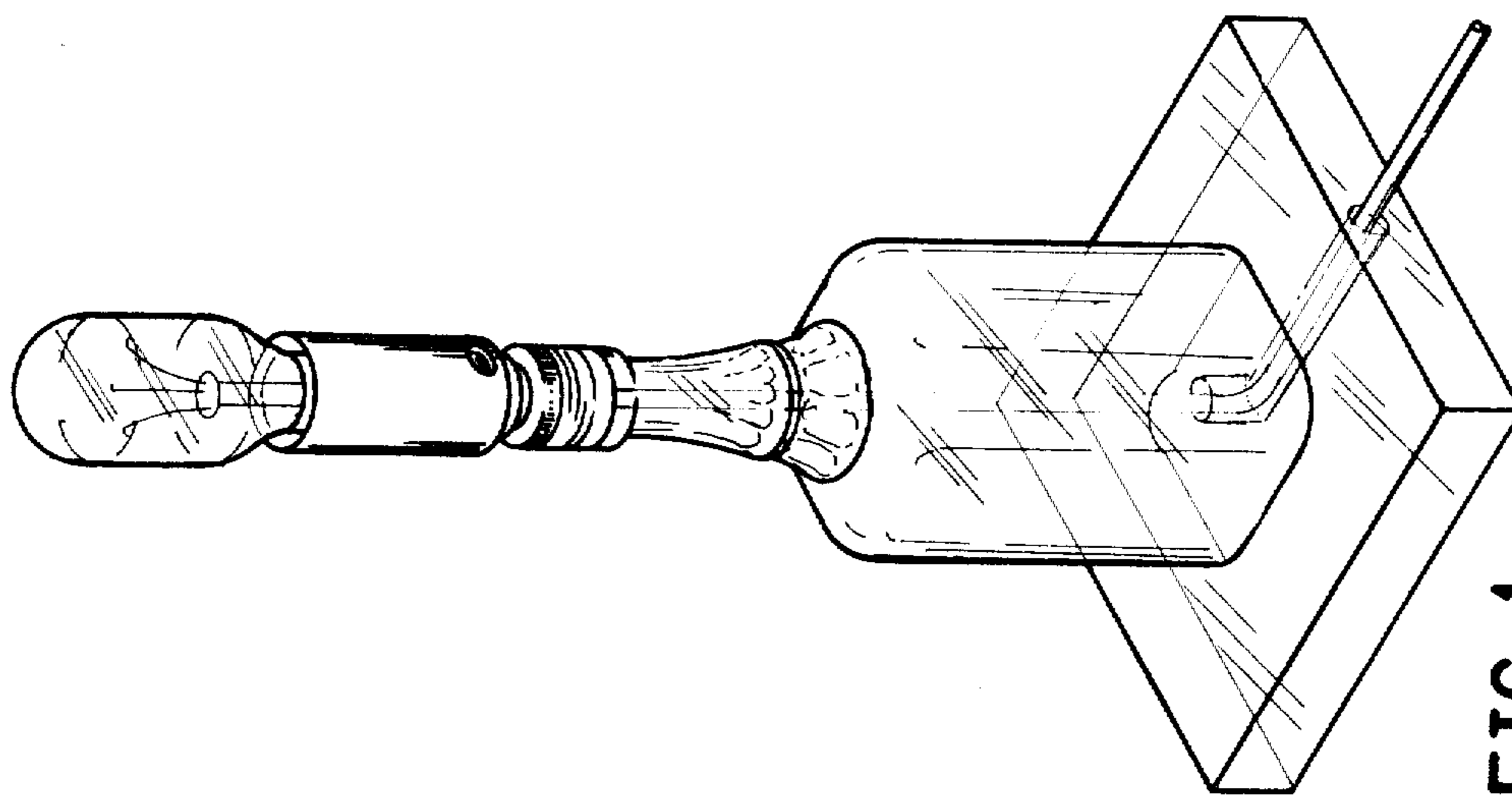

FIG. 1

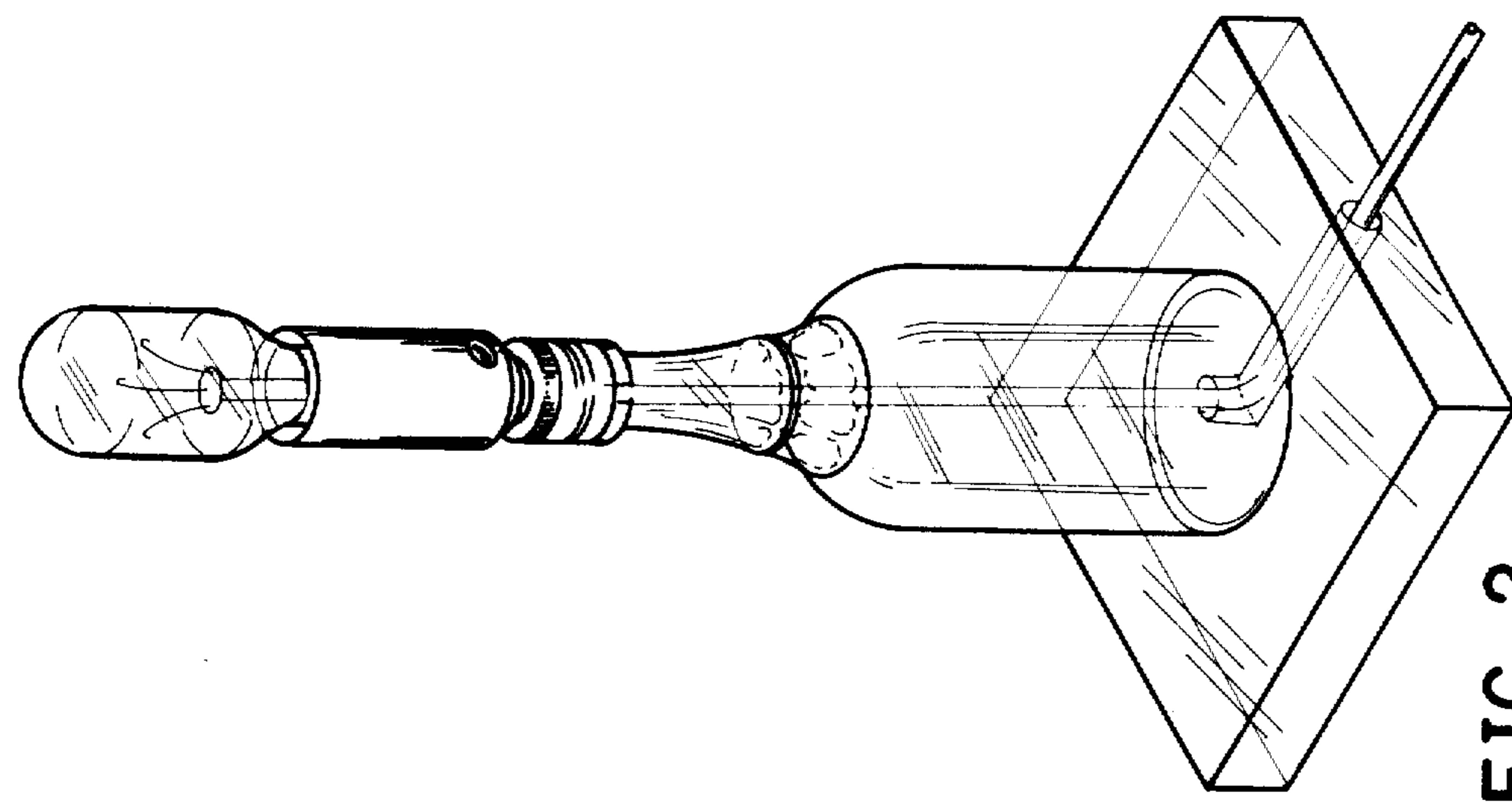

FIG. 2

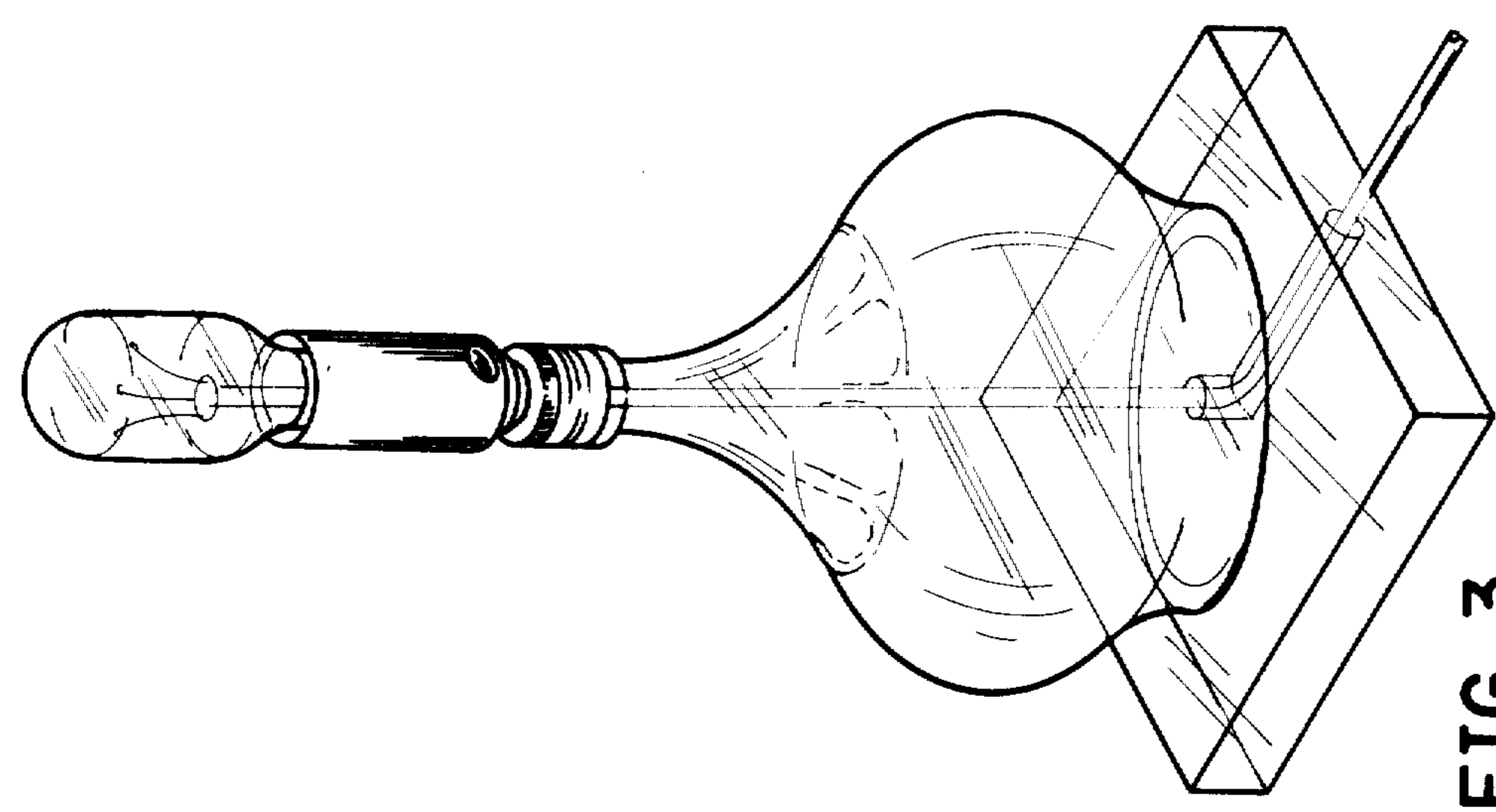

FIG. 3

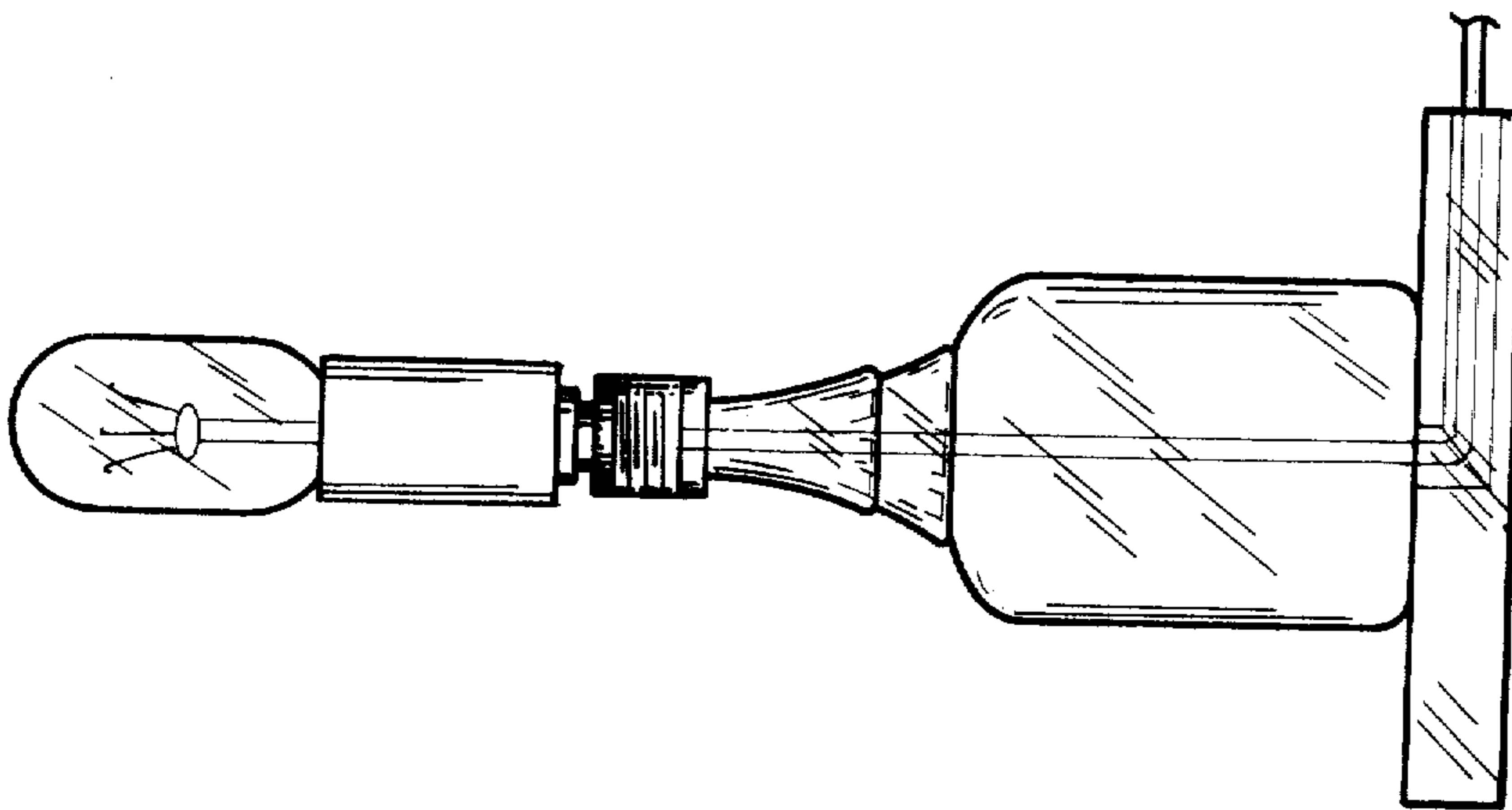

FIG. 4

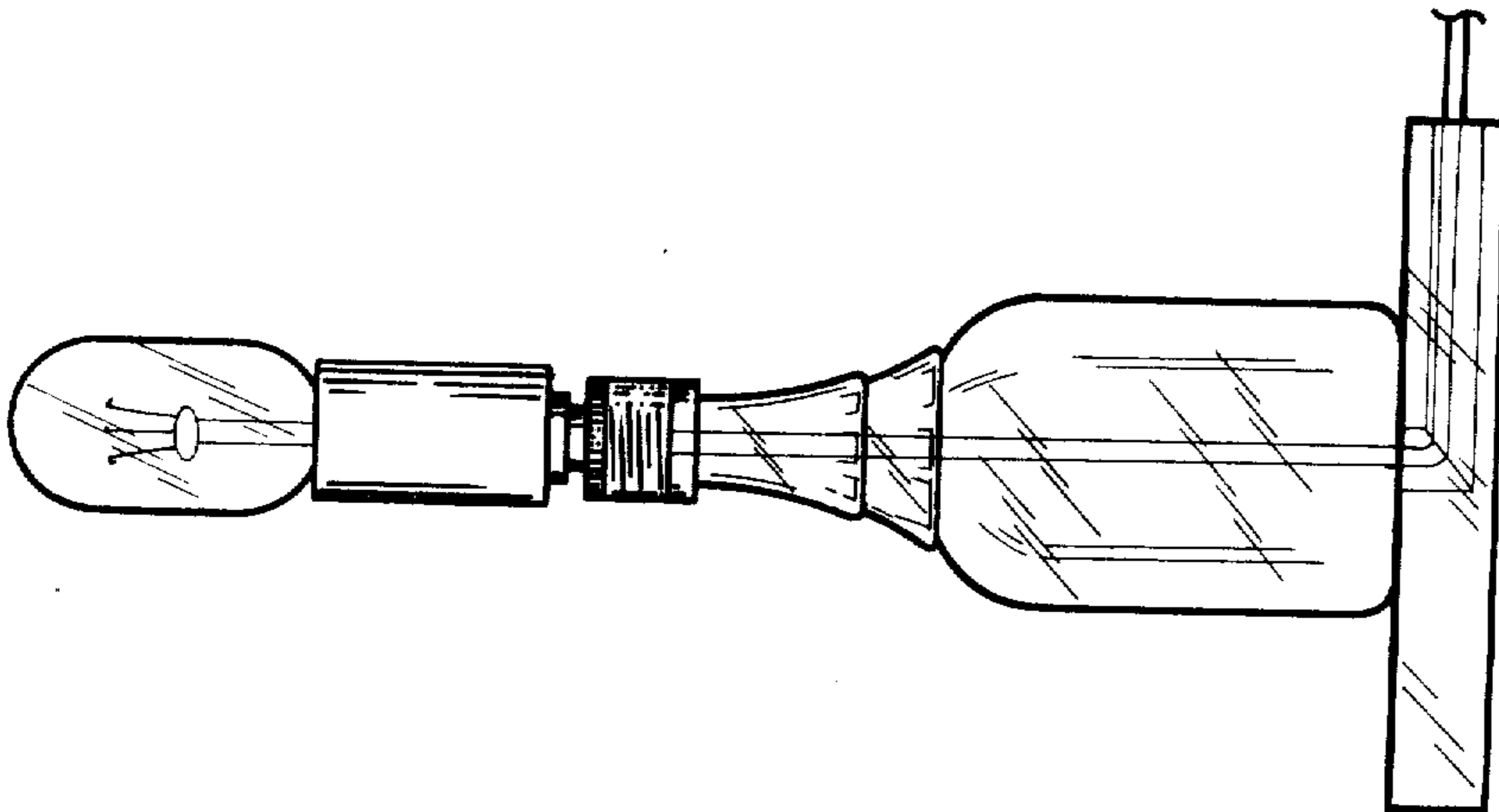

FIG. 5

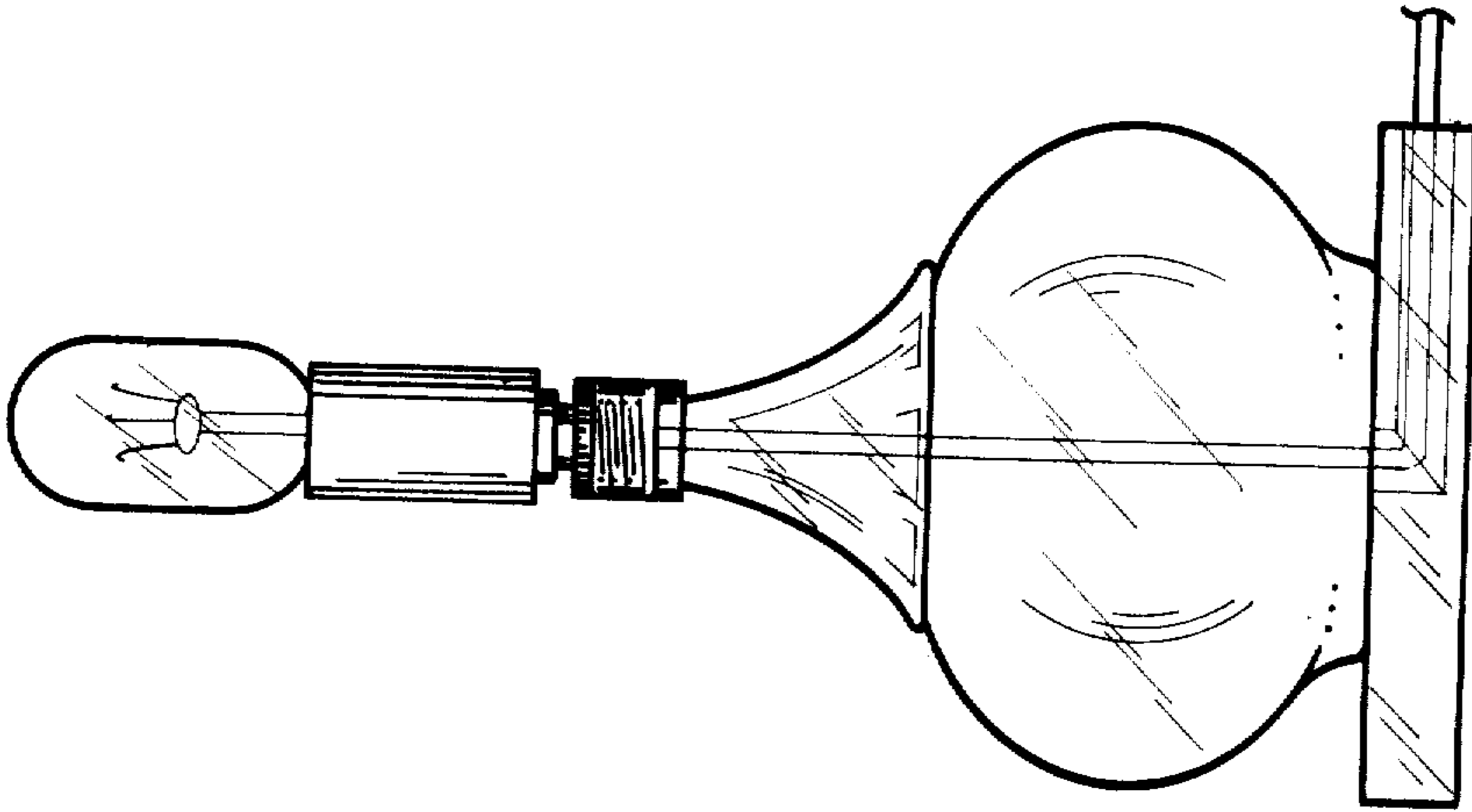

FIG. 6