

- [54] **LOCKING APPARATUS FOR SNOW SKIS AND THE LIKE**
- [75] Inventors: **Ronald A. Smith, Los Gatos; Johan R. P. Goudberg, San Jose, both of Calif.**
- [73] Assignee: **Apres Ski Partnership, San Jose, Calif.**
- [**] Term: **14 Years**
- [21] Appl. No.: **198,963**
- [22] Filed: **Oct. 20, 1980**
- [51] Int. Cl. **D8-07**
- [52] U.S. Cl. **D8/331; D8/334**
- [58] Field of Search **70/58, 19, 57; 280/814; D8/331, 333, 334, 343, 364**

References Cited

U.S. PATENT DOCUMENTS

- D. 249,633 9/1978 Sasaki **D8/331**
- 4,227,707 10/1980 Baker et al. **70/58 X**

*Primary Examiner—A. Hugo Word
Attorney, Agent, or Firm—Claude A. S. Hamrick*

[57] **CLAIM**

The ornamental design for a locking apparatus for snow skis and the like, substantially as shown and described.

DESCRIPTION

FIG. 1 is a perspective view illustrating both parts of a locking apparatus for snow skis and the like in accordance with our new design;

FIG. 2 is an elevational view thereof showing the lock and cam carrying portion beneath the cam engaging portion;

FIG. 3 is a top plan view of the lock and cam carrying part thereof;

FIG. 4 is a bottom plan view of the lock and cam carrying part thereof;

FIG. 5 is a top plan view of the cam engaging party thereof; and

FIG. 6 is a bottom plan view of the cam engaging part thereof.

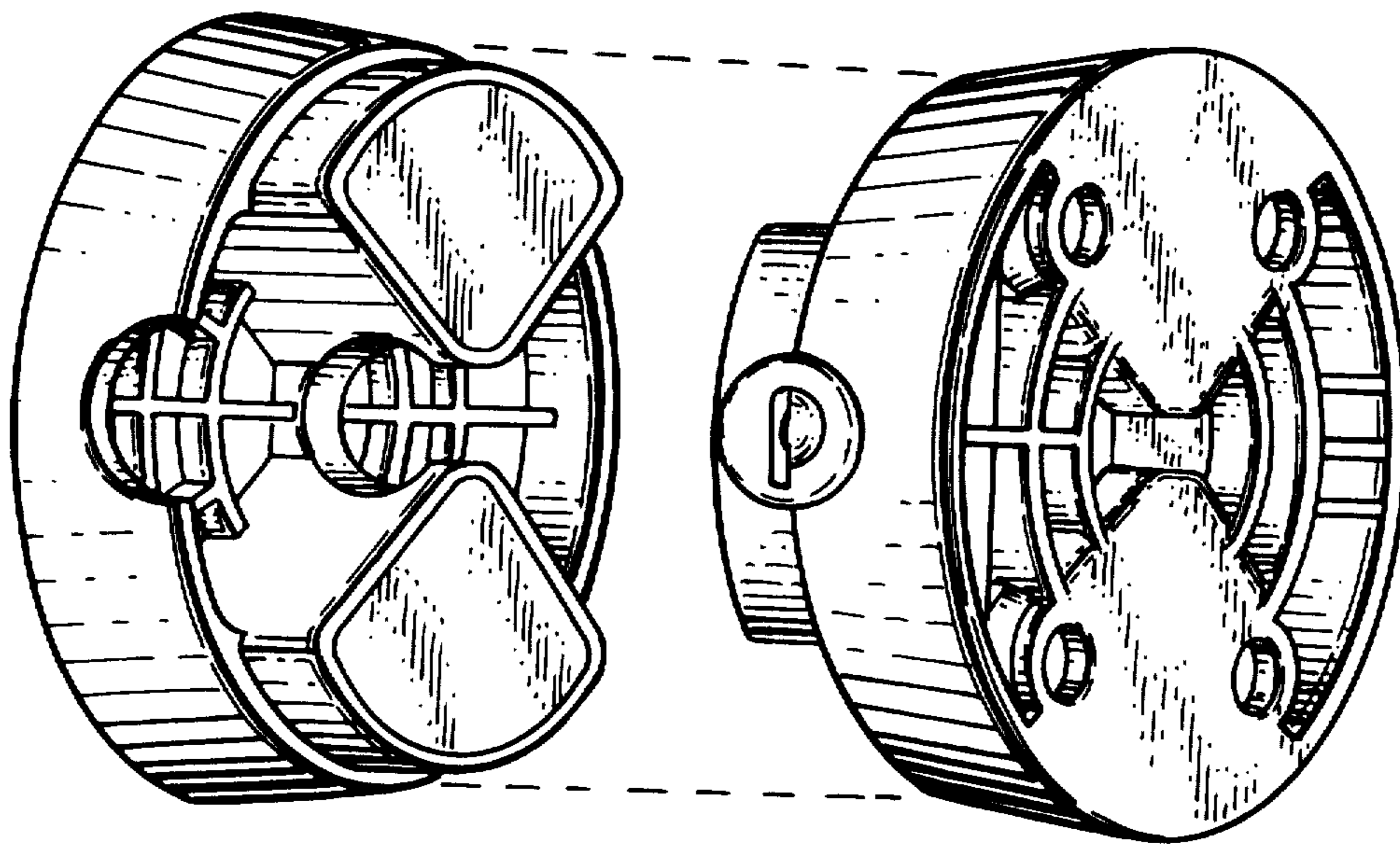

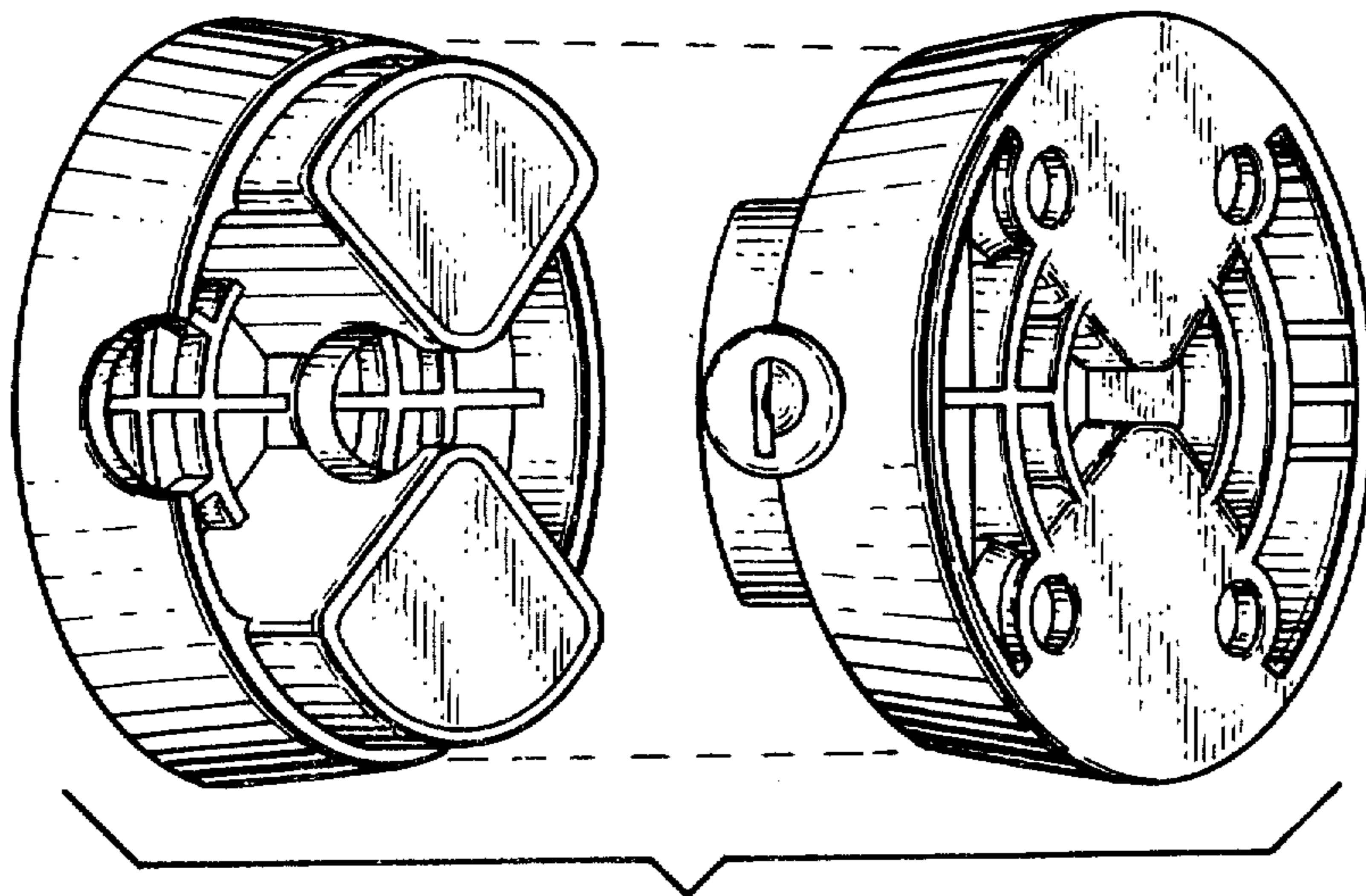

Fig-1

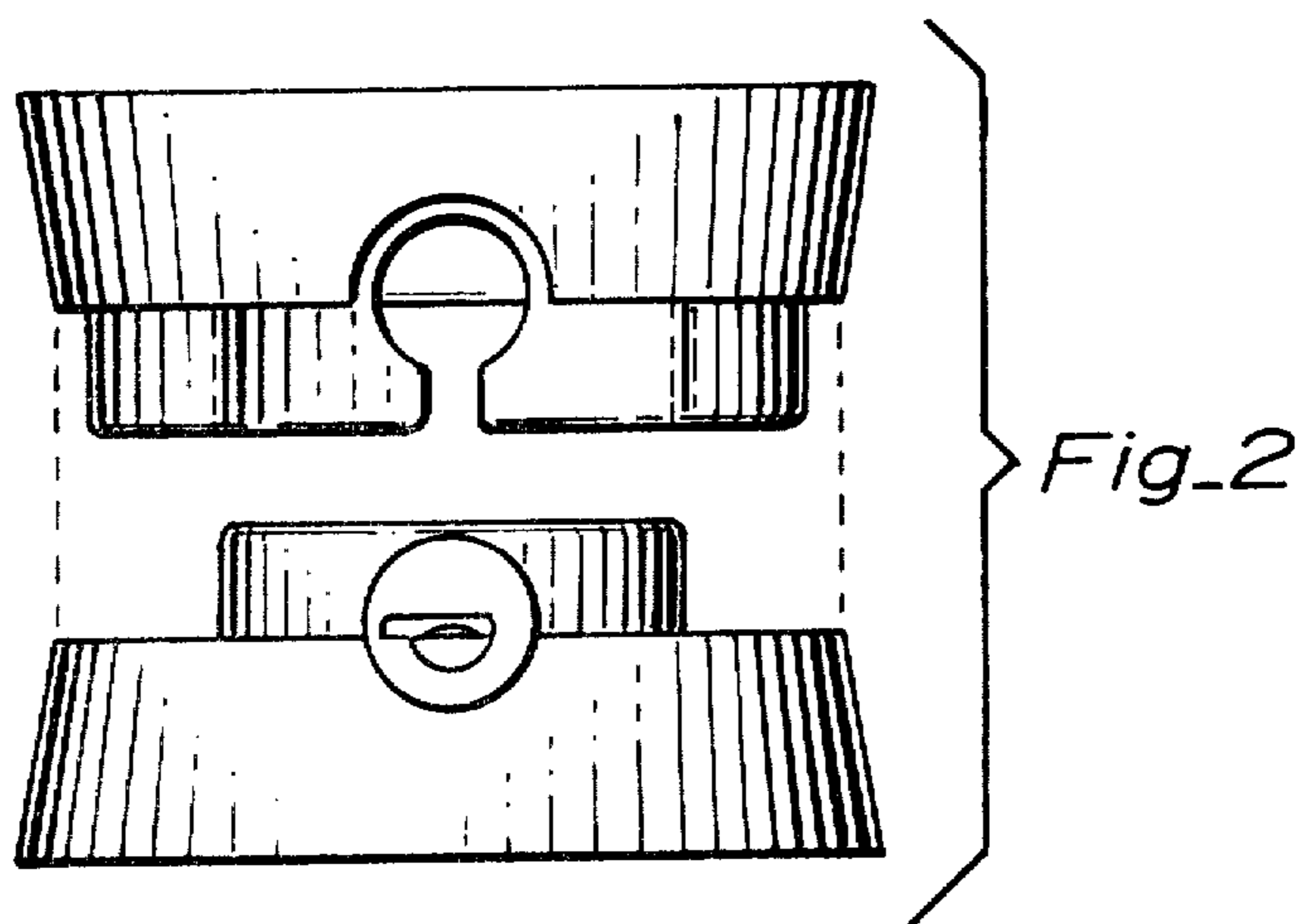
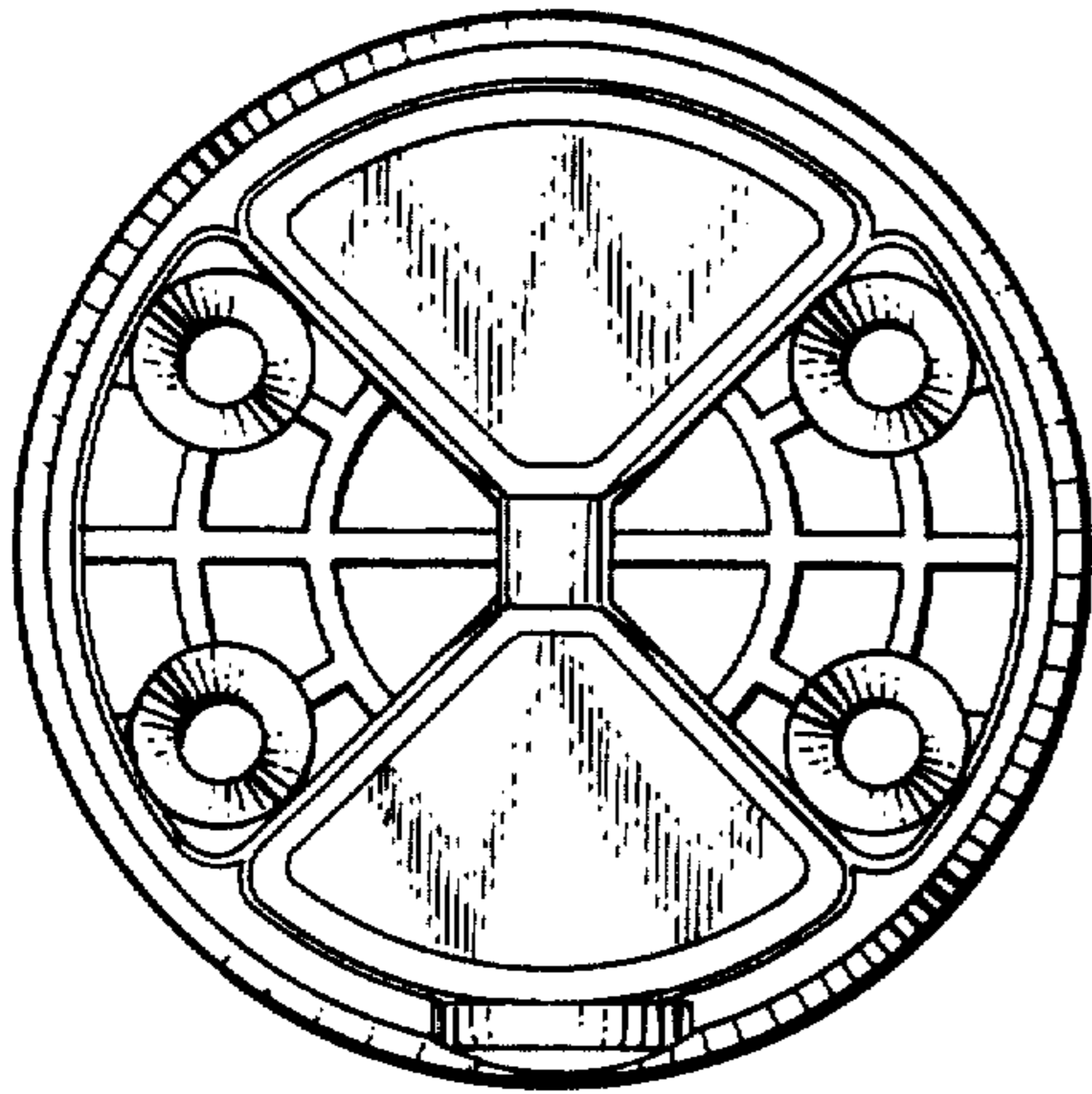
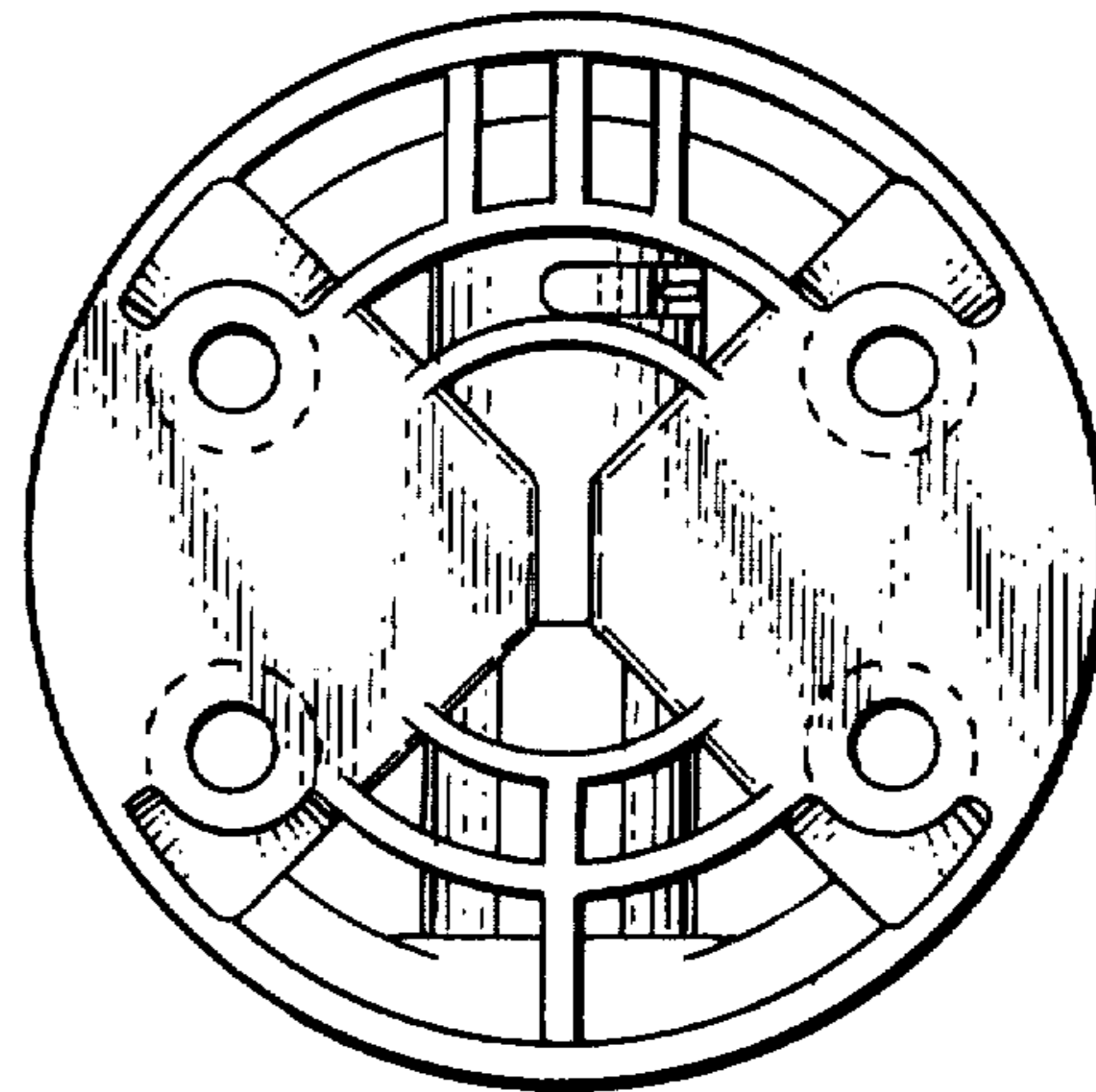

Fig-2



Fig_3



Fig_4

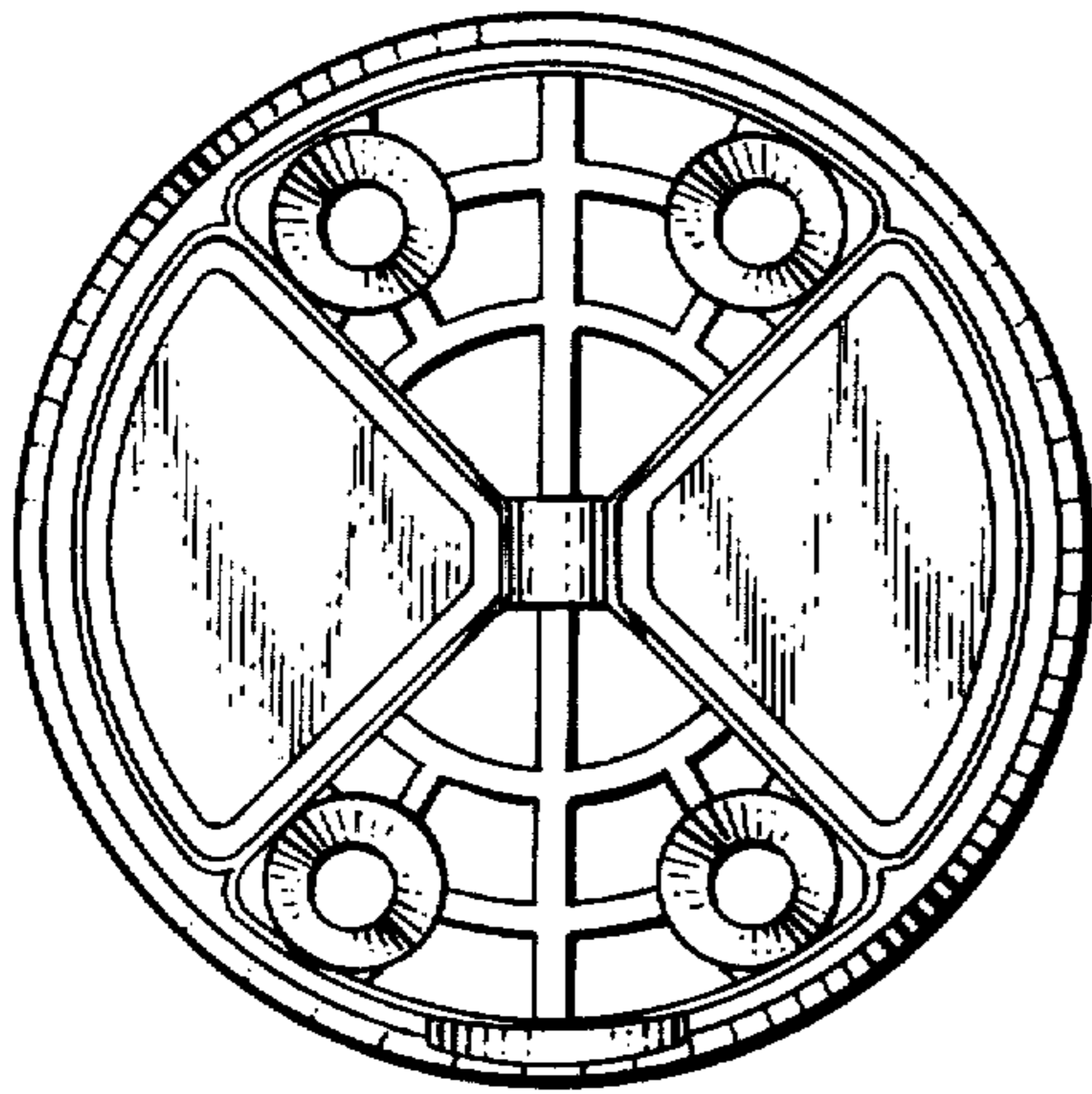

Fig_5

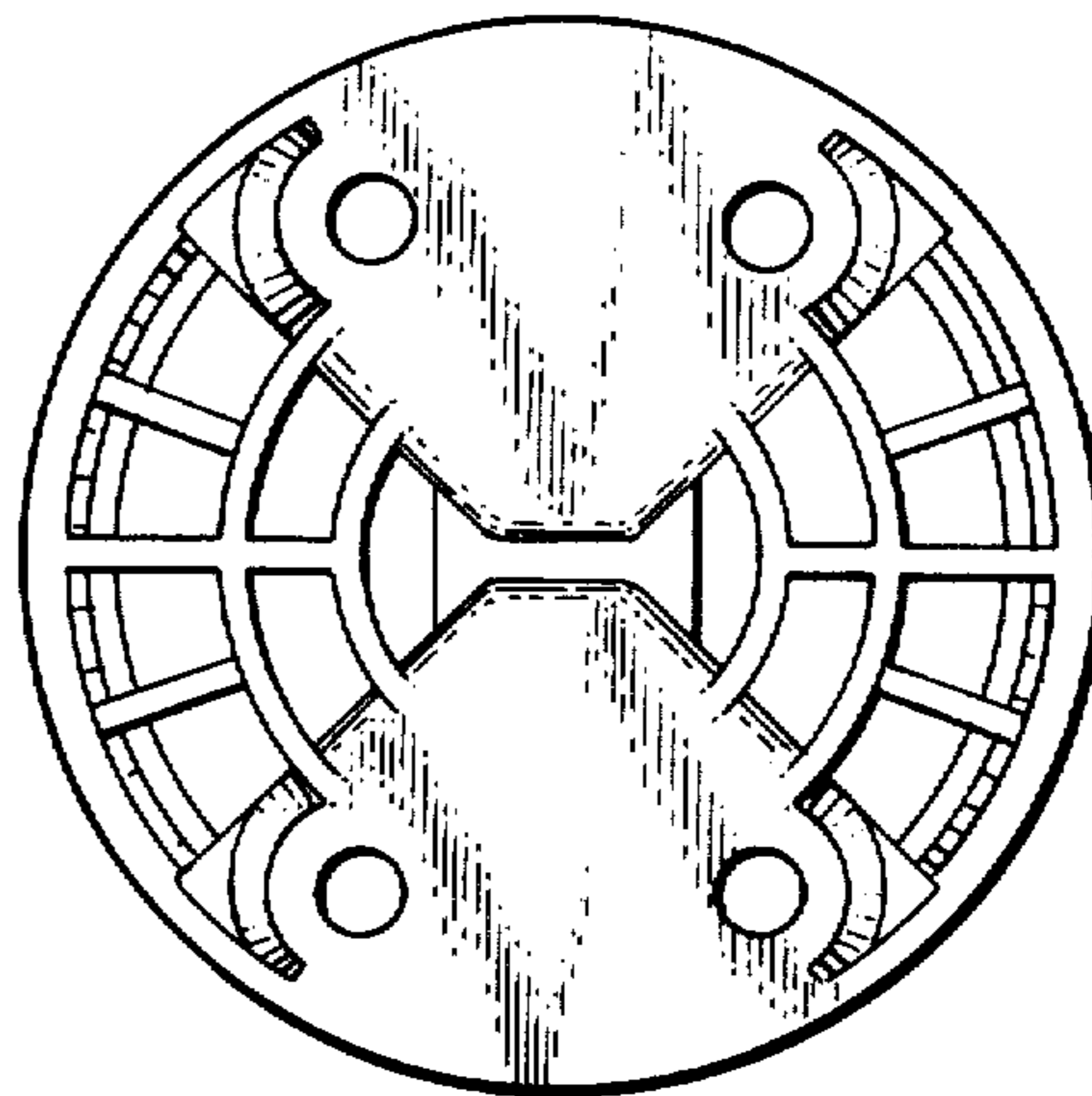

Fig_6