

[54] AIRCRAFT

[75] Inventors: Abraham Enav, Elmont; Gordon Rosenthal, Jericho, both of N.Y.

[73] Assignee: Fairchild Industries, Inc., Germantown, Md.

[\*\*] Term: 14 Years

[21] Appl. No.: 143,672

[22] Filed: Apr. 25, 1980

[51] Int. Cl. .... D12-07

[52] U.S. Cl. .... D12/331

[58] Field of Search ..... D12/331, 343, 333; 244/45 R, 45 A

[56] References Cited

U.S. PATENT DOCUMENTS

- 4,053,125 10/1977 Ratony ..... 244/45 R
- 4,090,681 5/1978 Zimmer ..... 244/45 R

OTHER PUBLICATIONS

Interavia, 7/79, p. 629, Aircraft shown in box 7, bottom right side of page.

Primary Examiner—James M. Gandy  
Attorney, Agent, or Firm—Michael W. York

[57] CLAIM

The ornamental design for an aircraft, substantially as shown and described.

DESCRIPTION

FIG. 1 is a top plan view of an aircraft showing our new design;

FIG. 2 is a front elevational view thereof;

FIG. 3 is an elevational view of one side thereof, the elevational view of the other side being substantially a mirror image of the side shown;

FIG. 4 is a bottom plan view thereof; and

FIG. 5 is an elevational view of the rear thereof.

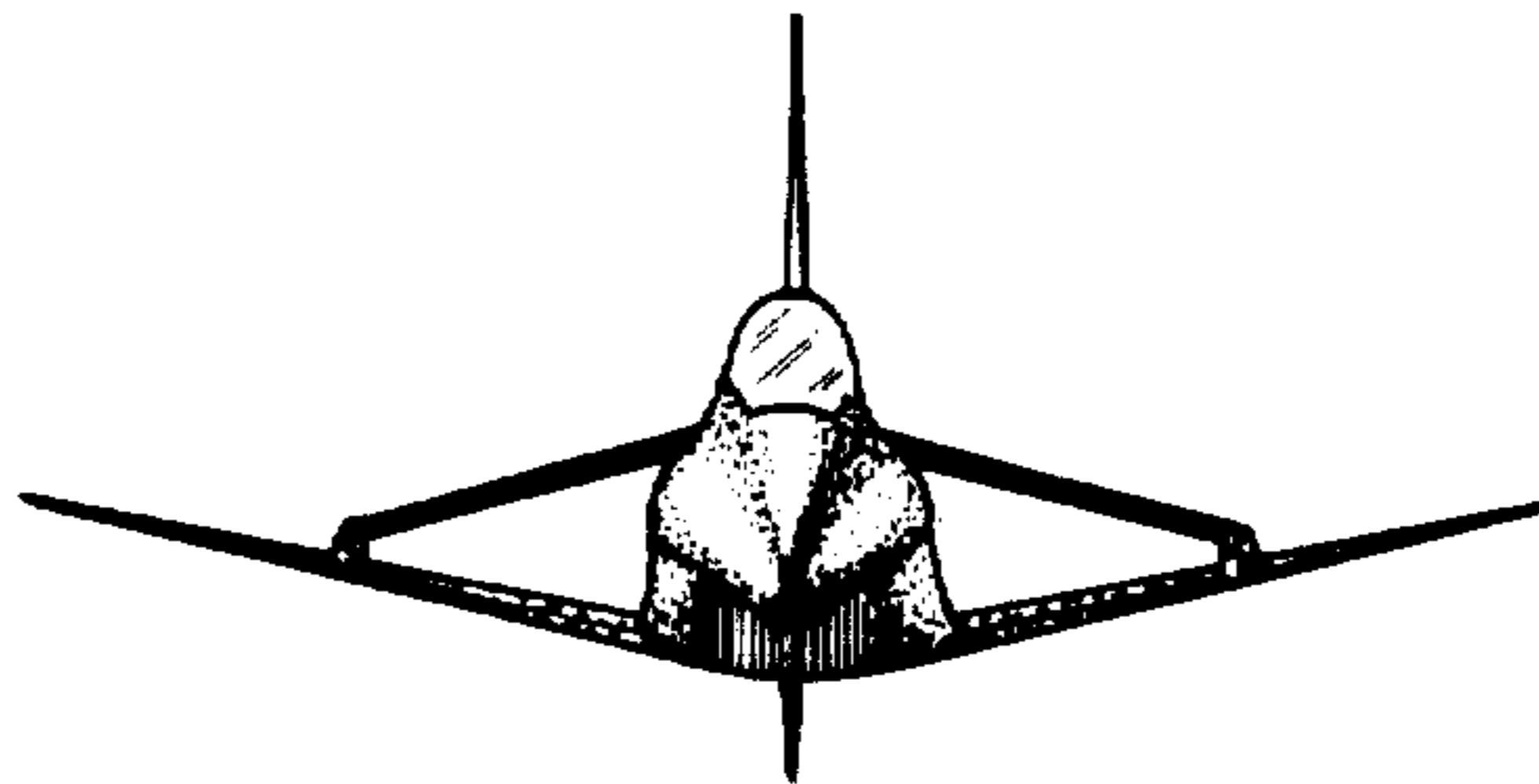
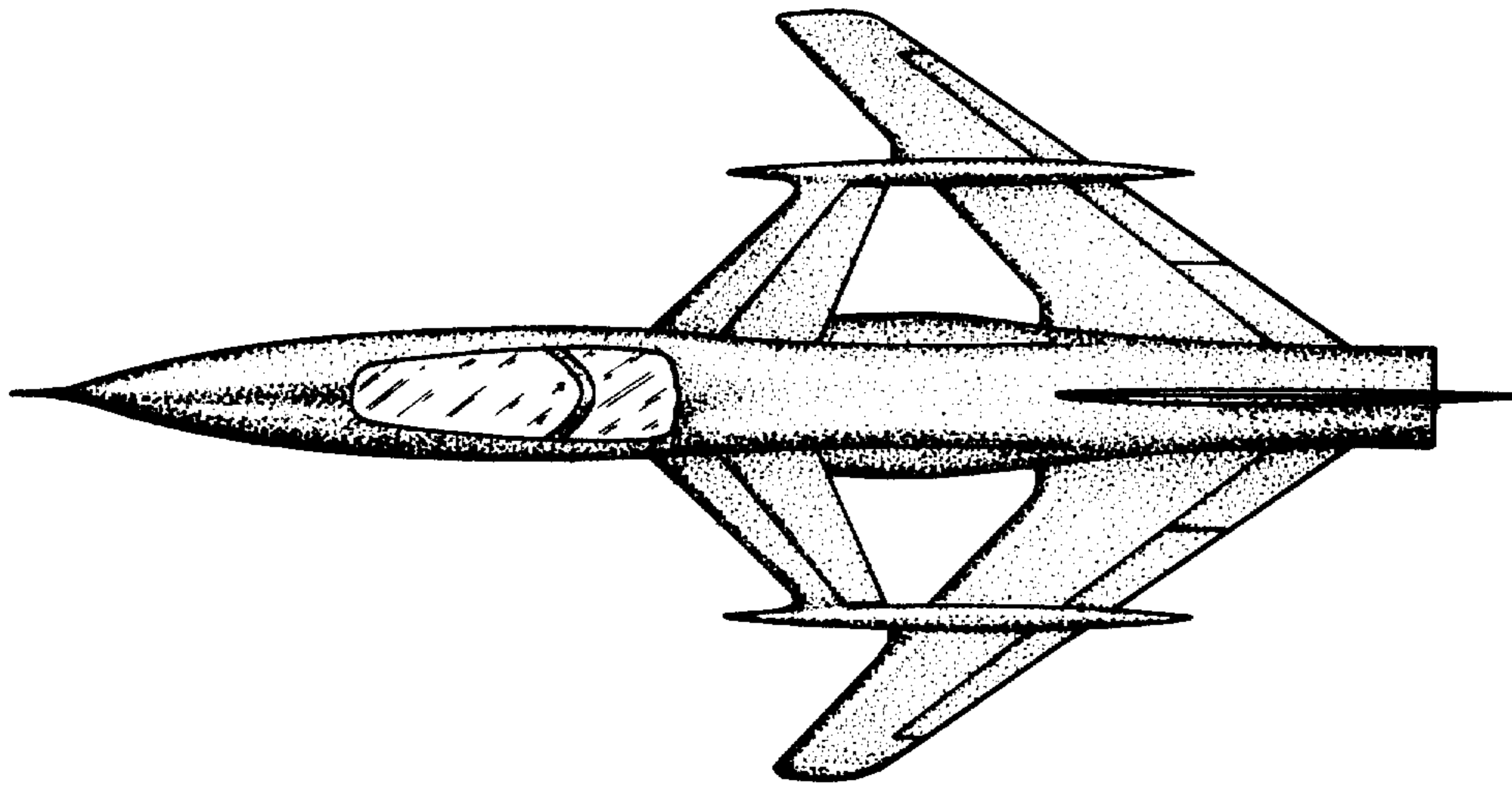

Fig. 1

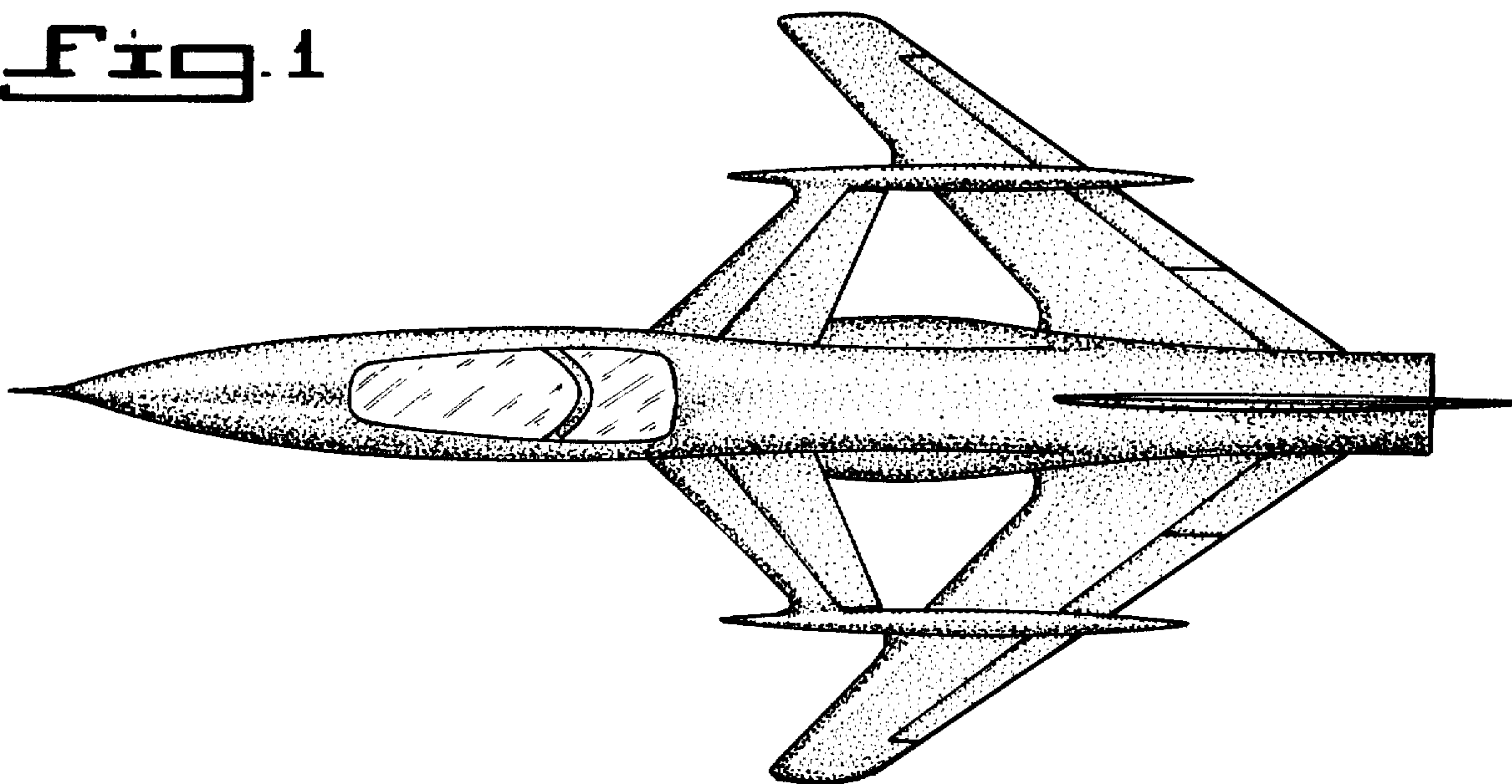

Fig. 2

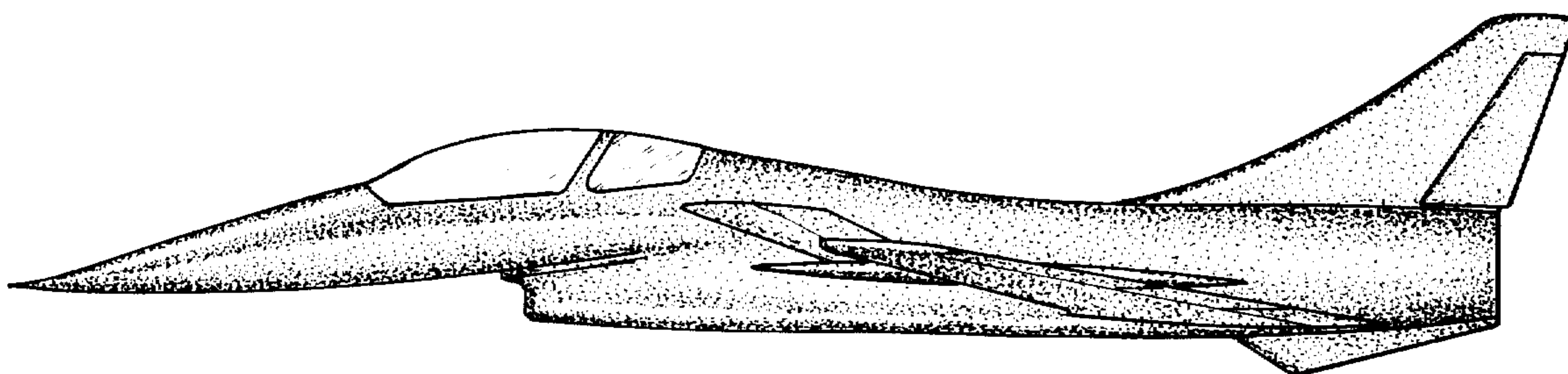
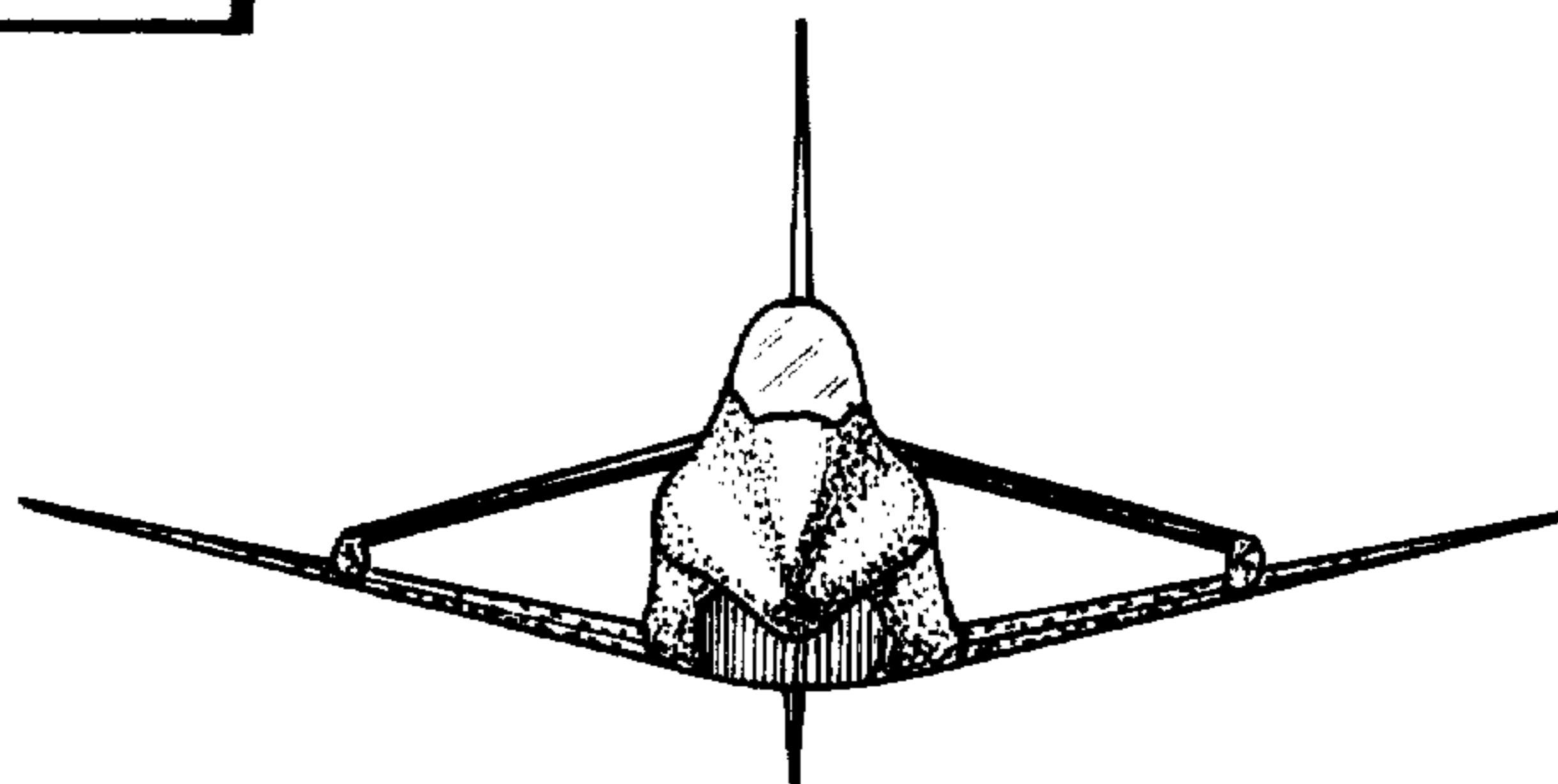

Fig. 3

Fig. 4

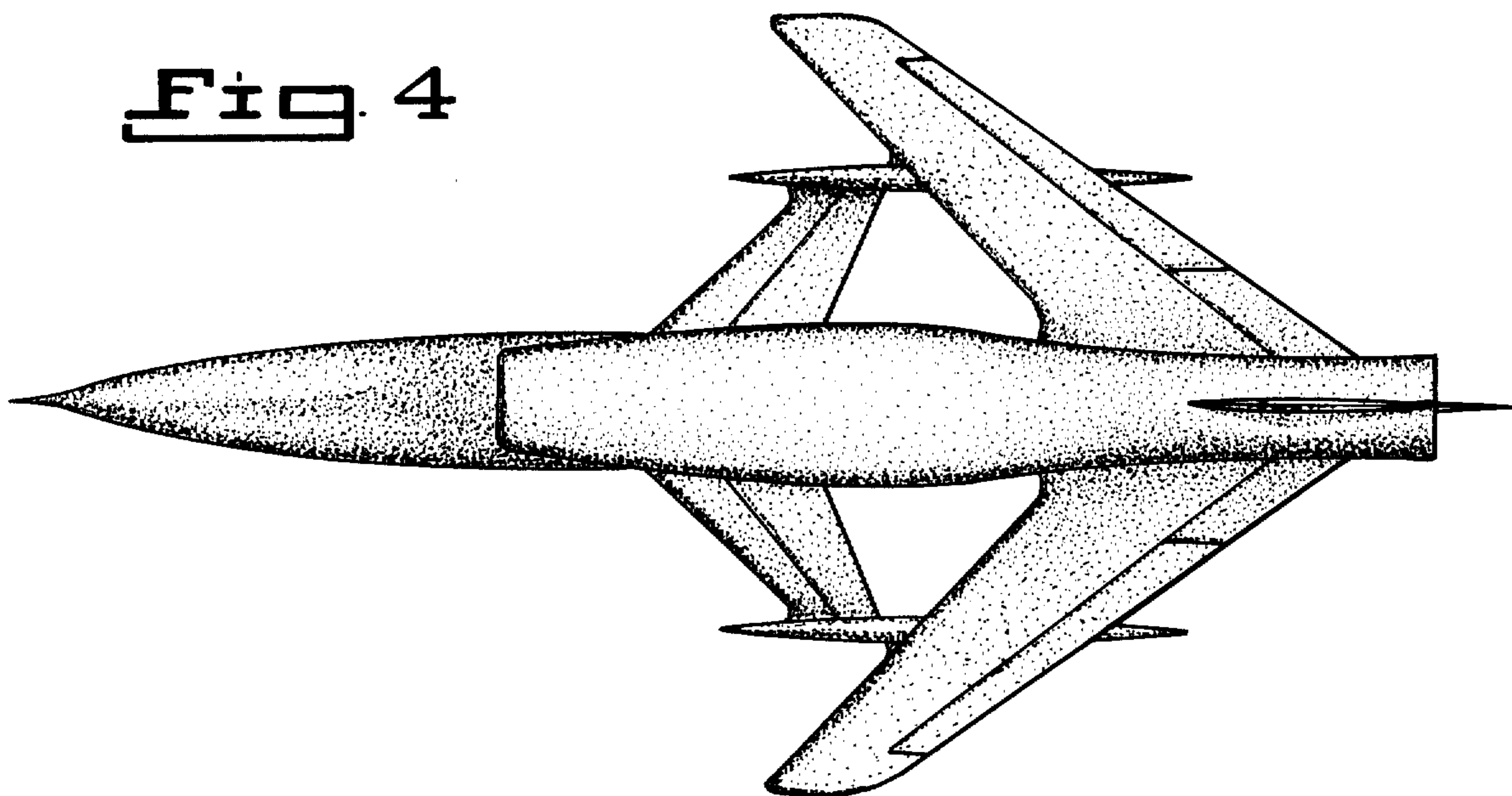

Fig. 5

