

[54] MARITIME MAINTENANCE VESSEL OR THE LIKE

[76] Inventors: **Jerrold C. Feiger**, 11820 Mayfield Ave., Los Angeles, Calif. 90049; **Ben Braunstein**, 1102 Raintree Cir., Culver City, Calif. 90230

[**] Term: **14 Years**

[21] Appl. No.: **54,279**

[22] Filed: **Jul. 2, 1979**

[51] Int. Cl. **D12-06**

[52] U.S. Cl. **D12/310; D12/316; D12/300**

[58] Field of Search **D12/62, 300, 310-312, D12/316; 114/56, 61, 283, 288, 292, 26, 242**

[56]

References Cited

U.S. PATENT DOCUMENTS

D. 206,505	12/1966	Schindler	D12/62
3,584,590	6/1971	Rings et al.	114/61
3,665,885	5/1972	Javes	114/61
3,822,661	7/1974	Simpson	114/56
3,942,457	3/1976	Keyes et al.	114/61

Primary Examiner—T. Tung
Attorney, Agent, or Firm—Cislo, O'Reilly & Thomas

[57]

CLAIM

The ornamental design for a maritime maintenance vessel or the like, as shown and described.

DESCRIPTION

FIG. 1 is a front view of the maritime maintenance vessel or the like;
FIG. 2 is a left side, elevational view thereof;
FIG. 3 is a right side, elevational view thereof;
FIG. 4 is a rear view thereof;
FIG. 5 is a top view thereof; and
FIG. 6 is a bottom view thereof.

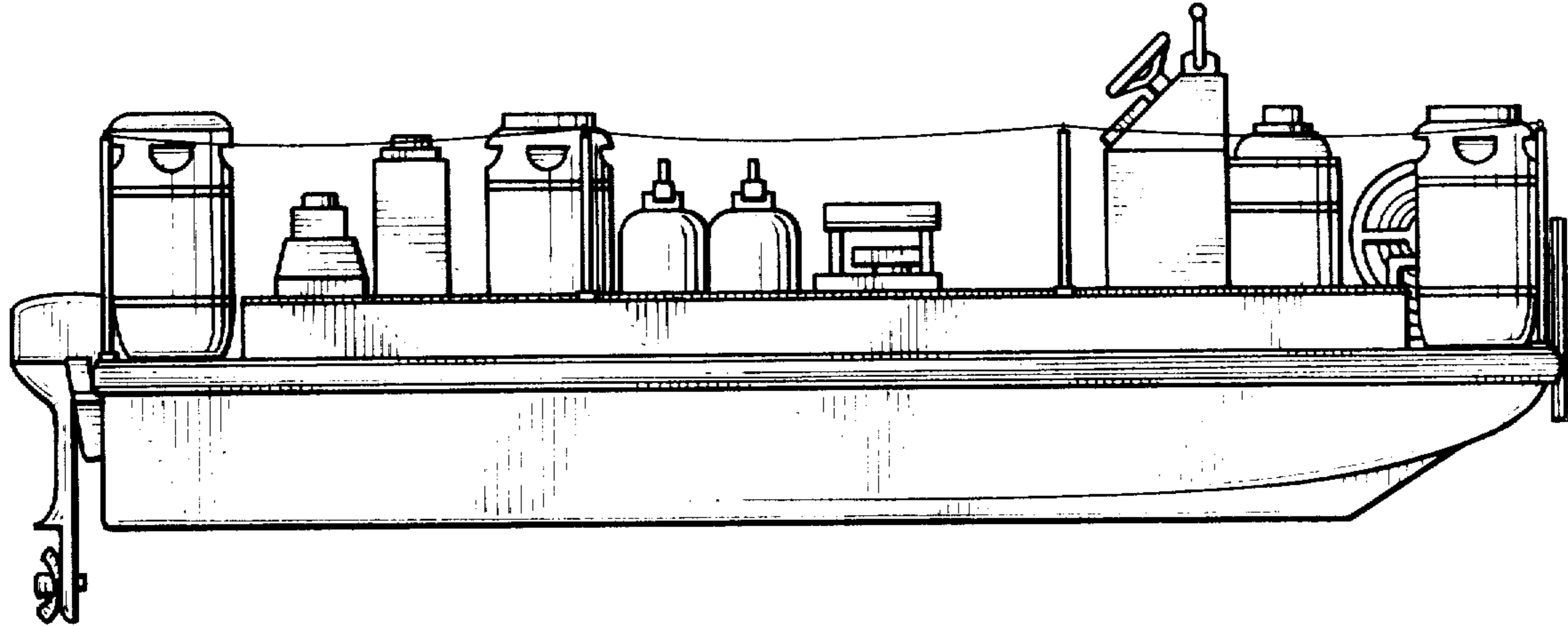

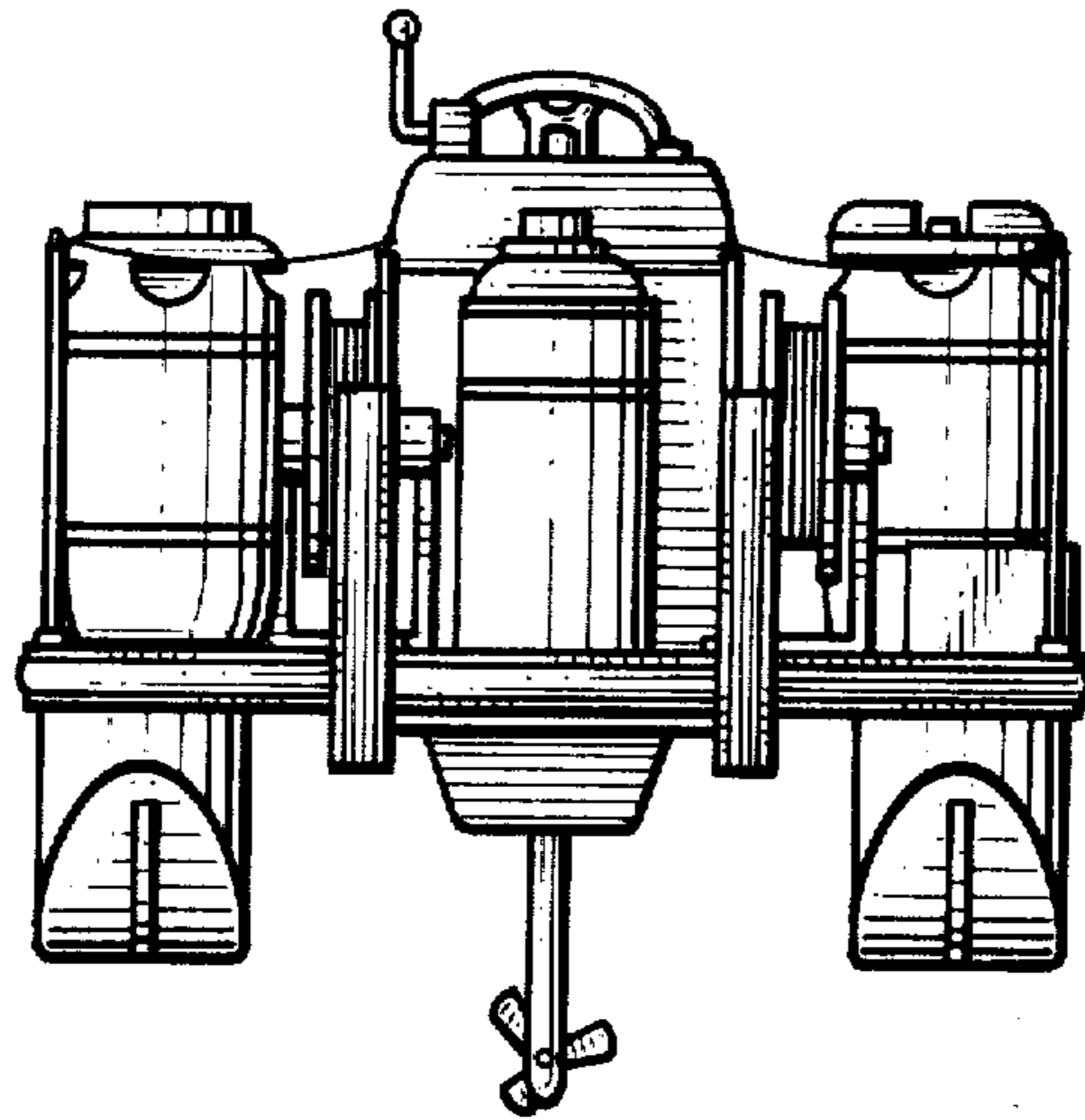

Fig. 1.

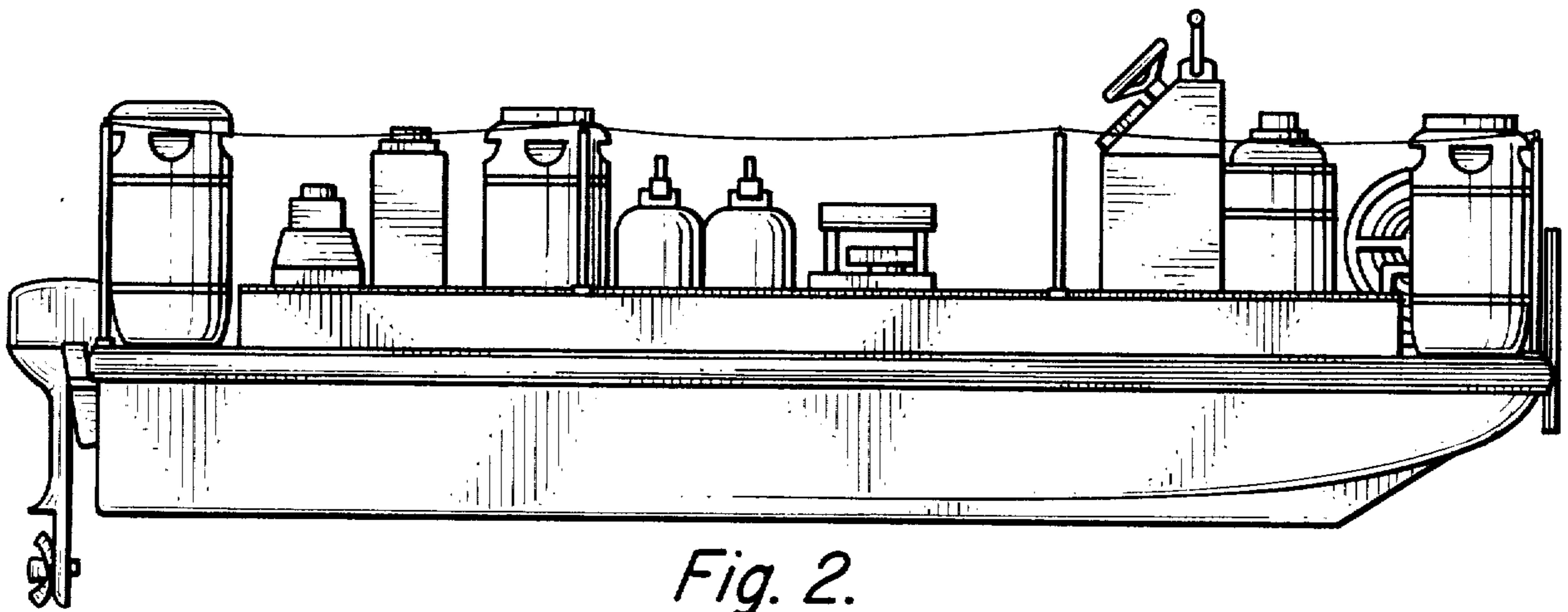

Fig. 2.

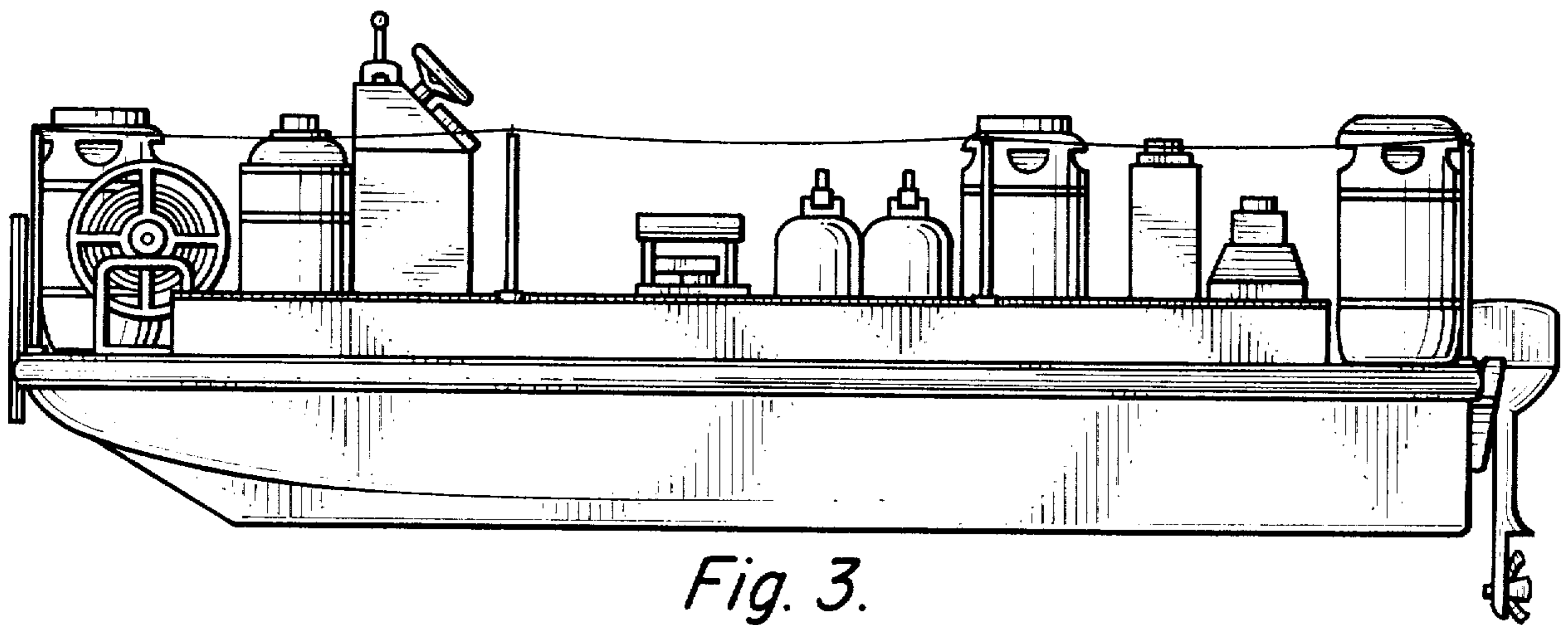

Fig. 3.

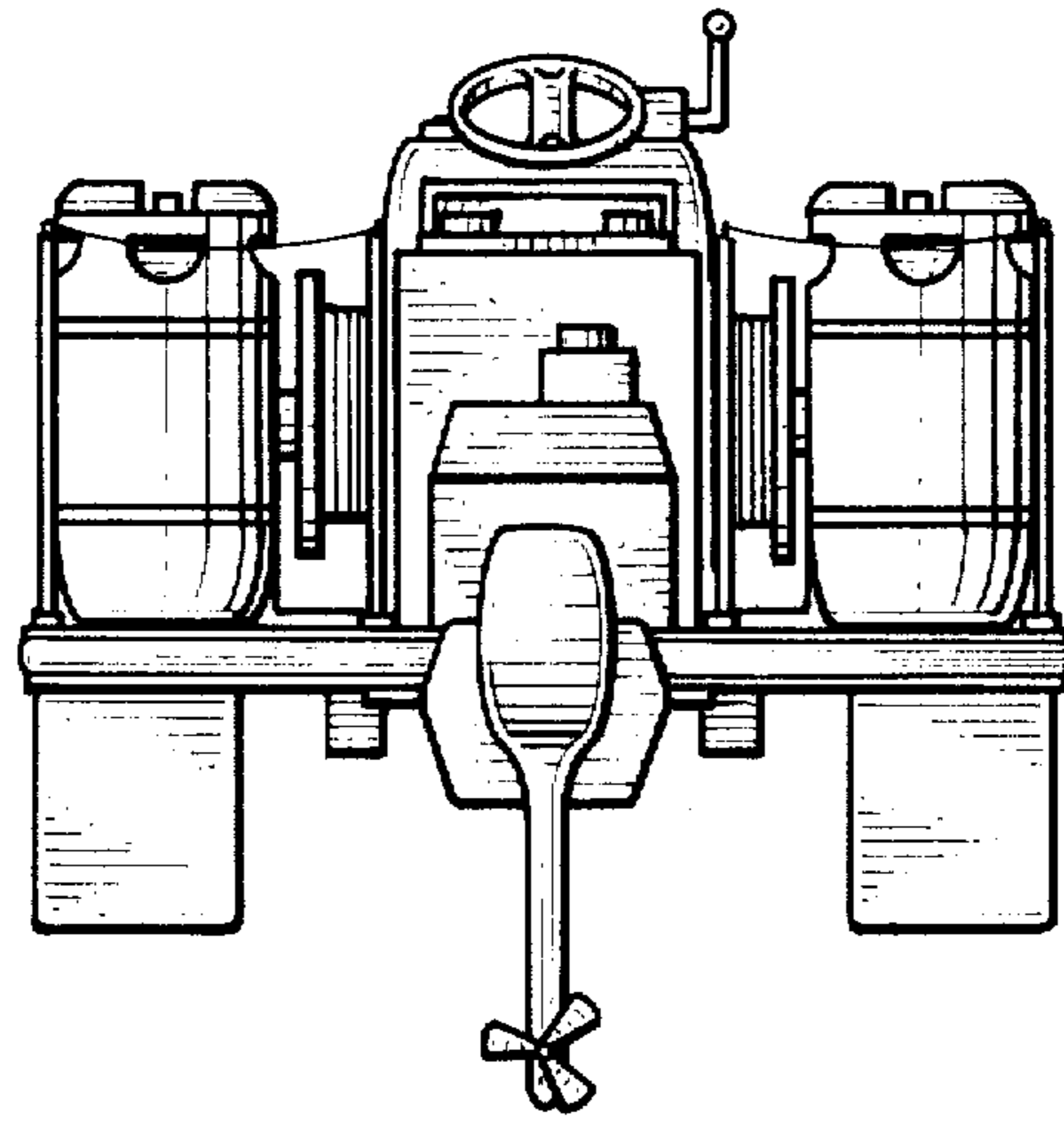

Fig. 4.

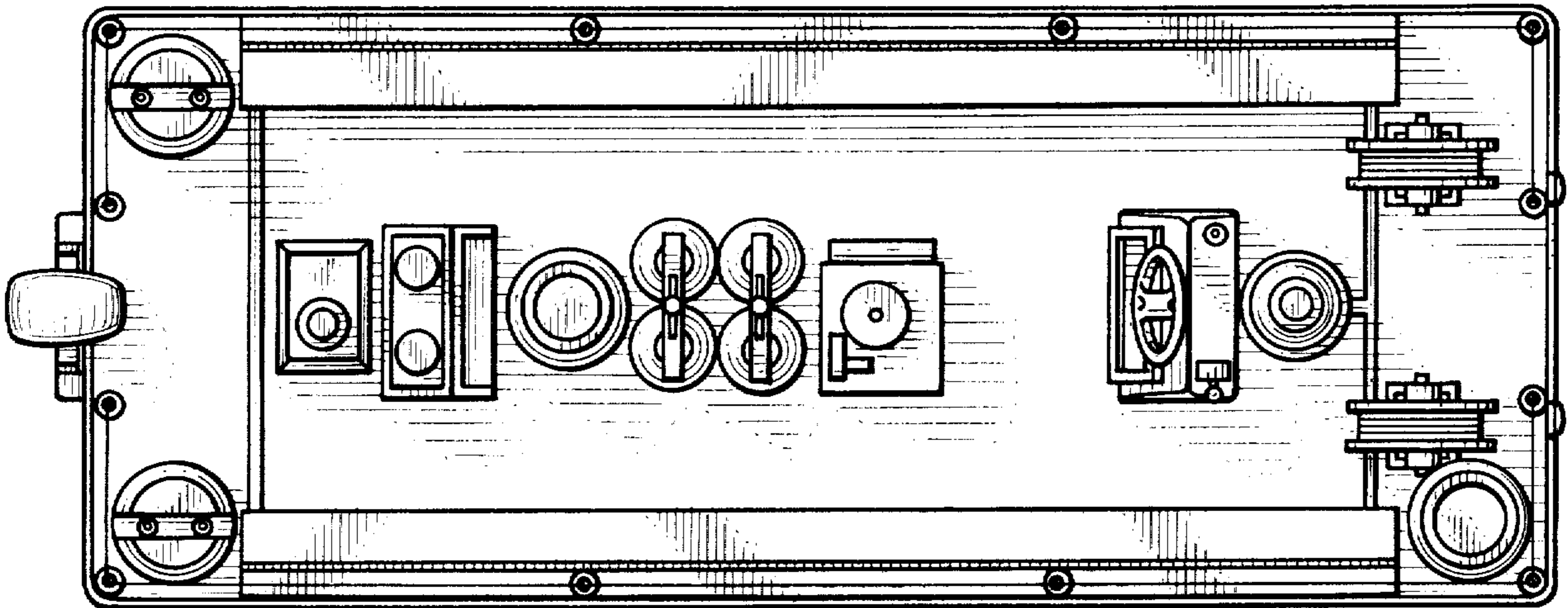

Fig. 5.

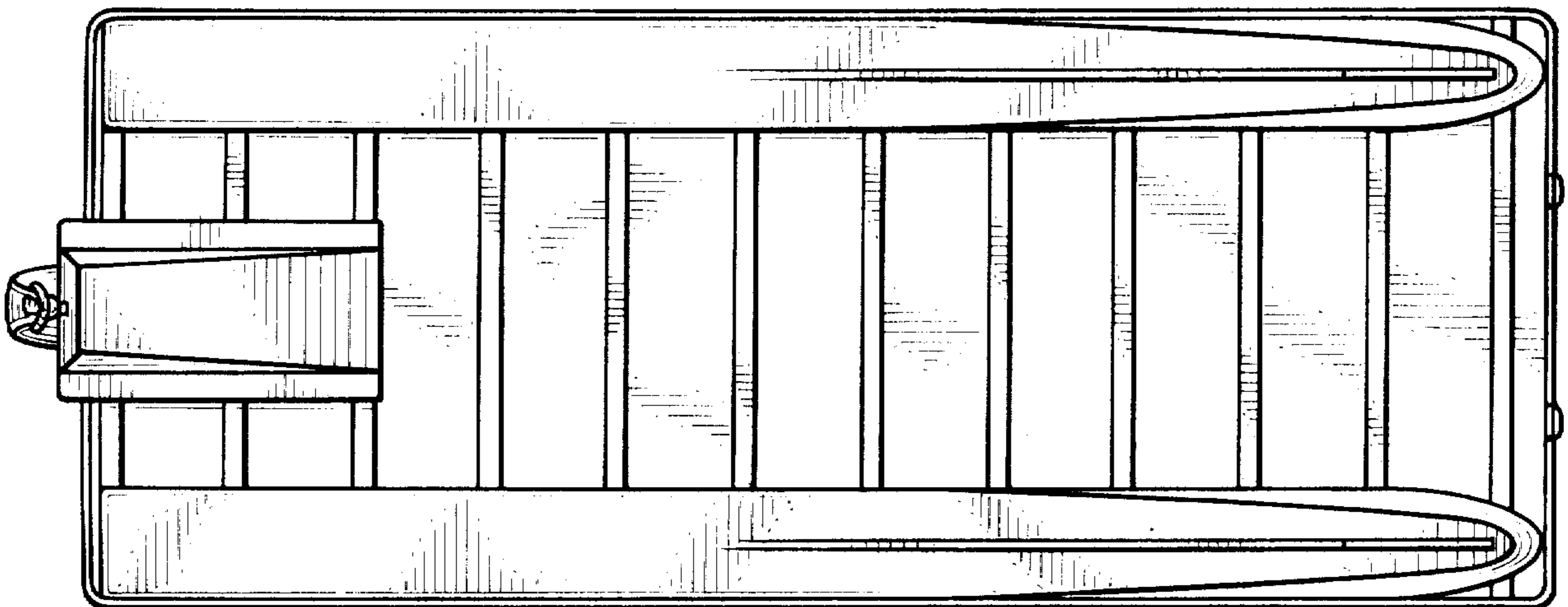

Fig. 6.