

[54] COMBINATION BOAT, CAMPER, AND UTILITY TRAILER

[76] Inventors: Owen H. Pope, 163 Lincoln St.; David W. Gibbard, 2519 Bowers Rd., both of Lapeer, Mich. 48446

[**] Term: 14 Years

[21] Appl. No.: 140,106

[22] Filed: Apr. 14, 1980

[51] Int. Cl. D12-10

[52] U.S. Cl. D12/104; D12/102; D12/3

[58] Field of Search D12/102, 104, 3; 296/157, 159, 161, 168, 172, 173, 181; 280/656, 414 R

[56] References Cited

U.S. PATENT DOCUMENTS

D. 231,917 6/1974 Nozaki et al. D12/102

FOREIGN PATENT DOCUMENTS

7702081 9/1978 France 296/168

Primary Examiner—James M. Gandy

[57] CLAIM

The ornamental design for a combined boat, camper and utility trailer, substantially as shown and described.

DESCRIPTION

FIG. 1 is a perspective view of a combined boat, camper, and utility trailer embodying this invention; FIG. 2 is a top plan view thereof; FIG. 3 is a right side elevational view thereof, the left side being substantially a mirror image of the right side shown; FIG. 4 is an enlarged rear elevational view thereof; FIG. 5 is an enlarged front elevational view thereof; FIG. 6 is a perspective view thereof in open condition with the boat removed and the bed board and tent set up for use as a camper; FIG. 7 is a left side elevational view of FIG. 6; FIG. 8 is a rear elevational view of FIG. 6; FIG. 9 is a front elevational view of FIG. 6; FIG. 10 is a right side elevational view of FIG. 6; FIG. 11 is a top plan view of the boat of the invention turned upright; FIG. 12 is a bottom plan view of FIG. 11; FIG. 13 is an enlarged left side elevational view of FIG. 11; FIG. 14 is an enlarged rear elevational view of FIG. 11; FIG. 15 is an enlarged front elevational view of FIG. 11; FIG. 16 is a top plan view of the trailer of the invention with the boat and bed board and tent removed; FIG. 17 is a bottom plan view of FIG. 16; FIG. 18 is a right side elevational view of FIG. 16; FIG. 19 is an enlarged rear elevational view of FIG. 16; and FIG. 20 is an enlarged front elevational view of FIG. 16. The broken lines on the tent in FIGS. 6, 7, 8, 9 and 10 represent stitching.

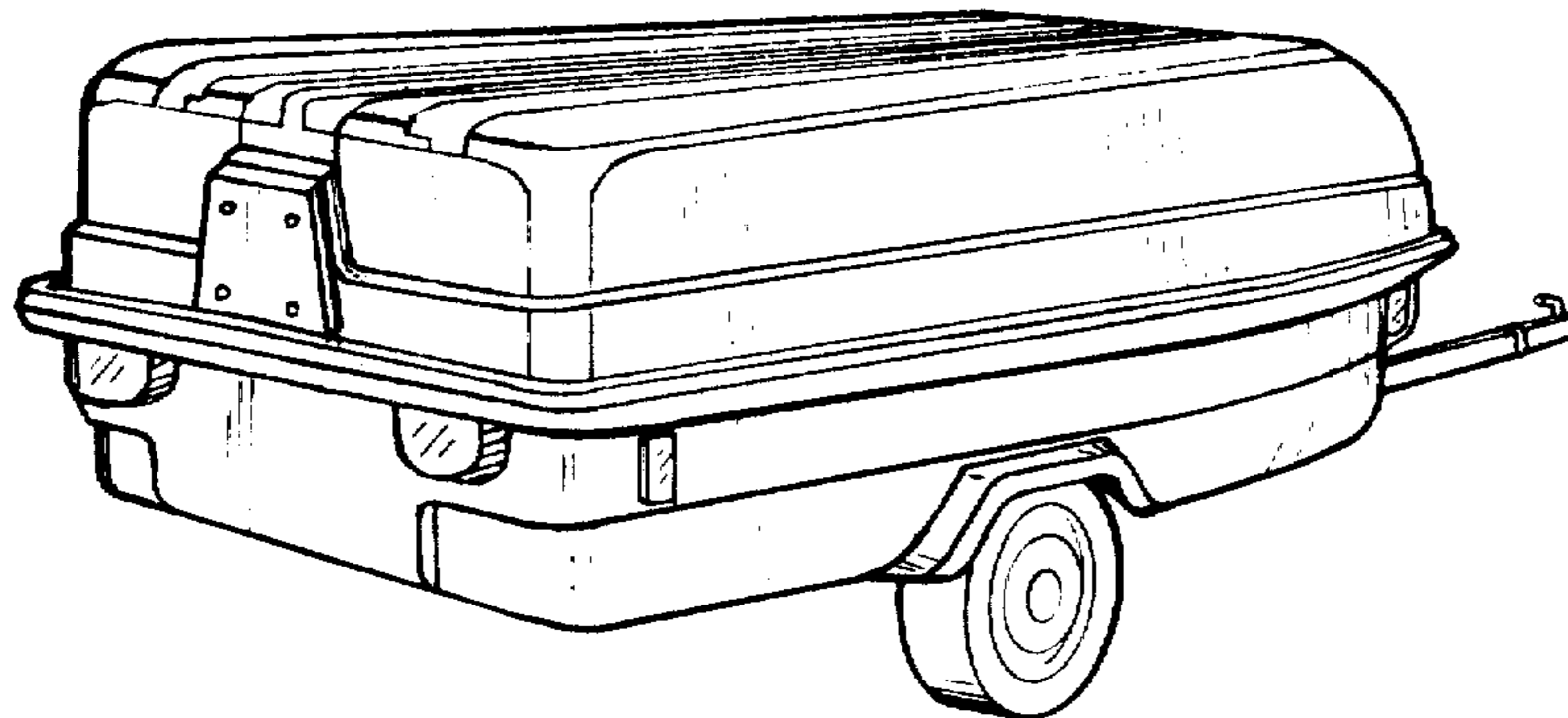

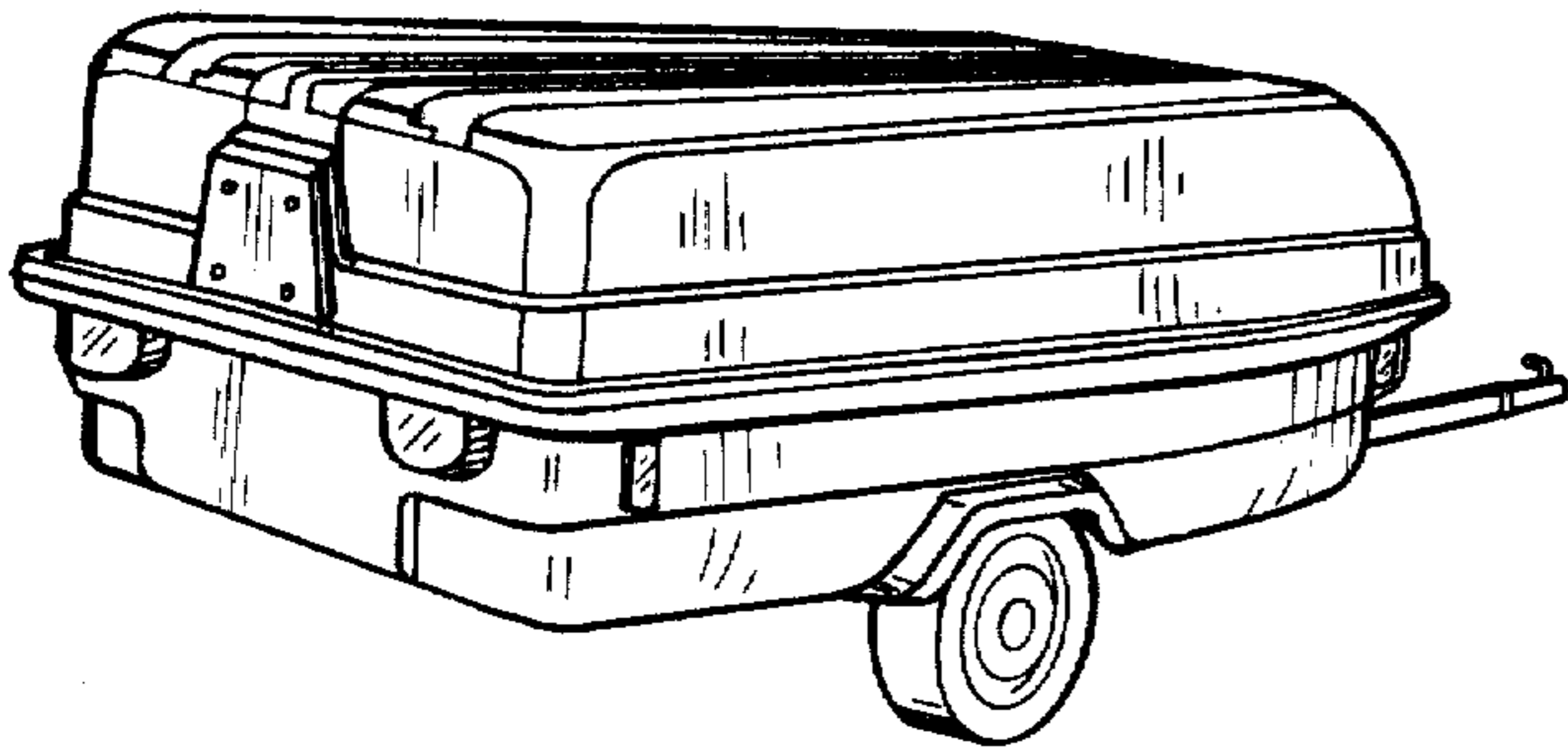

Fig-1

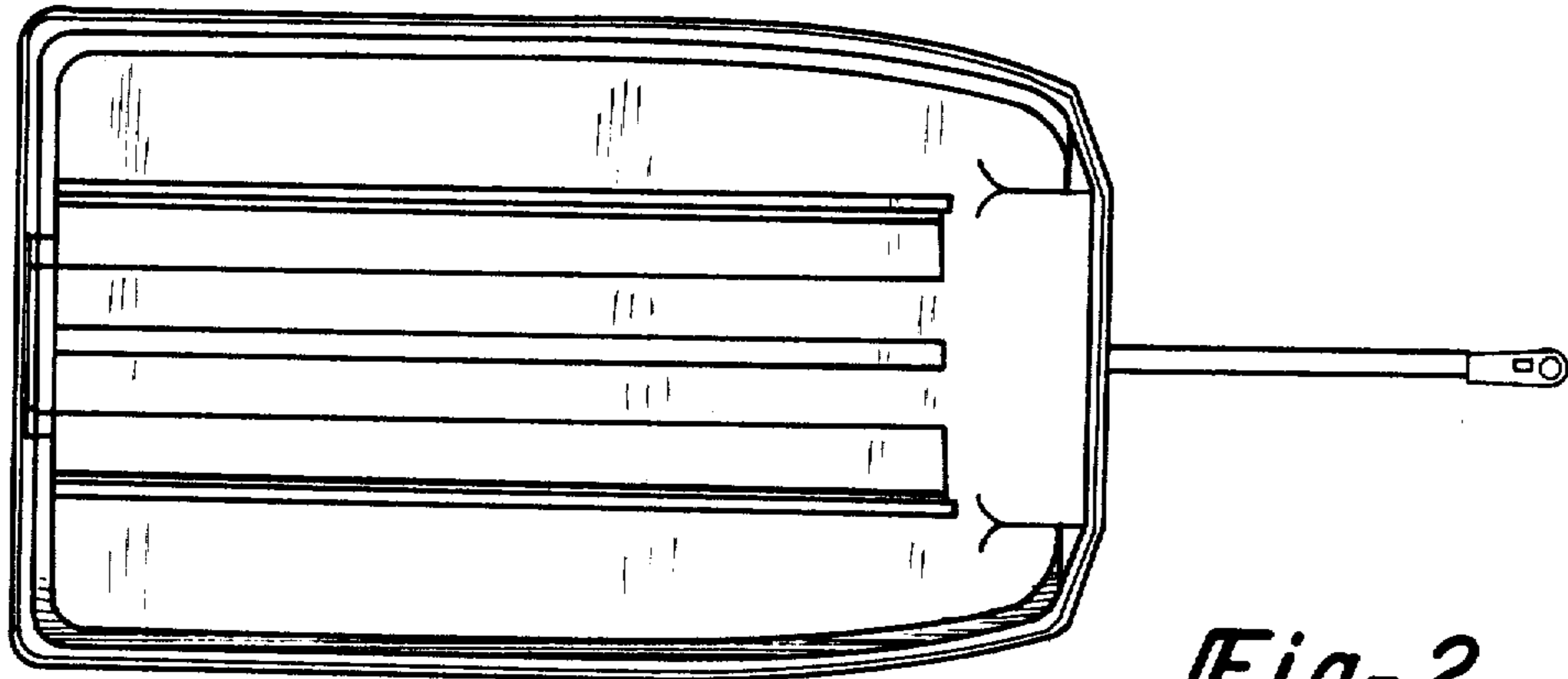

Fig-2

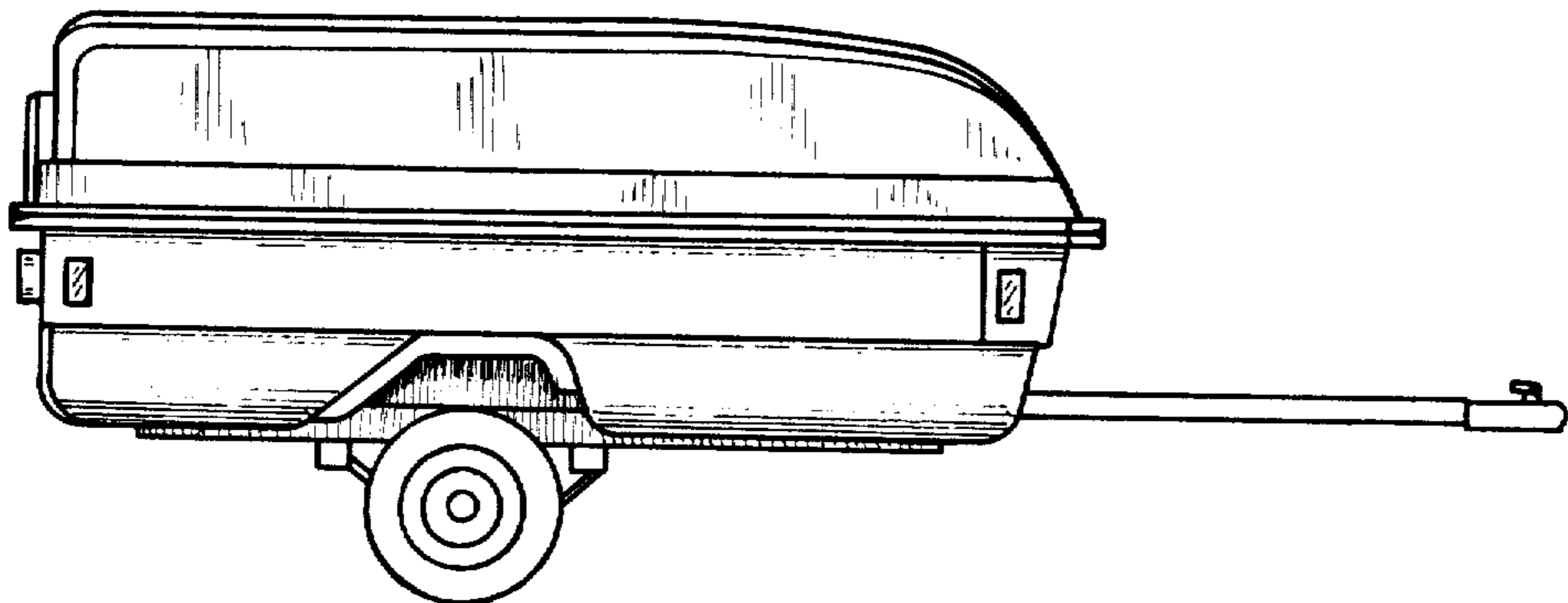

Fig-3

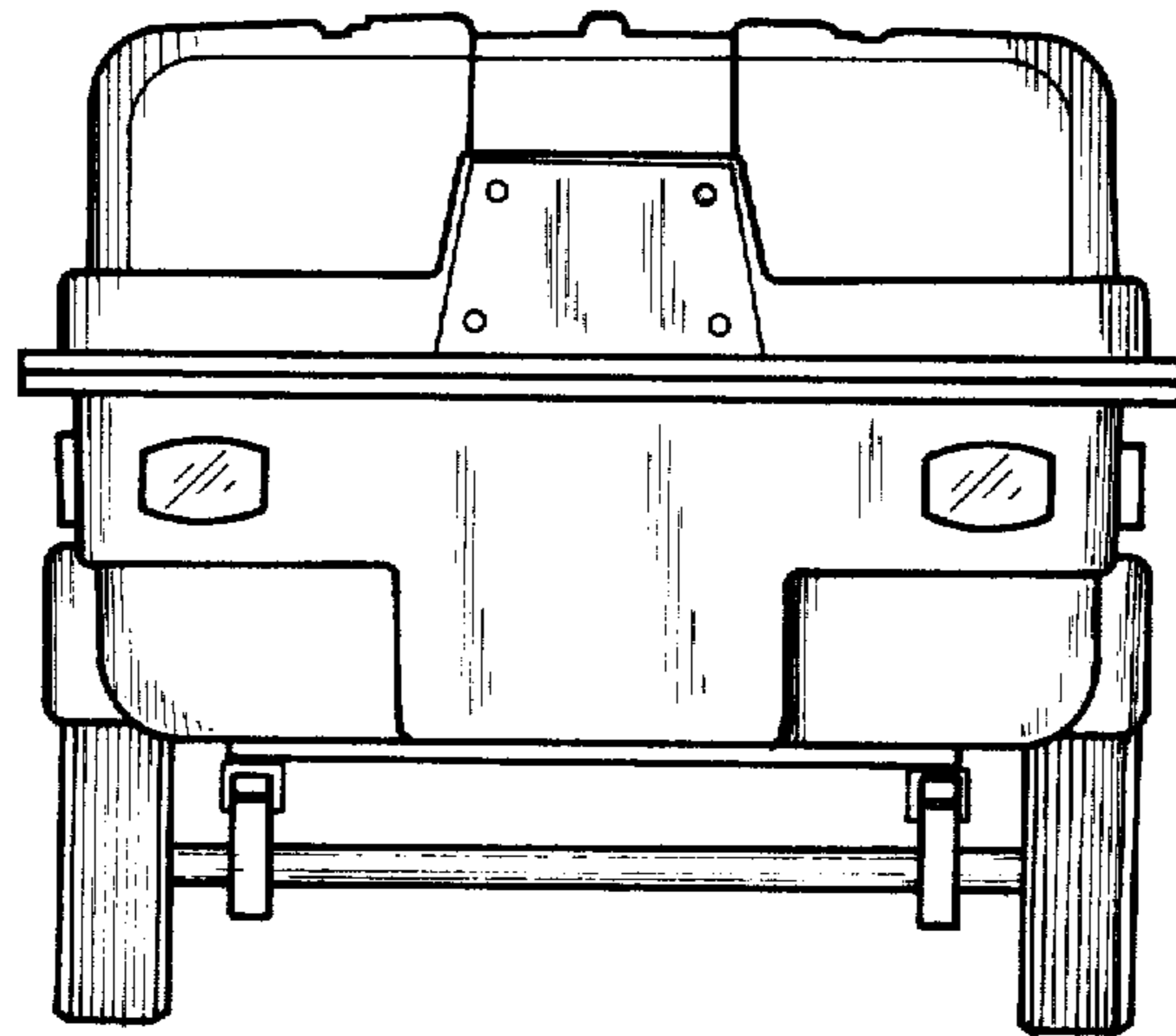

Fig-4

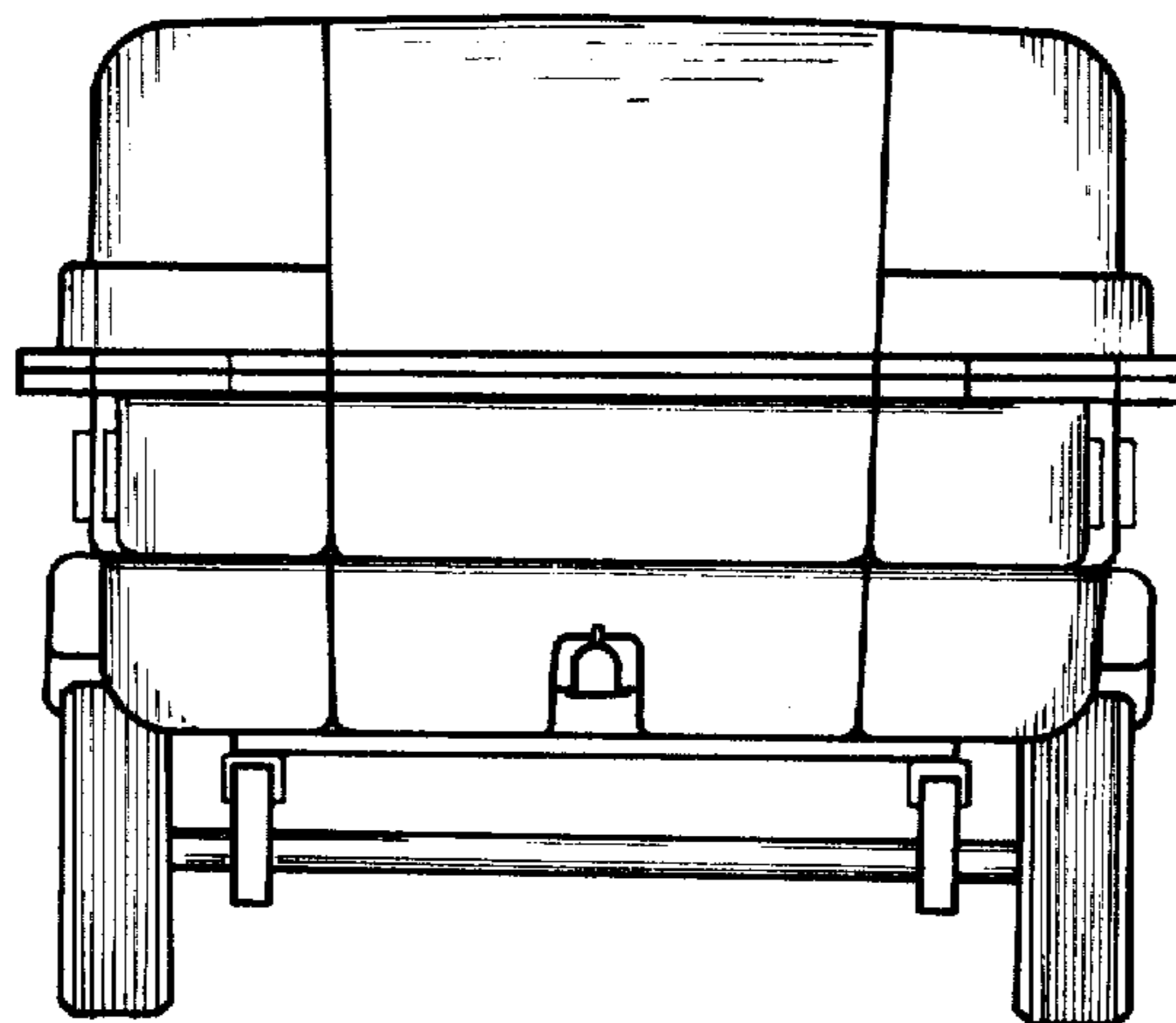

Fig-5

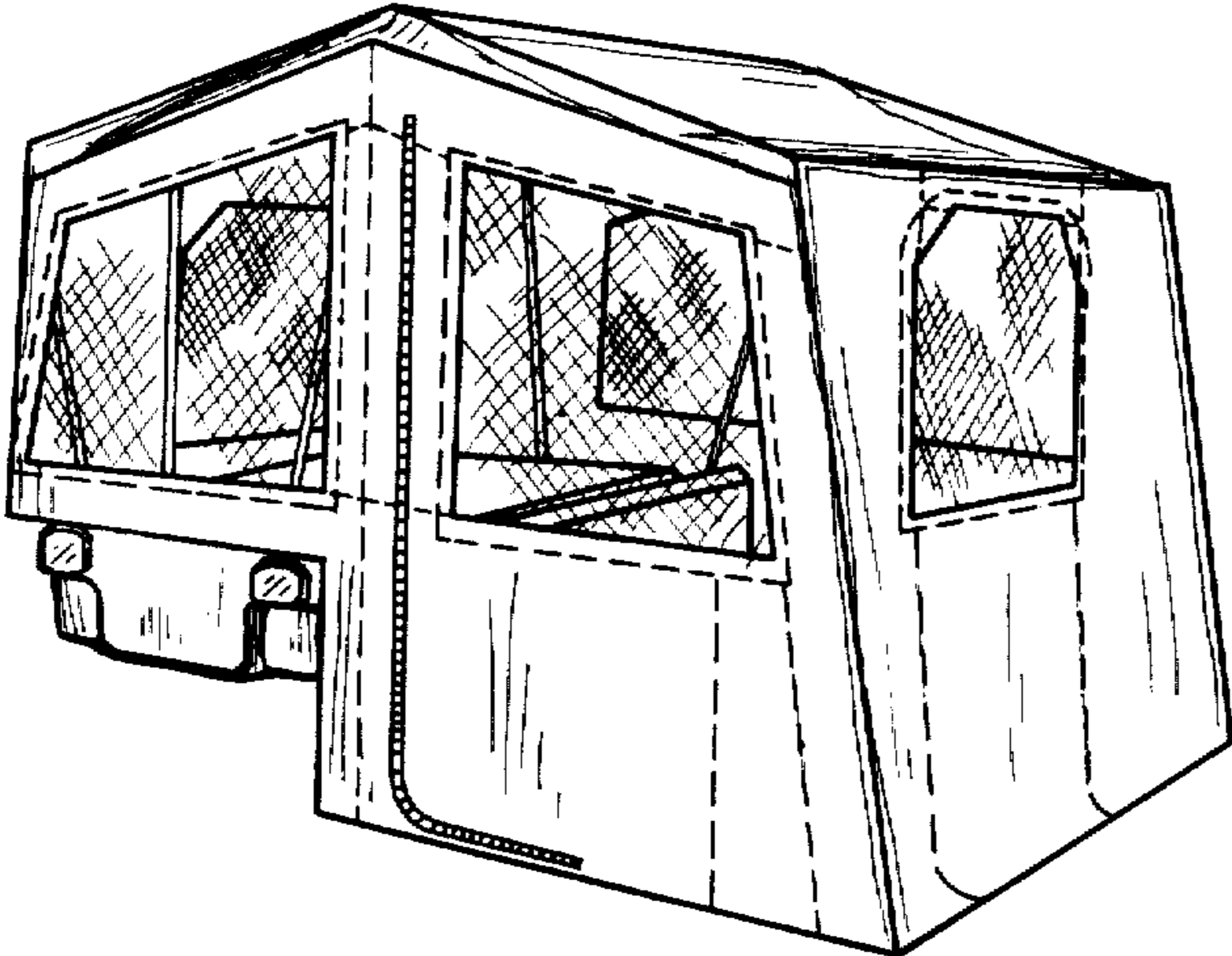

Fig-6

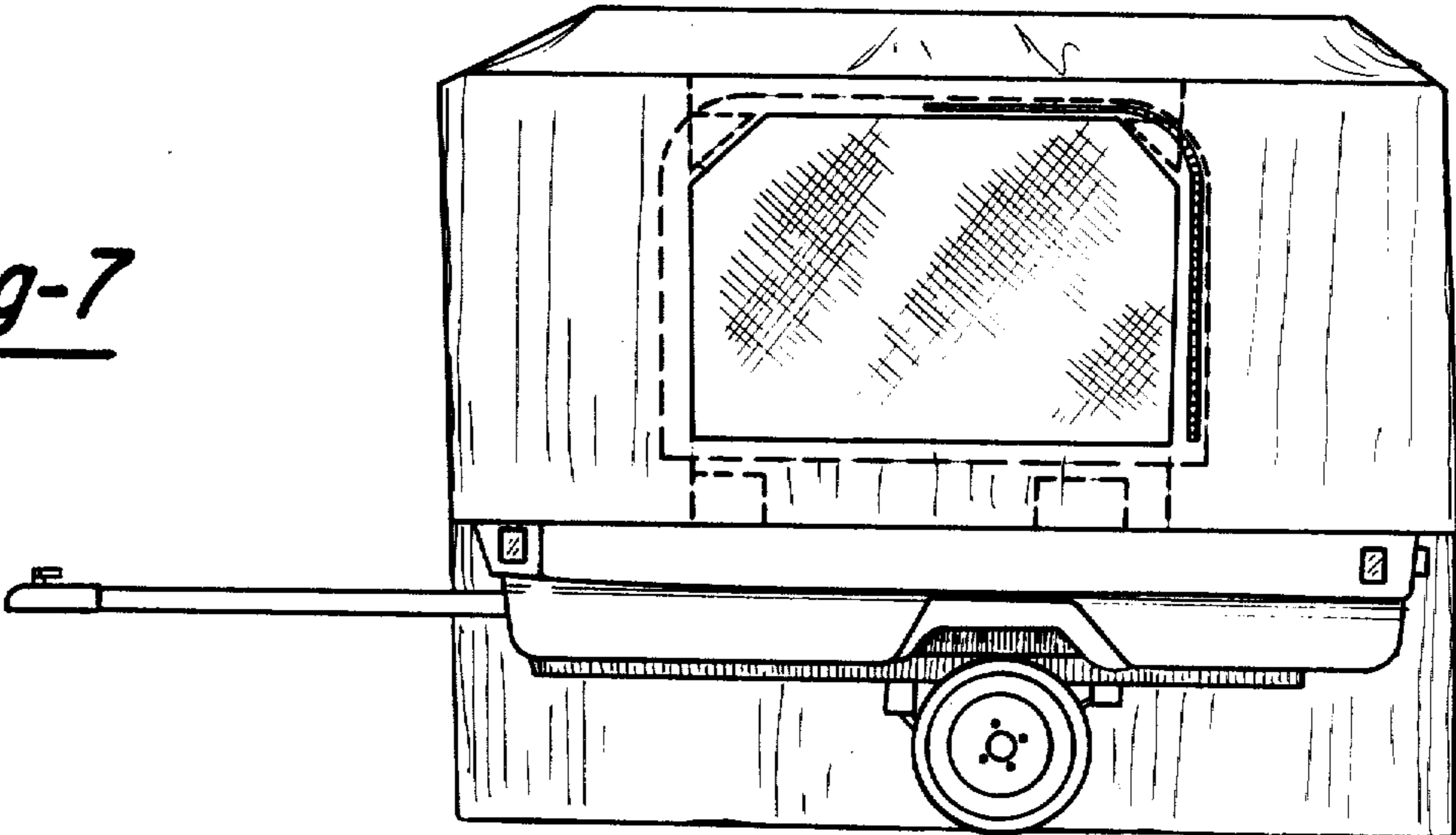

Fig-7

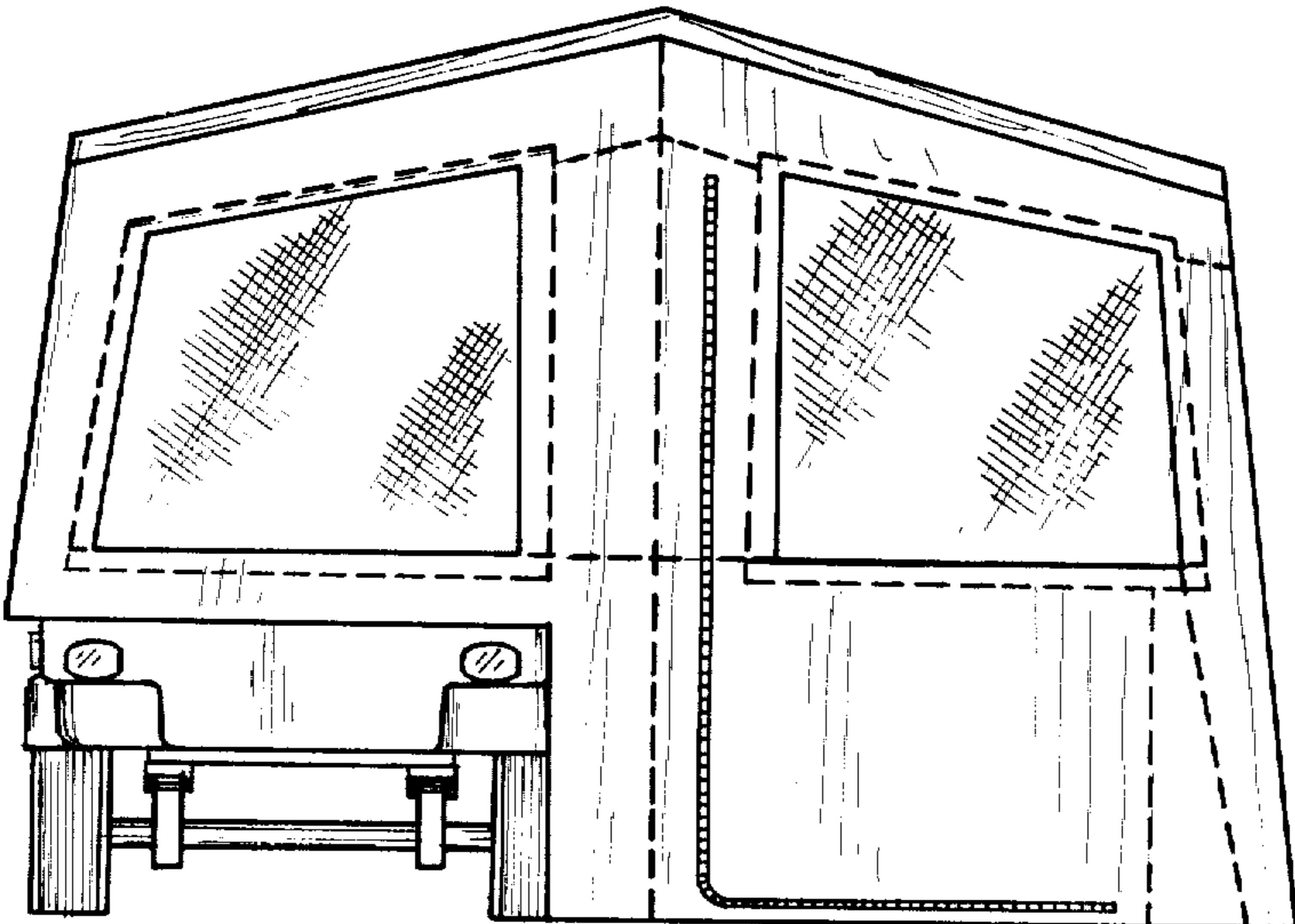

Fig-8

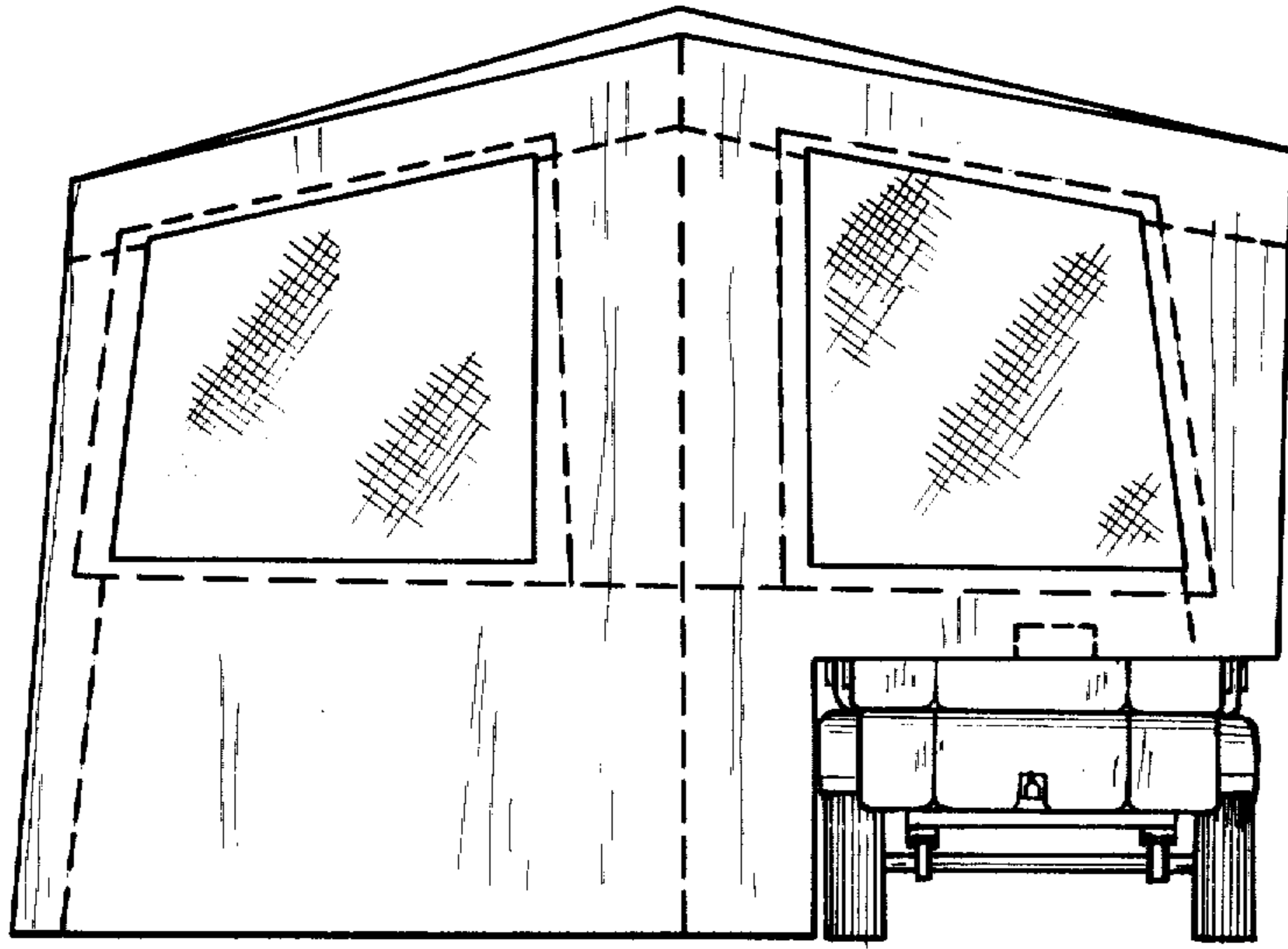

Fig-9

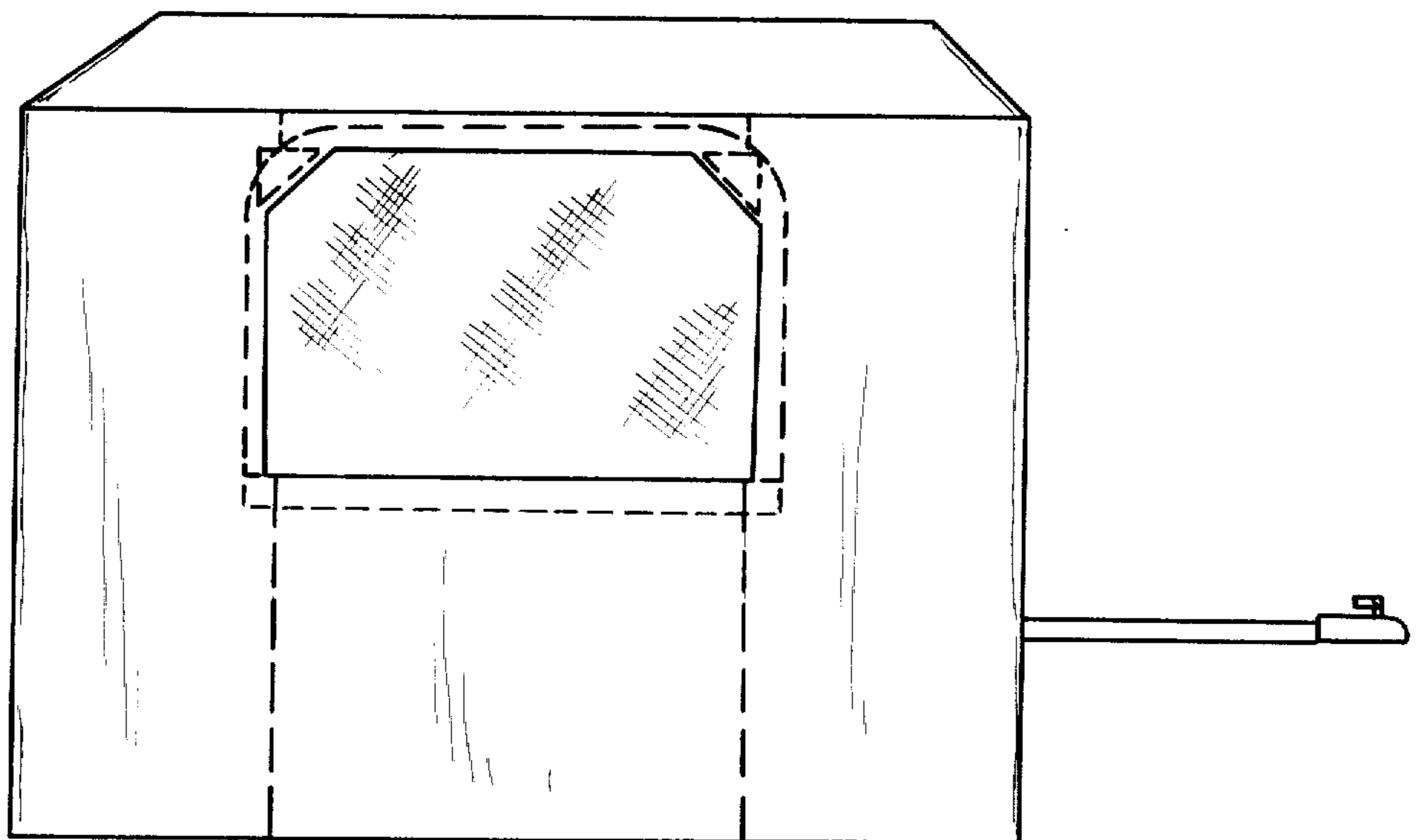

Fig-10

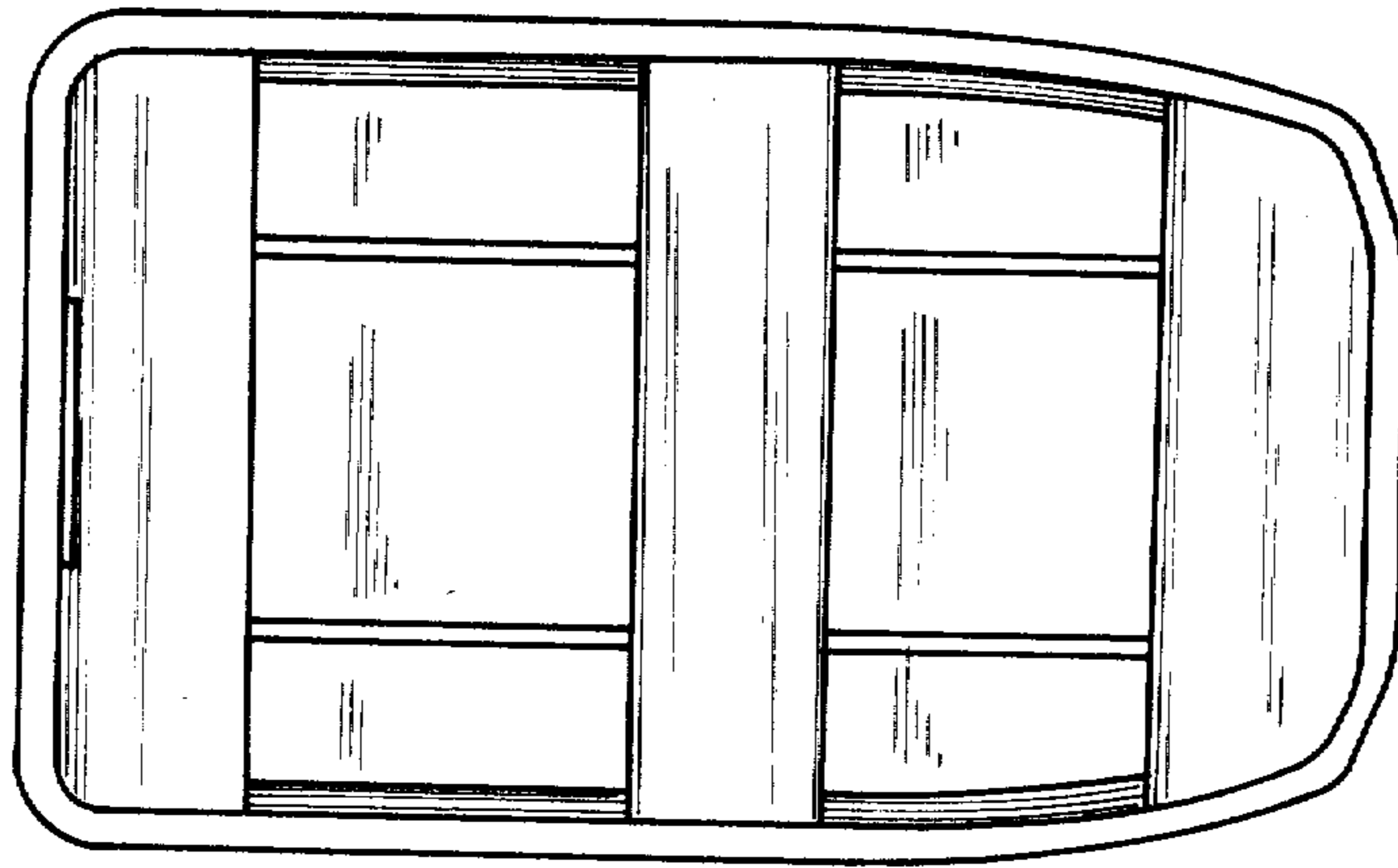

Fig-11

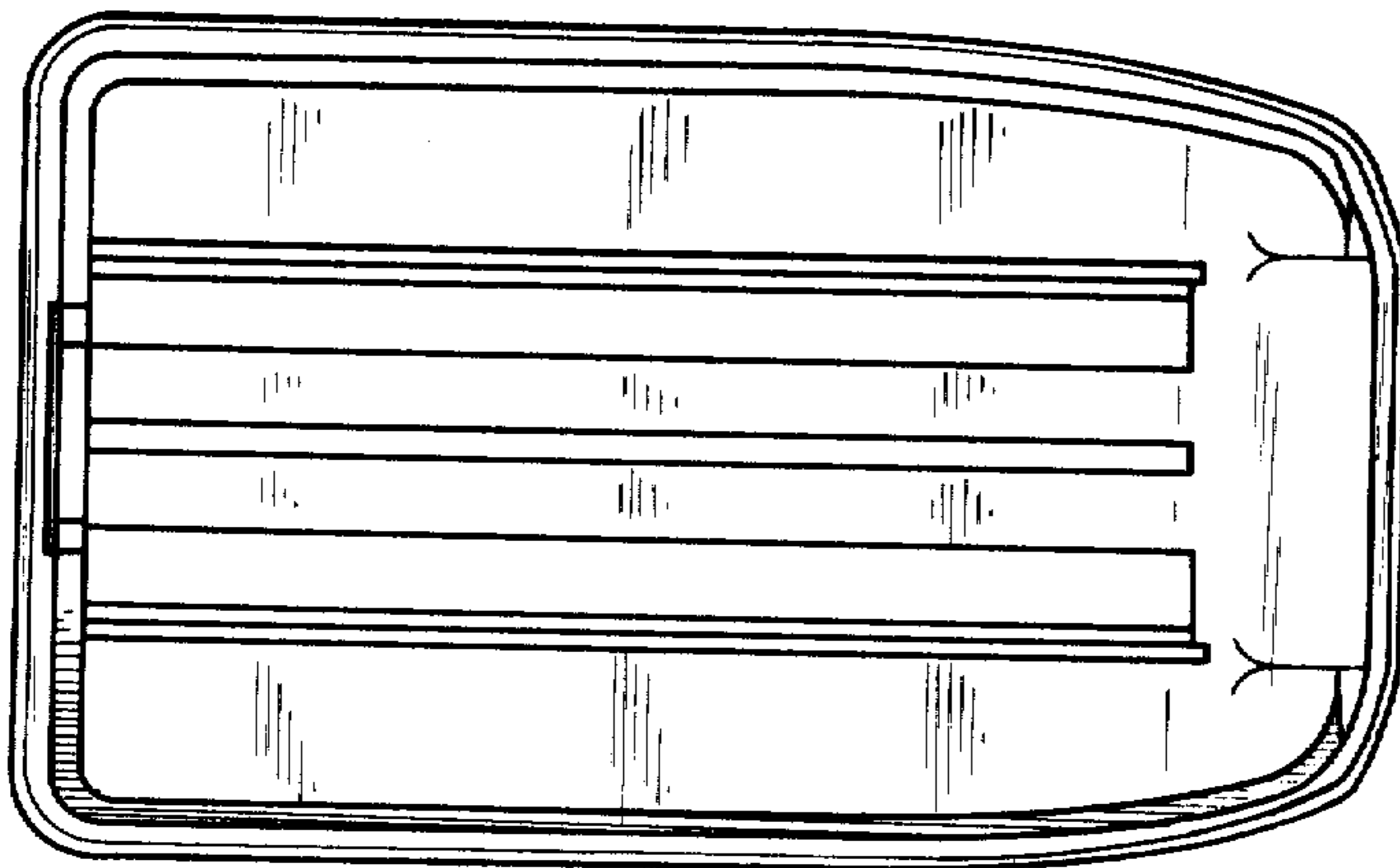

Fig-12

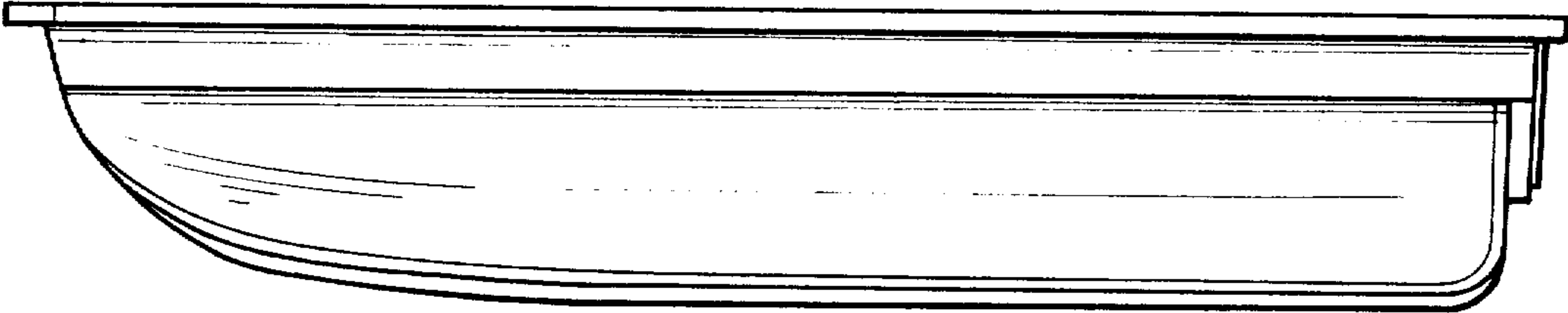

Fig-13

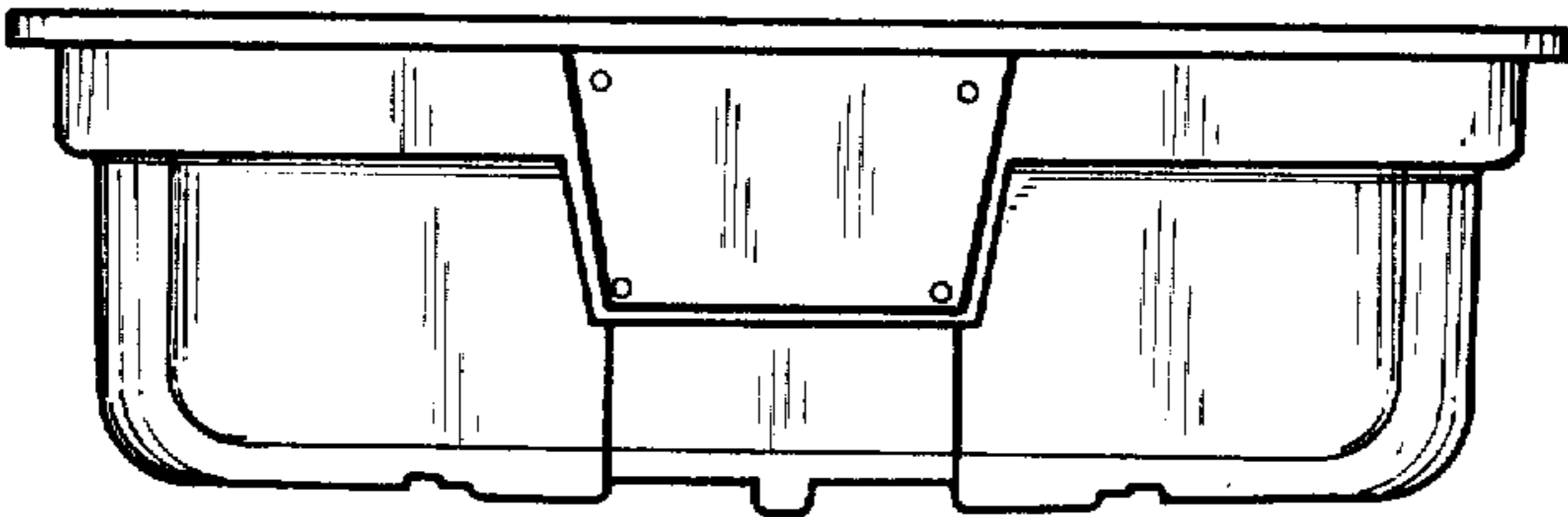

Fig-14

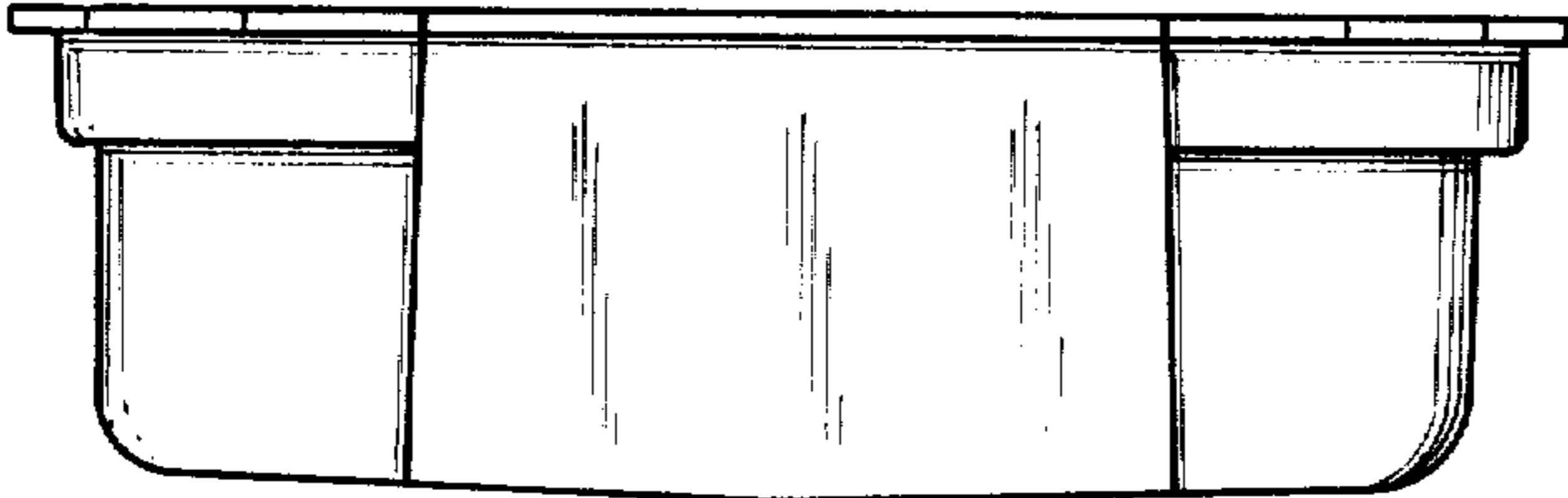

Fig-15

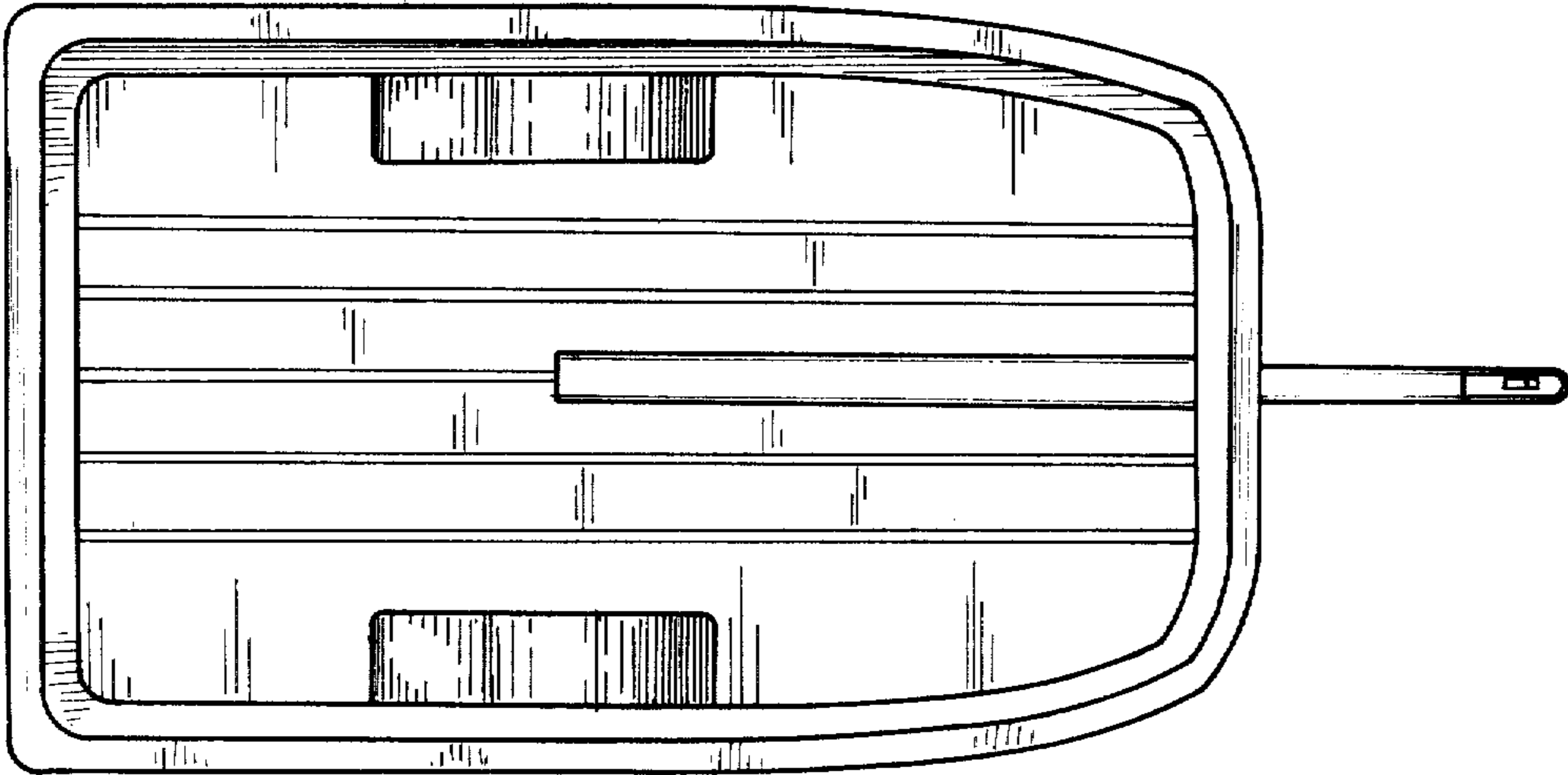

Fig-16

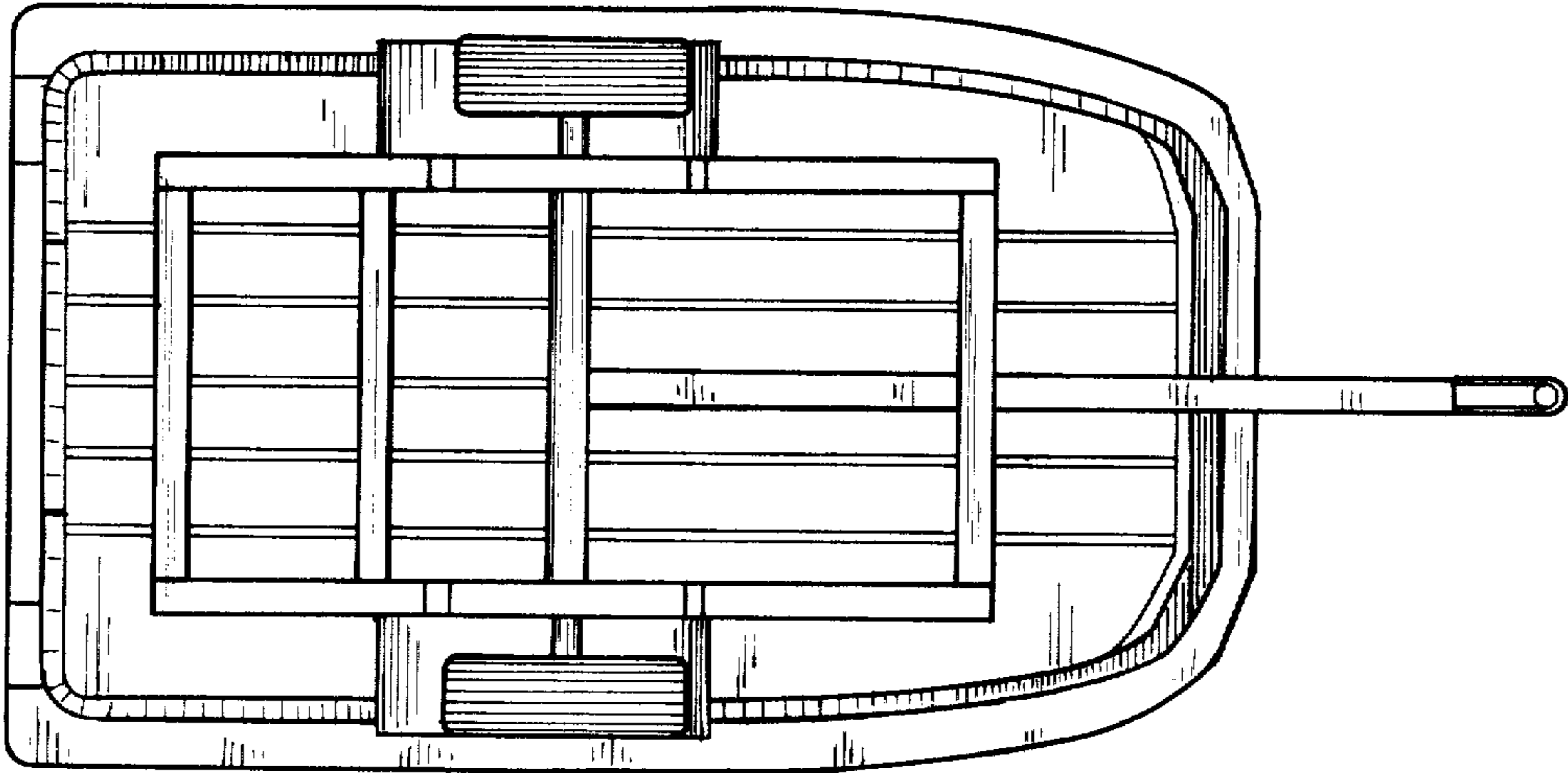

Fig-17

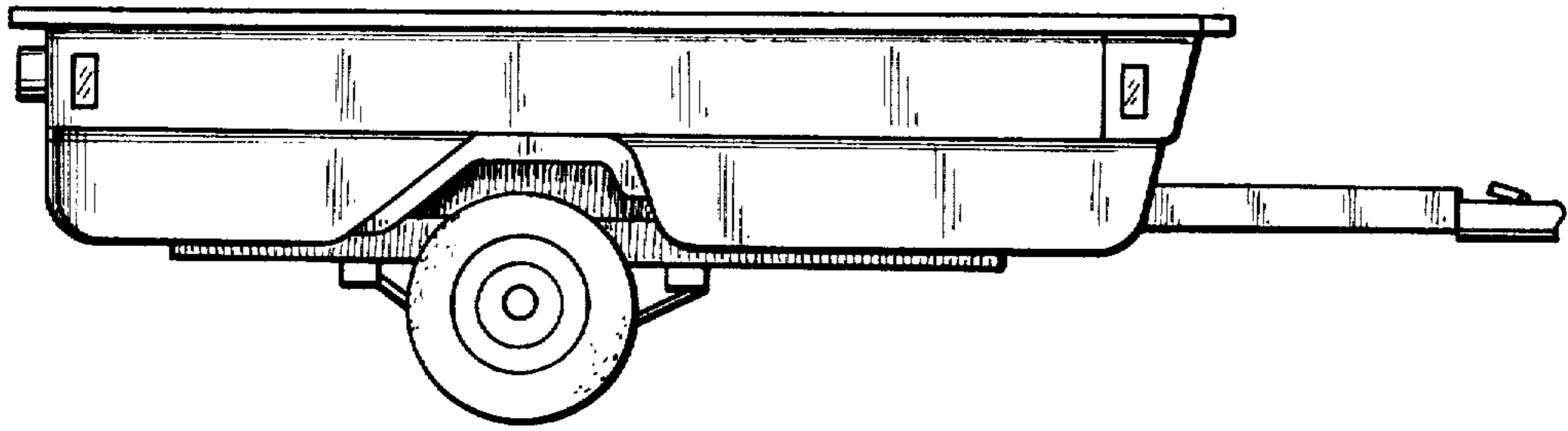

Fig-18

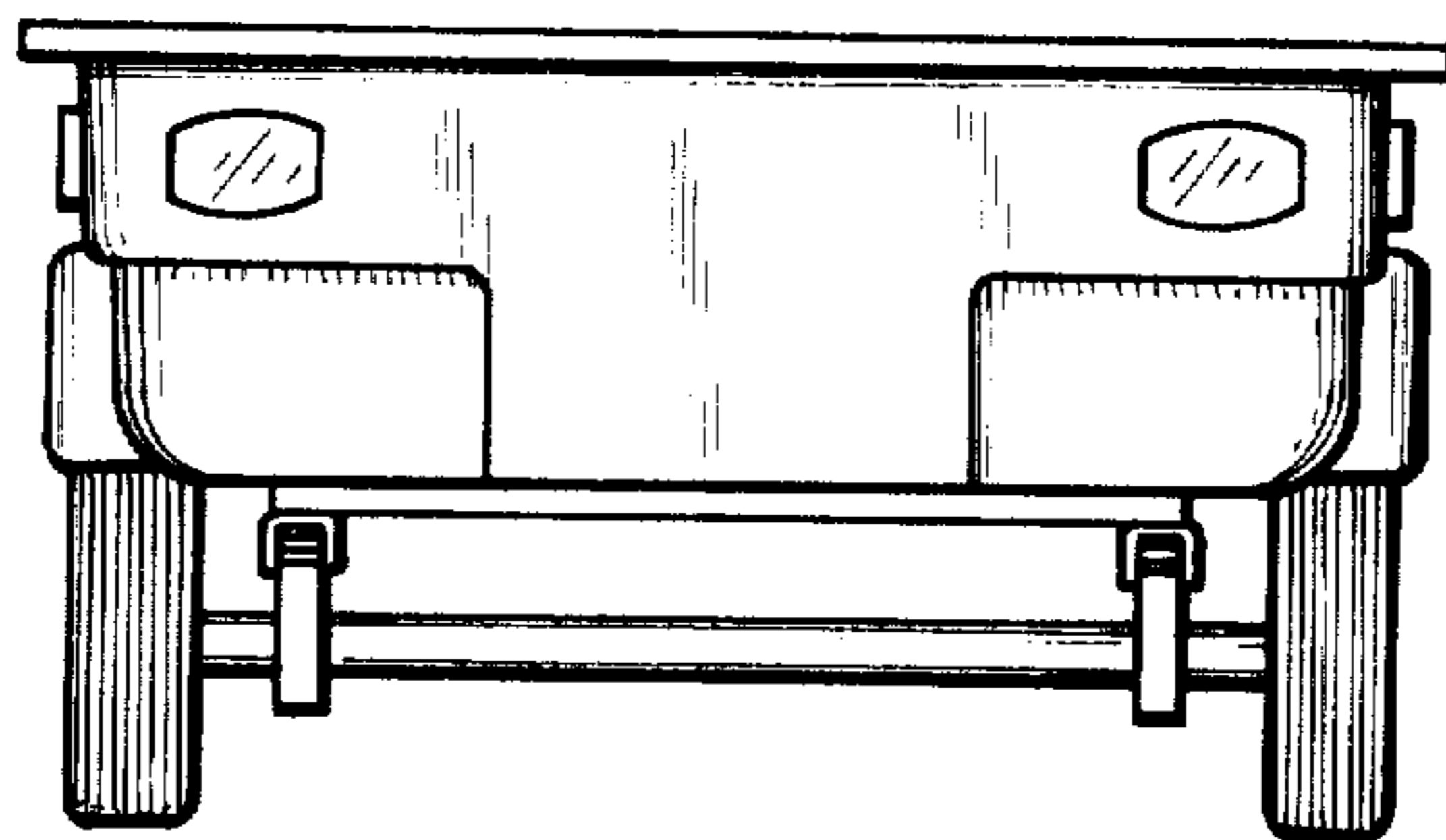

Fig-19

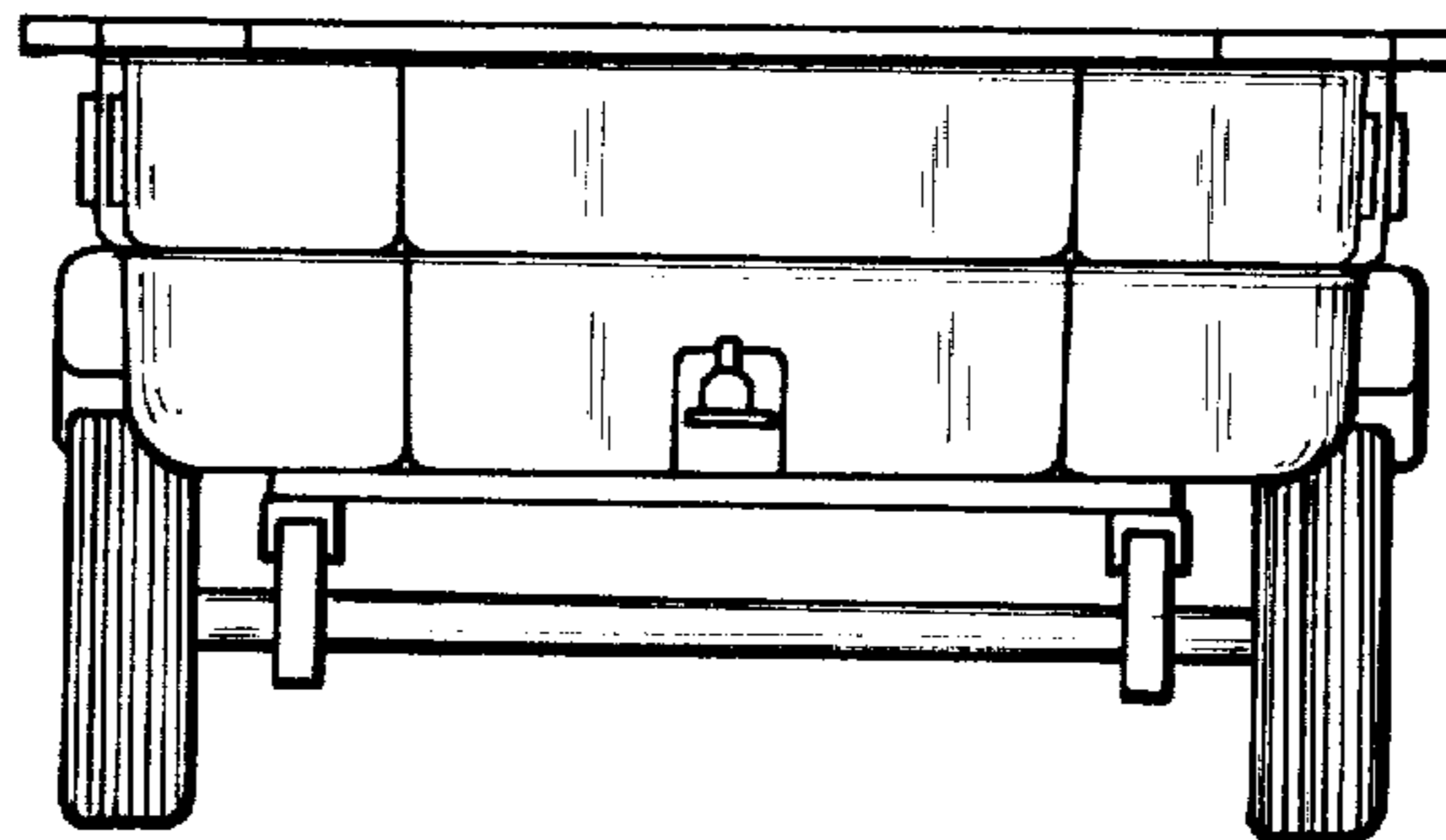

Fig-20