

[54] COMBINED DOOR AND ADVERTISING DISPLAY UNIT FOR A MERCHANDISING COOLER

[75] Inventors: David H. James, Roebuck; Manuel F. Junco, Spartanburg, both of S.C.

[73] Assignee: Tannetics, Inc., Erie, Pa.

[\*\*] Term: 14 Years

[21] Appl. No.: 178,563

[22] Filed: Aug. 15, 1980

[51] Int. Cl. .... D6-04

[52] U.S. Cl. .... D6/187; D20/8; D20/19

[58] Field of Search ..... D6/187; D20/4, 8, 5, D20/10, 19, 42, 43; 40/584, 606; 62/246, 248, 249, 252, 253, 255, 258, 441, 125, 127

[56] References Cited

U.S. PATENT DOCUMENTS

1,374,687	4/1921	Stilwell .....	40/606
2,406,743	9/1946	Crowson .....	40/584
2,888,811	6/1959	Hargrave .....	62/255
3,204,421	9/1965	Jirel .....	62/252 X
4,274,267	6/1981	James et al. ....	D6/187 X

Primary Examiner—Catherine E. Kemper  
Attorney, Agent, or Firm—Dority & Flint

[57] CLAIM

The ornamental design for a combined door and advertising display unit for a merchandising cooler, as shown and described.

DESCRIPTION

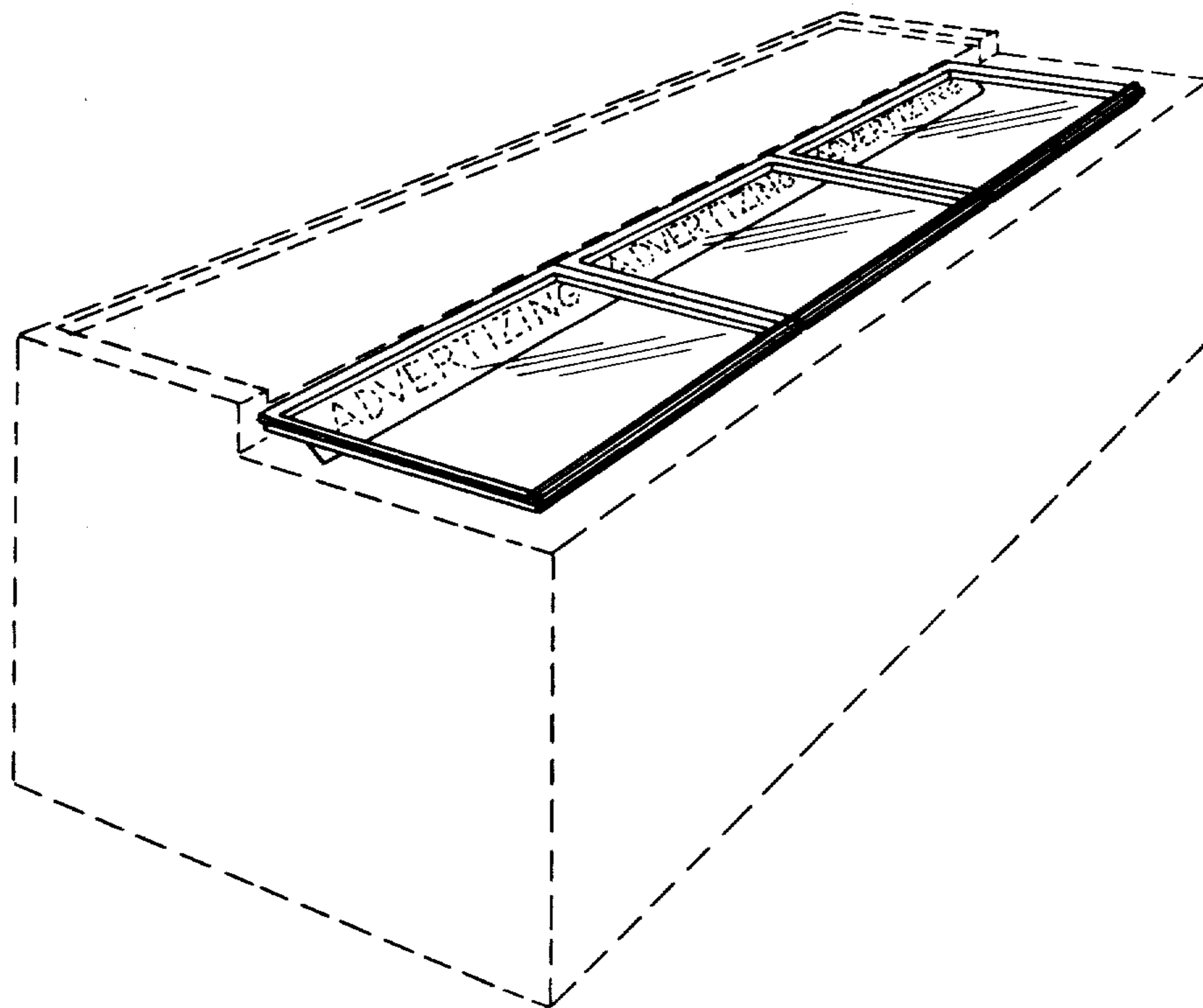
FIG. 1 is a perspective view of a combined door and advertising display unit for a merchandising cooler, showing our new design;

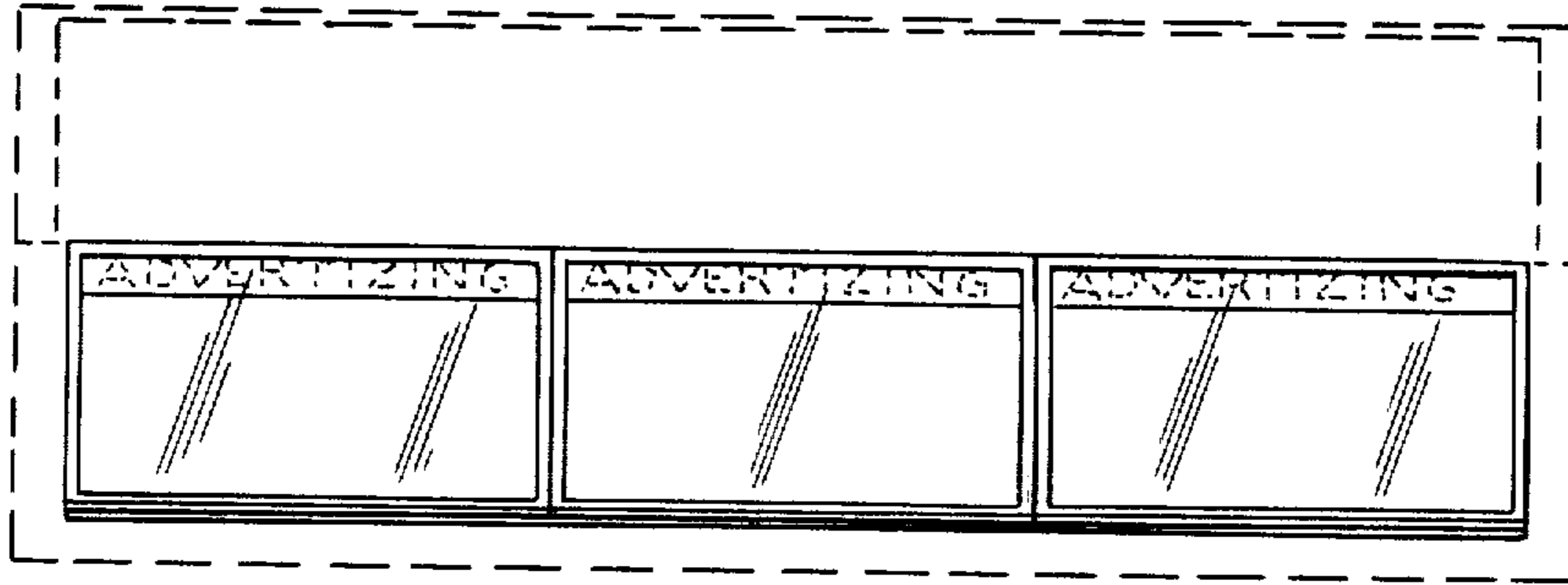
FIG. 2 is a top plan view thereof;

FIG. 3 is an end elevational view thereof;

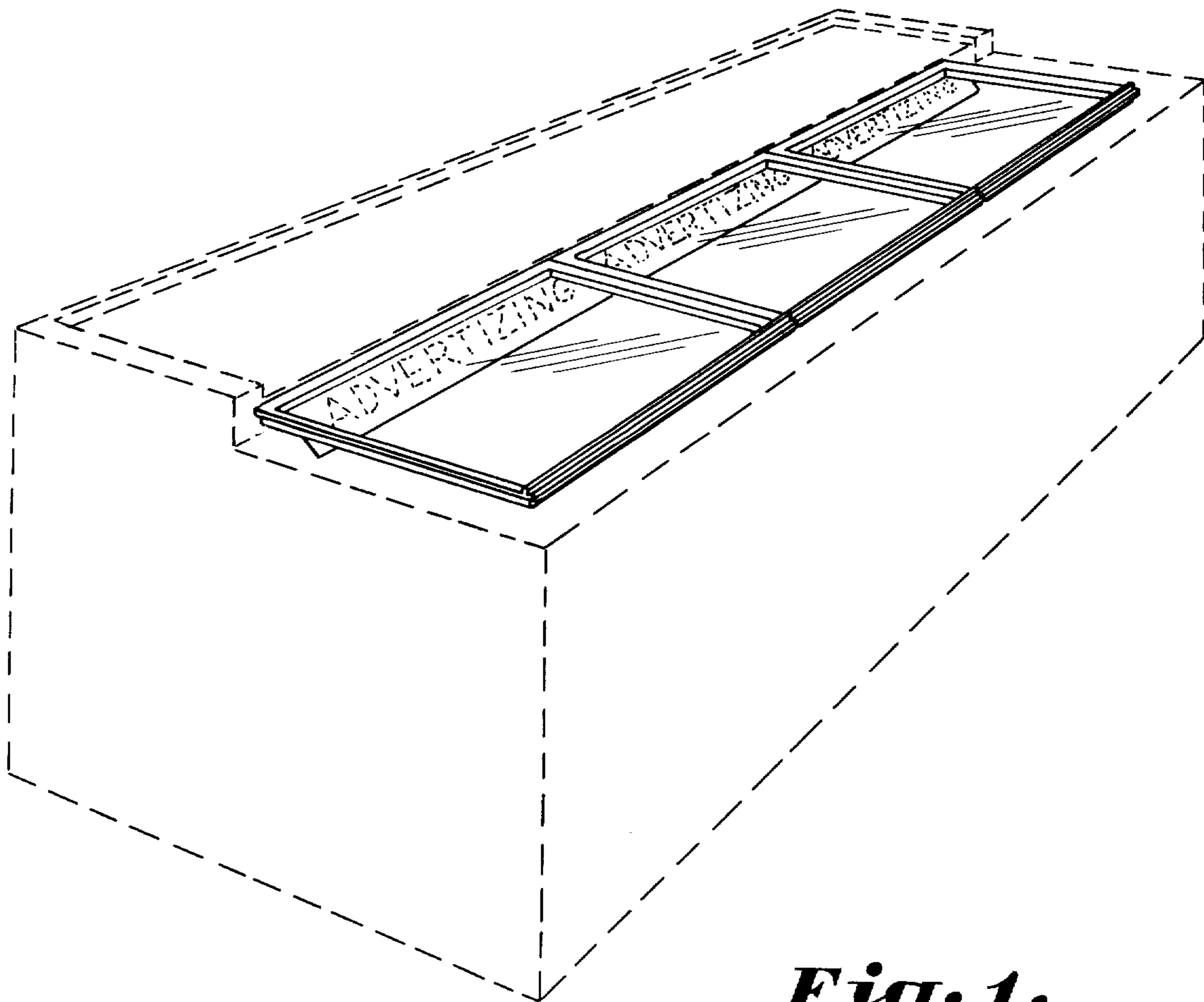
FIG. 4 is a top perspective view thereof.

The broken line disclosure of a merchandising cooler and indicia in all views is for illustrative purposes only and forms no part of the claimed design.



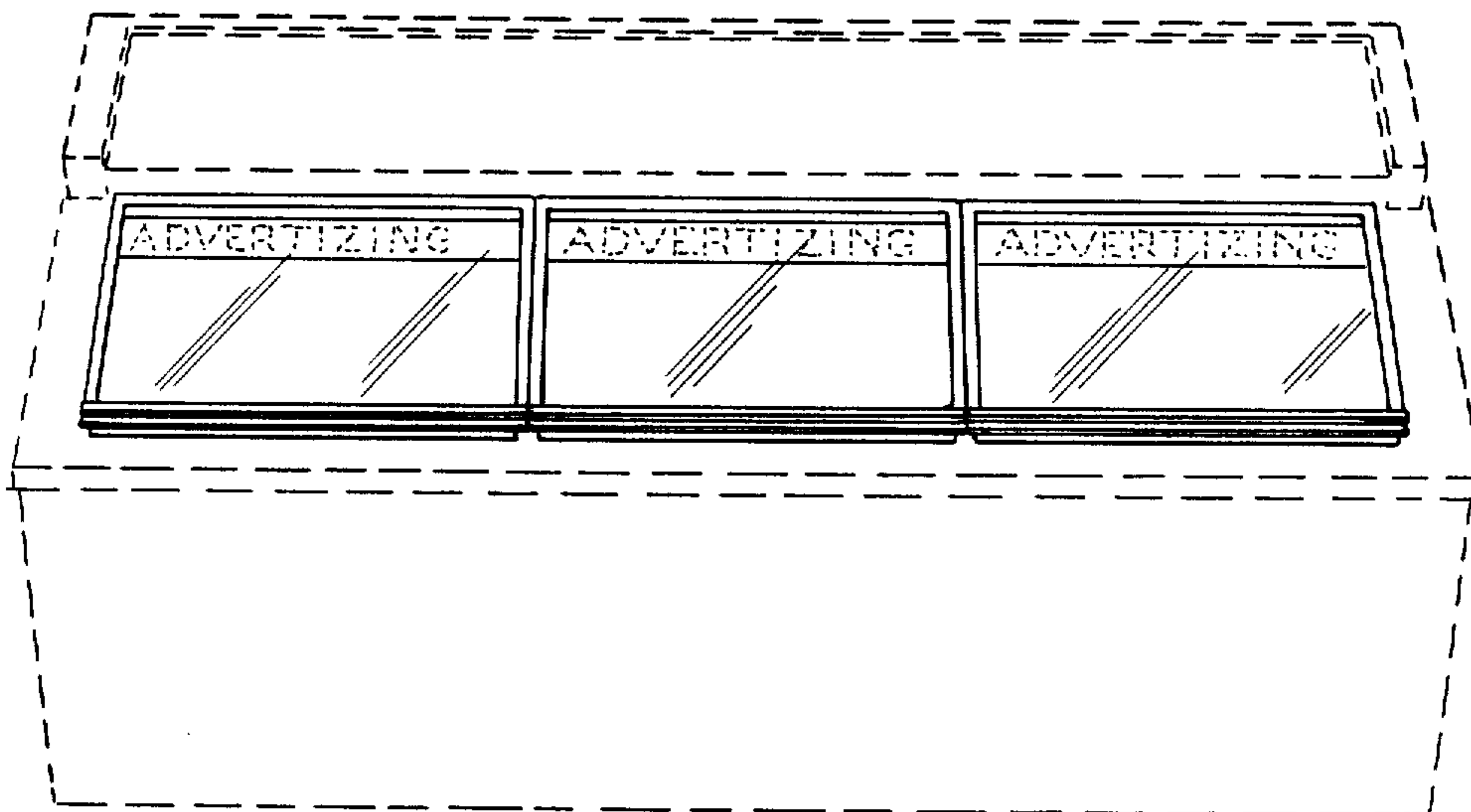
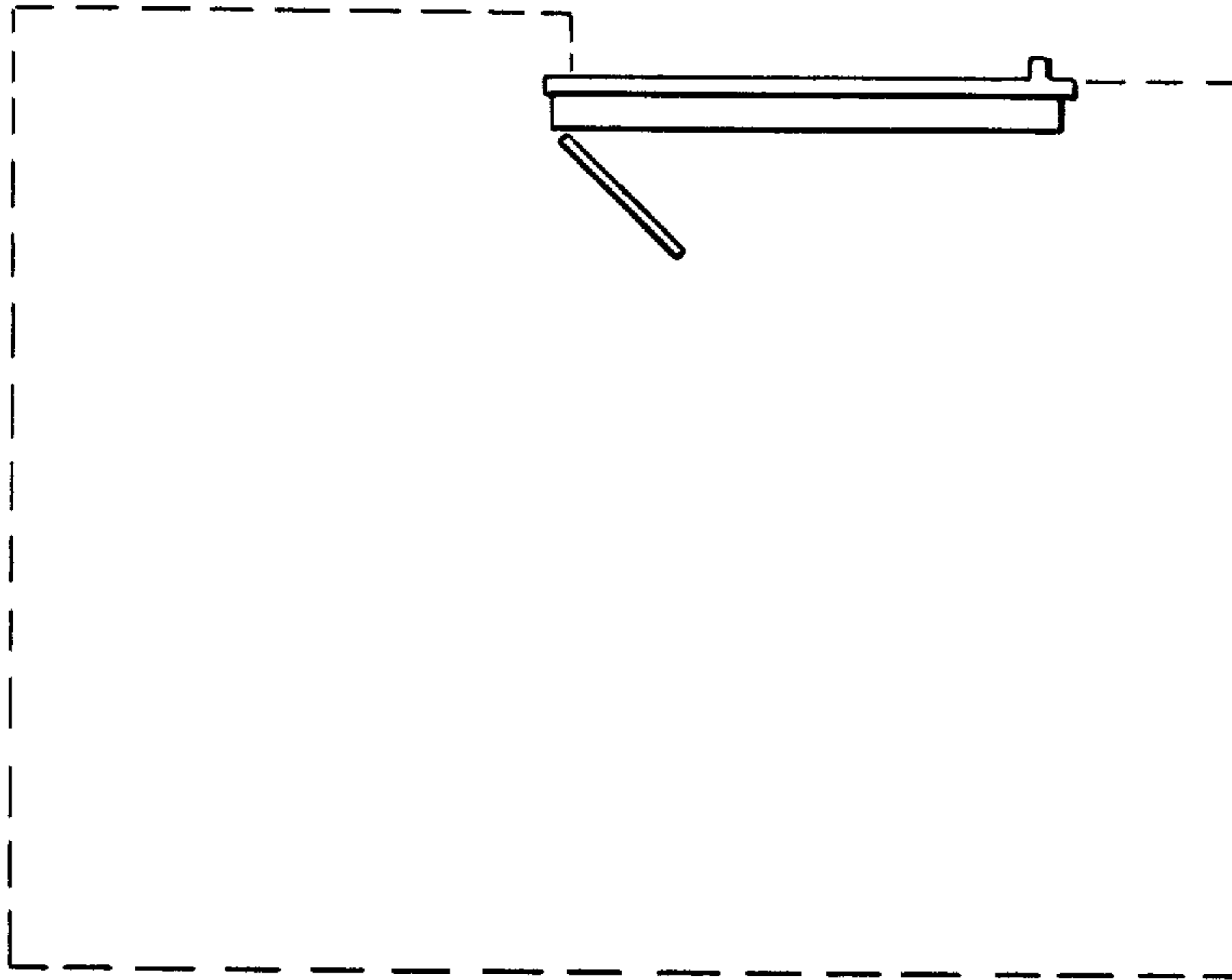


*Fig. 2.*



*Fig. 1.*

*Fig. 3.*



*Fig. 4.*