

[54] **TIRE**

[75] Inventor: **Philippe Grenie**, Clermont-Ferrand, France

[73] Assignee: **Compagnie Generale des Etablissements Michelin**, Clermont-Ferrand, France

[**] Term: **14 Years**

[21] Appl. No.: **218,690**

[22] Filed: **Dec. 22, 1980**

[30] **Foreign Application Priority Data**

Jun. 26, 1980 [FR] France 8033

[51] Int. Cl. **D12-15**

[52] U.S. Cl. **D12/147; D12/144**

[58] Field of Search **D12/141-151; 152/209 R, 209 NT, 209 WT, 209 D**

[56] **References Cited**

PUBLICATIONS

1979 Tread Design Guide, p. 21, Avon Turbosport Tire, bottom center of page.

Modern Tire Dealer, 10/75, p. 23, Michelin TRX Radial Tire, bottom of page.

Primary Examiner—James M. Gandy
Attorney, Agent, or Firm—Brumbaugh, Graves, Donohue & Raymond

[57] **CLAIM**

The ornamental design for a tire, substantially as shown and described.

DESCRIPTION

The FIGURE is a perspective view of a tire showing my new design, it being understood that the tread pattern is repeated throughout the circumference of the tire, as shown schematically by solid lines, the opposite side being substantially the same as that shown.

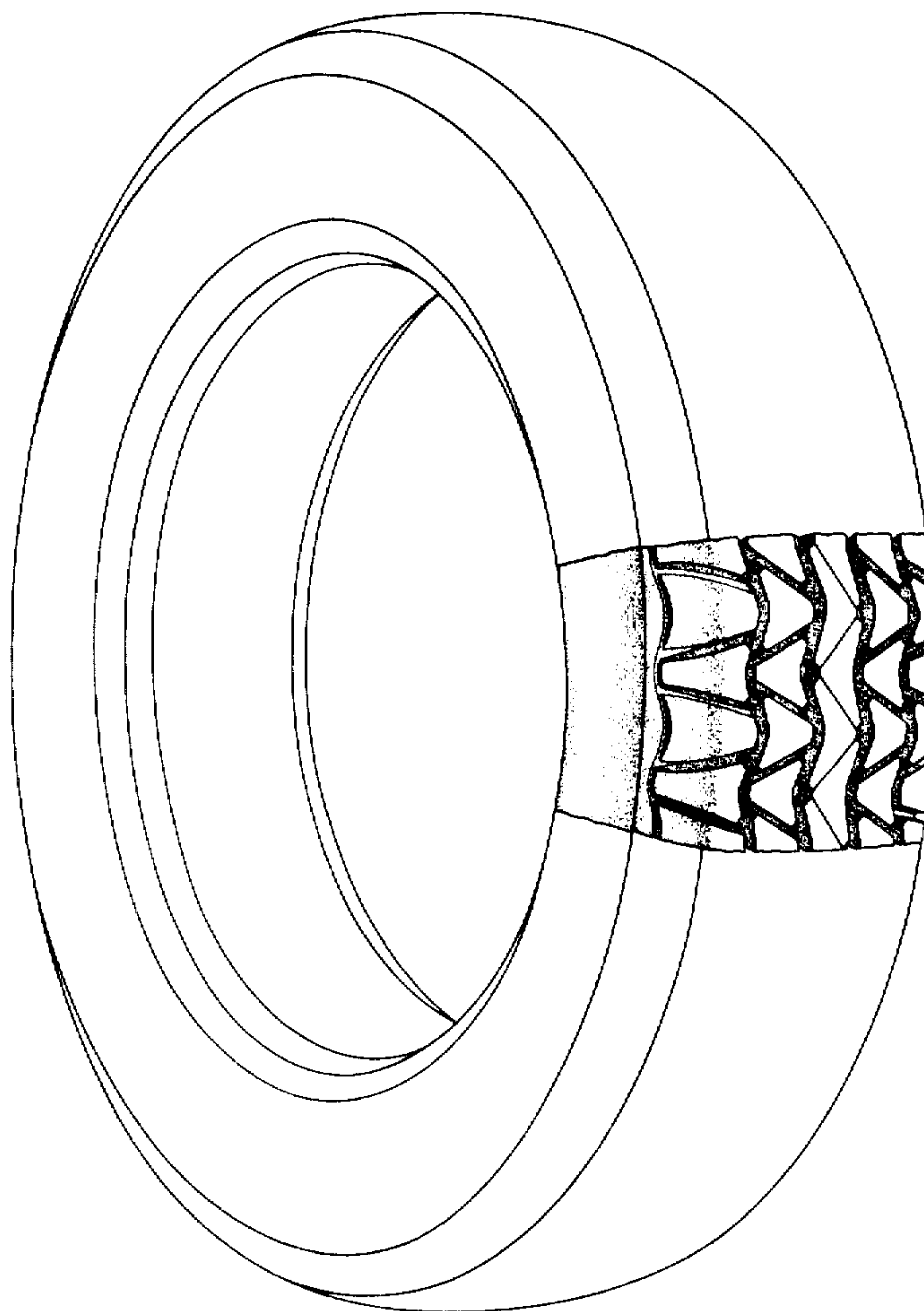

U.S. Patent

Feb. 15, 1983

Des. 267,938

