

- [54] **CAR TELEPHONE SET**
- [75] **Inventors:** Hisao Fukushima; Junji Hirooka,
both of Tokyo, Japan
- [73] **Assignee:** Oki Electric Industry Co., Ltd.,
Tokyo, Japan
- [**] **Term:** 14 Years
- [21] **Appl. No.:** 168,001
- [22] **Filed:** Jul. 14, 1980
- [30] **Foreign Application Priority Data**
Jan. 21, 1980 [JP] Japan 55-1065
- [51] **Int. Cl.** D14-03
- [52] **U.S. Cl.** D14/53
- [58] **Field of Search** D14/53, 52, 58, 56;
179/178, 179, 100 D, 100 R, 100 L
- [56] **References Cited**
U.S. PATENT DOCUMENTS
- | | | | | |
|------------|--------|------------------|-------|--------|
| D. 256,234 | 8/1980 | Fukushima et al. | | D14/53 |
| D. 257,841 | 1/1981 | Tada | | D14/53 |
| D. 259,419 | 6/1981 | Carter | | D14/53 |
| D. 260,518 | 9/1981 | Larson | | D14/53 |

3,444,329 5/1960 Krumreich 179/100 R

Primary Examiner—Bernard Ansher
Attorney, Agent, or Firm—Berger & Palmer

[57] **CLAIM**

The ornamental design for a car telephone set, as shown and described.

DESCRIPTION

FIG. 1 is a front elevation of a car telephone set showing our new design;
FIG. 2 is a rear elevation thereof;
FIG. 3 is a left side elevation thereof;
FIG. 4 is a right side elevation thereof;
FIG. 5 is a top plan view thereof;
FIG. 6 is a bottom plan view thereof;
FIG. 7 is a side perspective view thereof;
FIG. 8 is a side perspective view with the handset removed from the telephone base; and
FIG. 9 is a perspective view taken in an alternate position from FIG. 7;
FIG. 10 is a top perspective view of the telephone set mounted on a vehicle dash.
The broken lines are shown for illustrative purposes only.

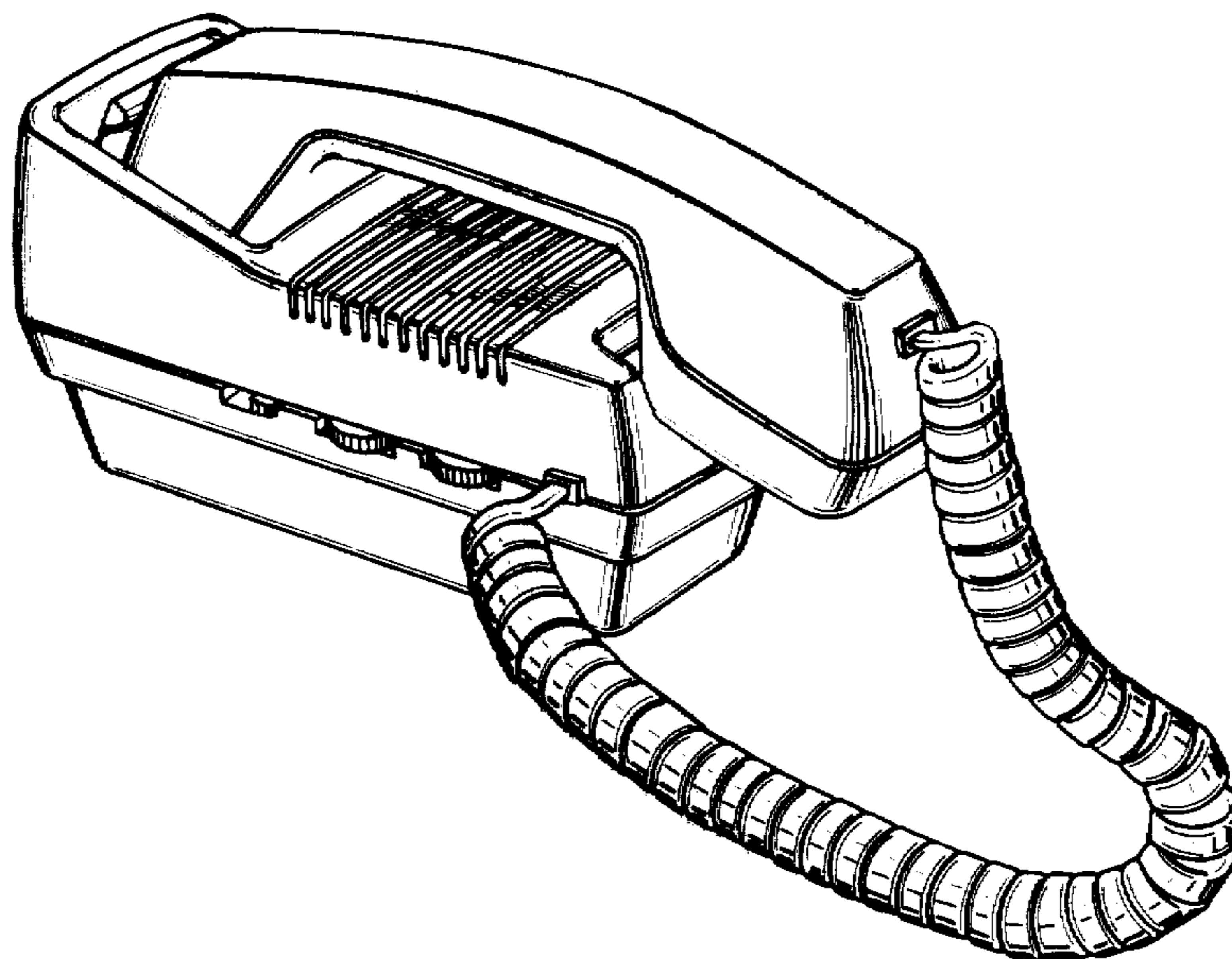

FIG. 1

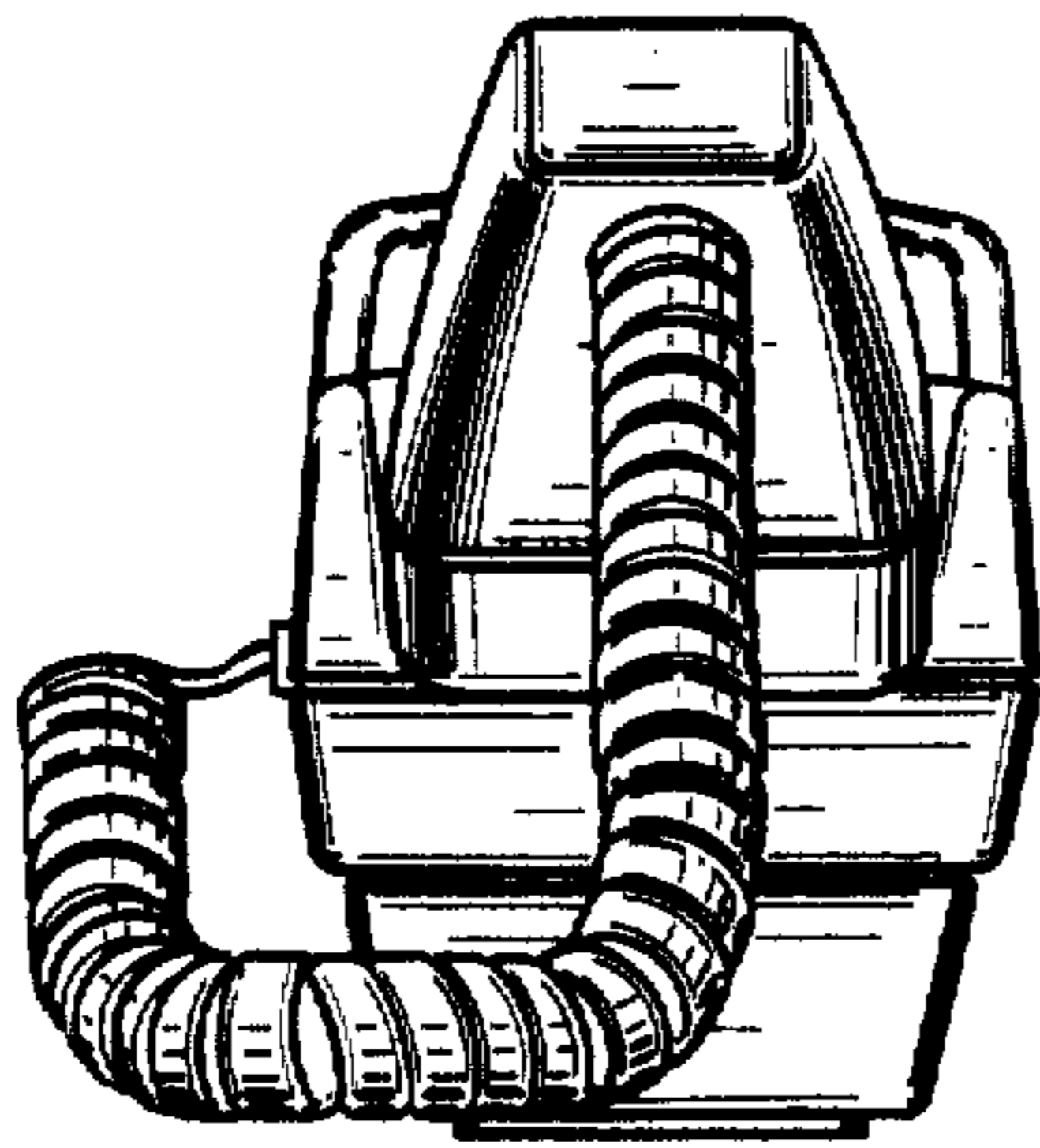

FIG. 2

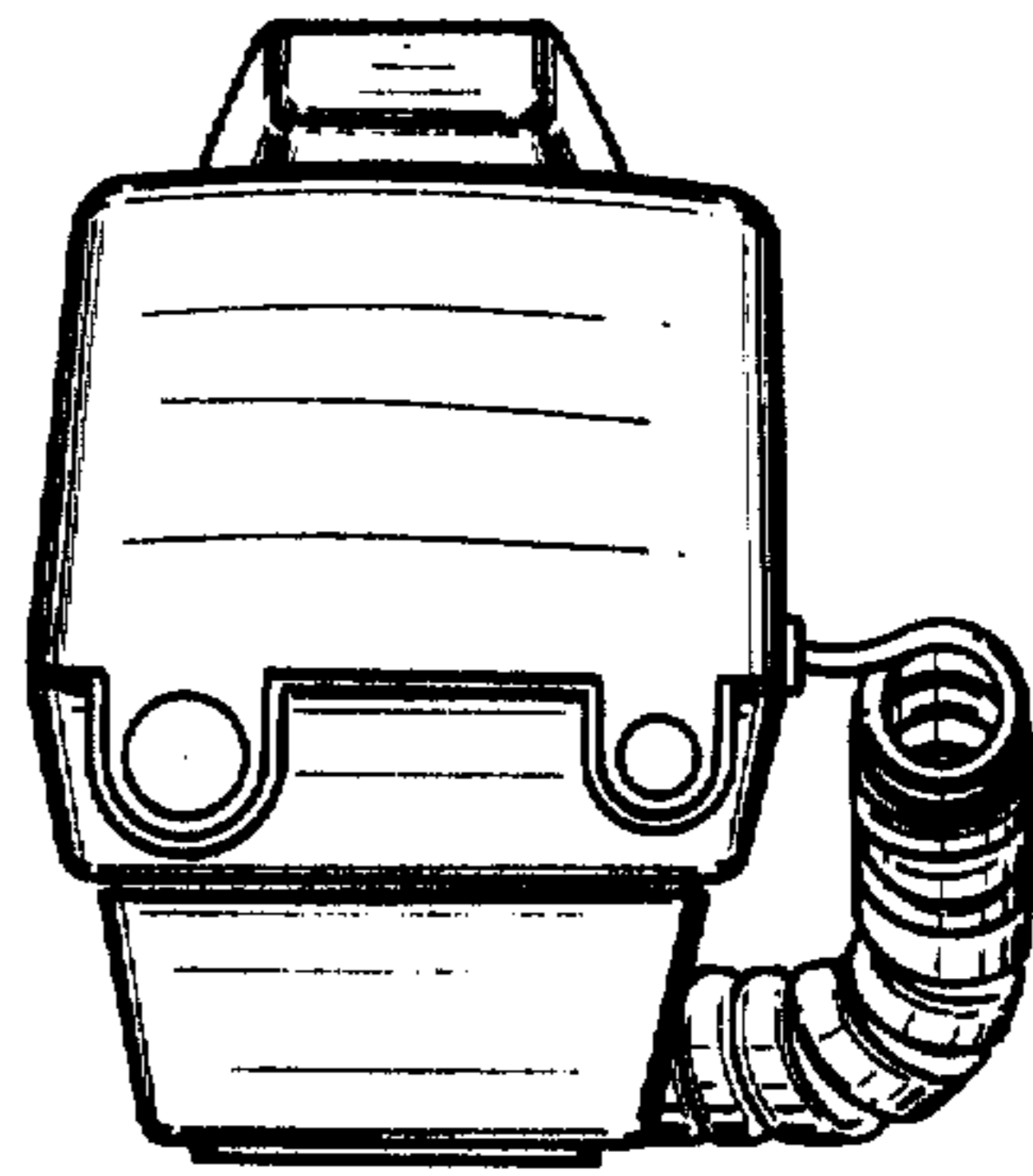

FIG. 3

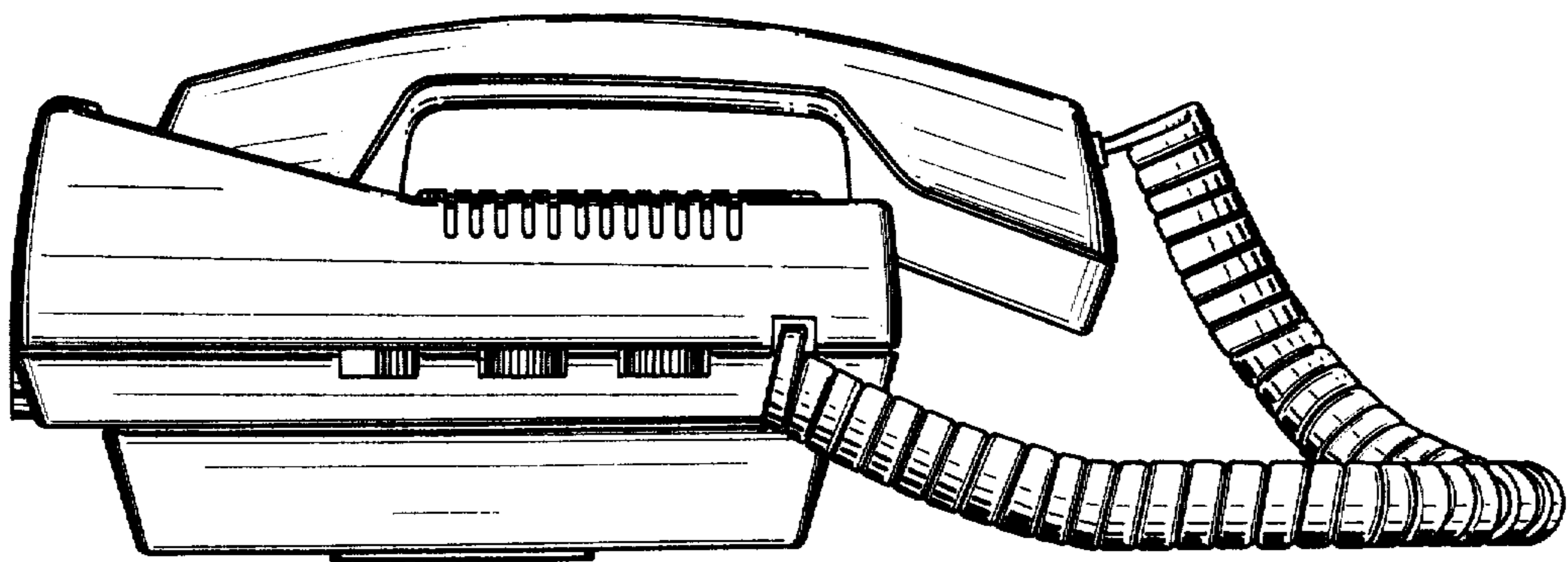

FIG. 4

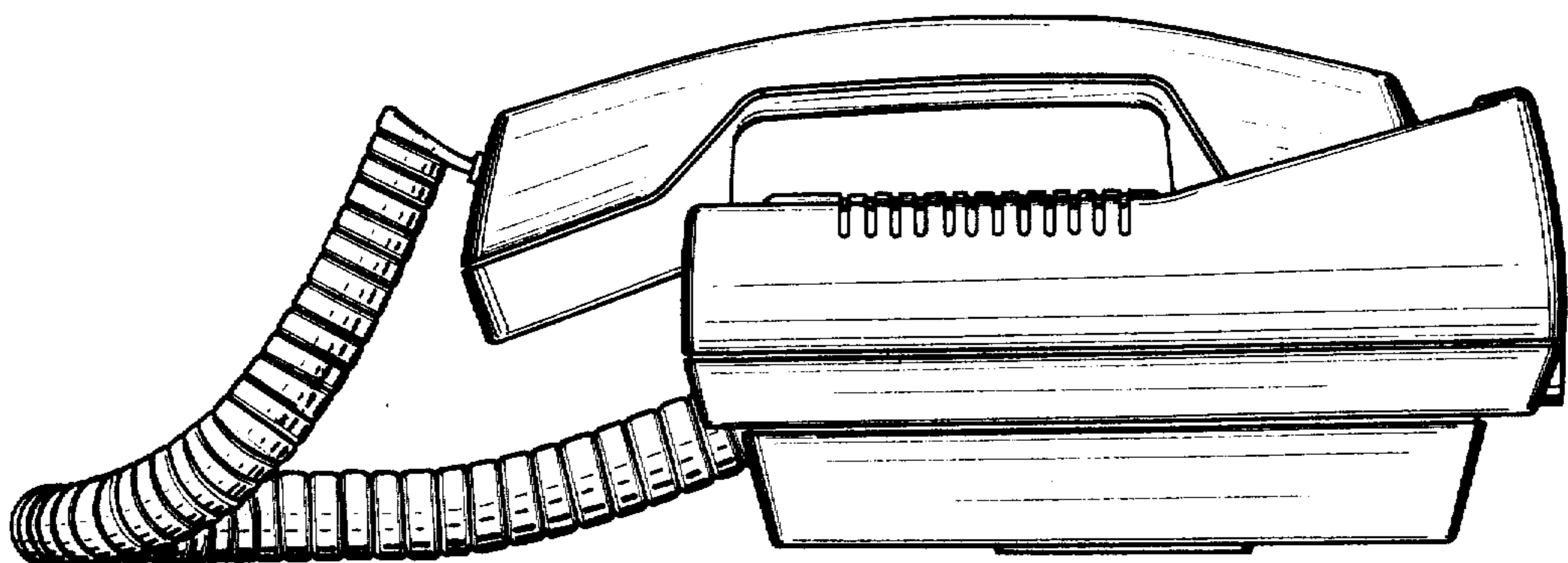

FIG. 5

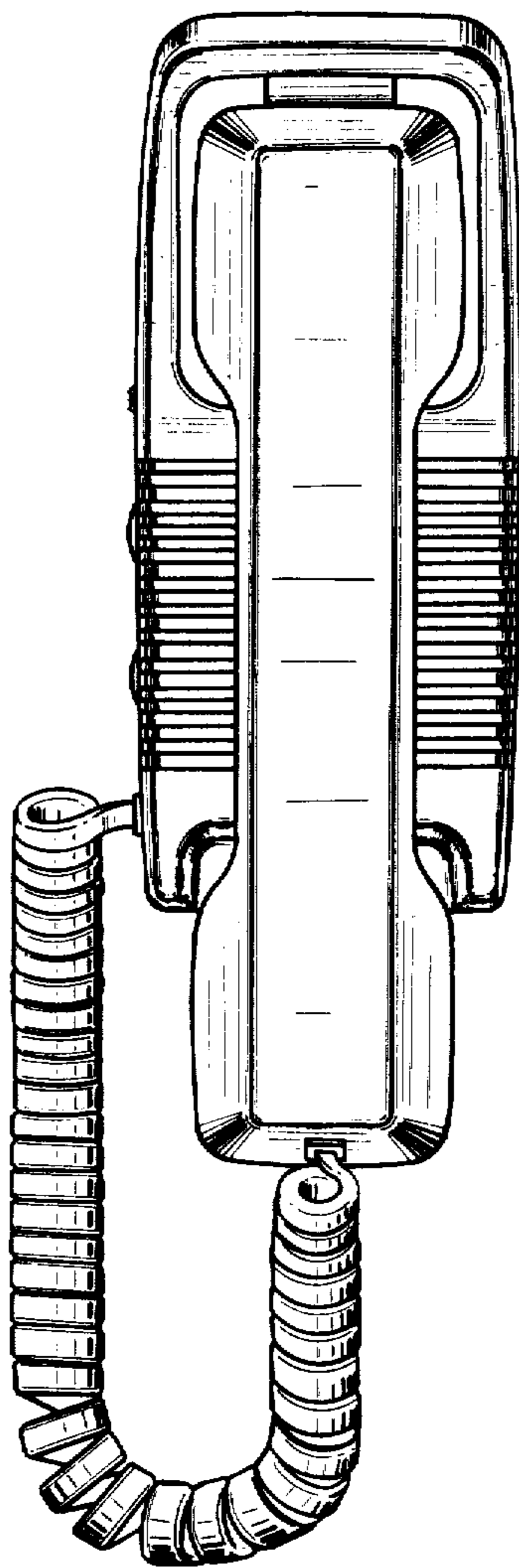

FIG. 6

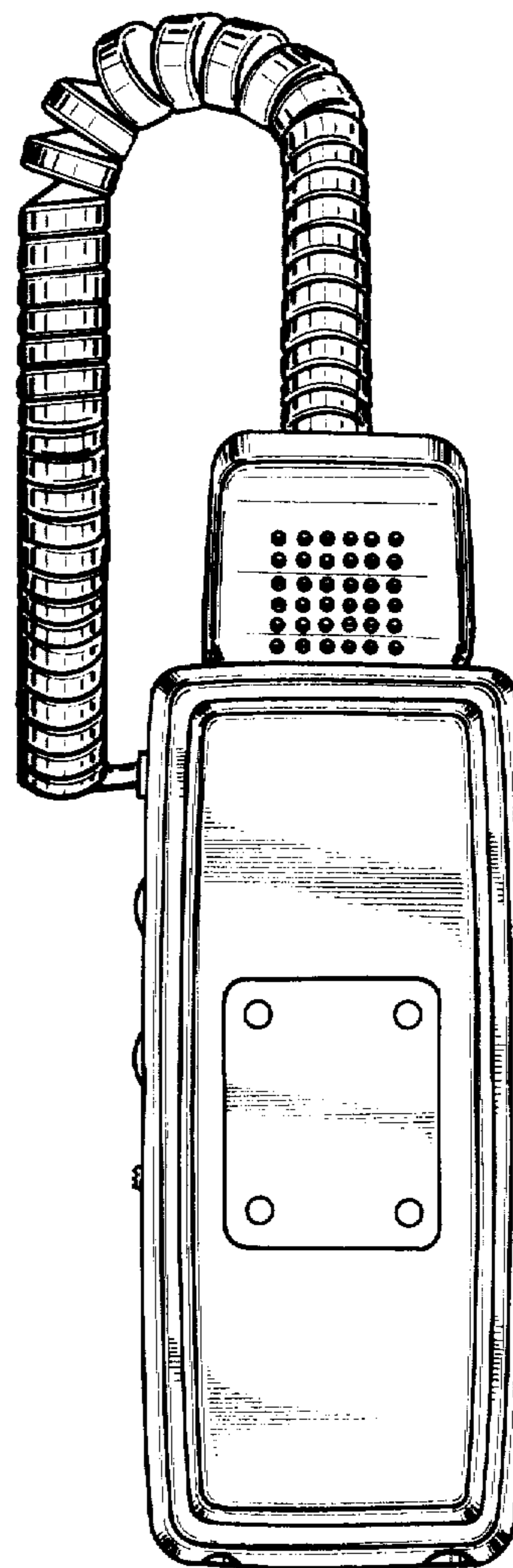

FIG. 7

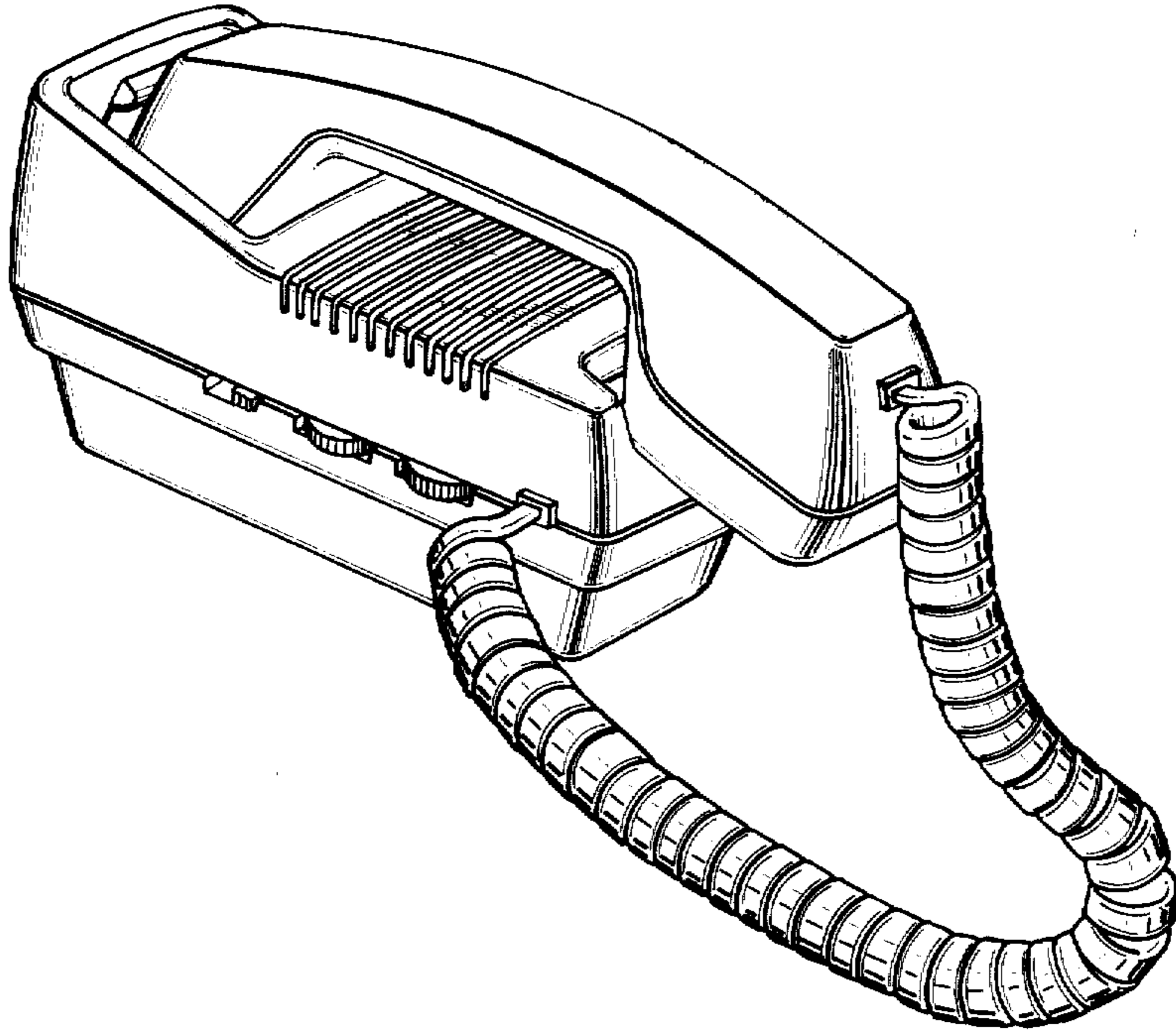

FIG. 8

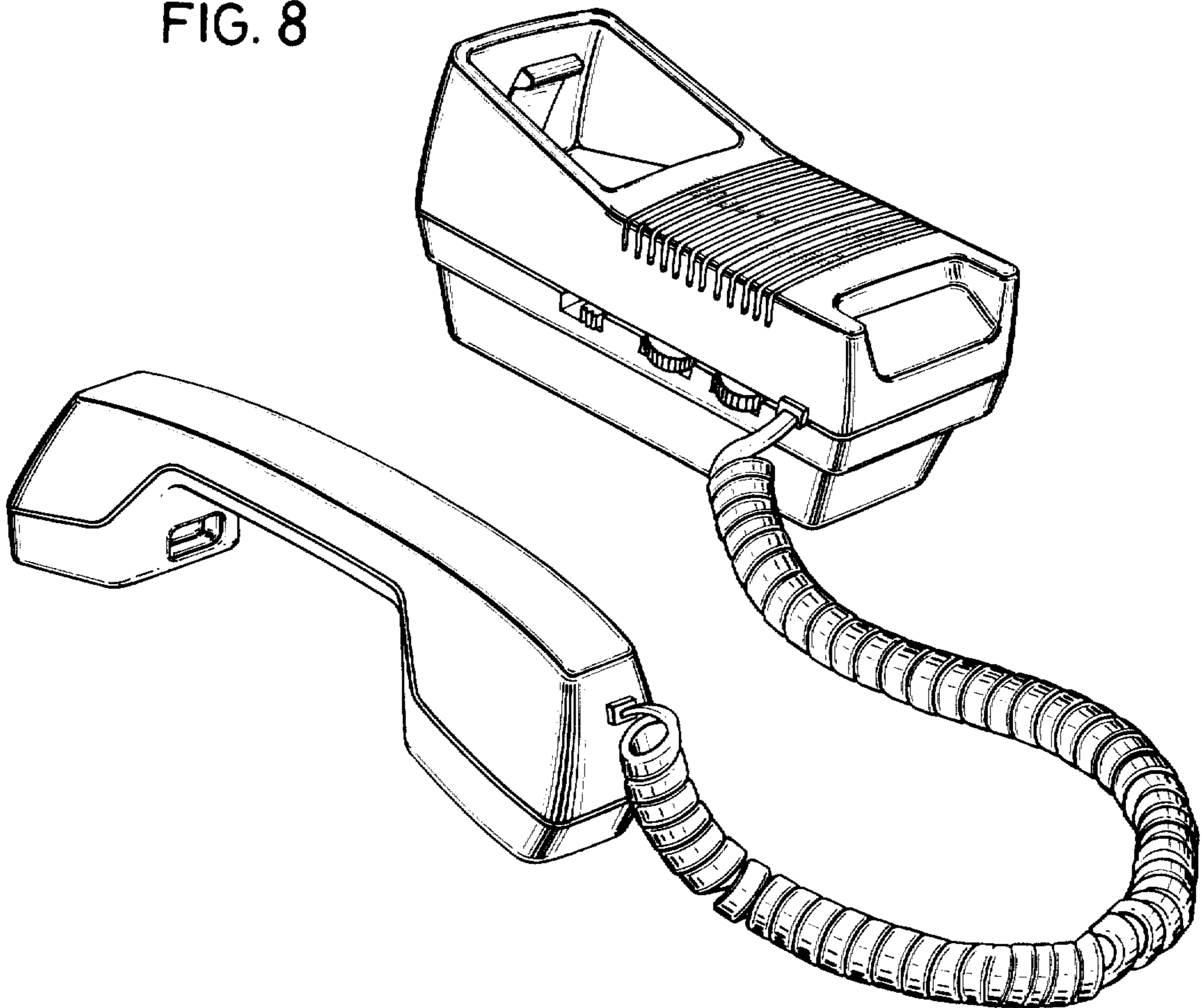

FIG. 9

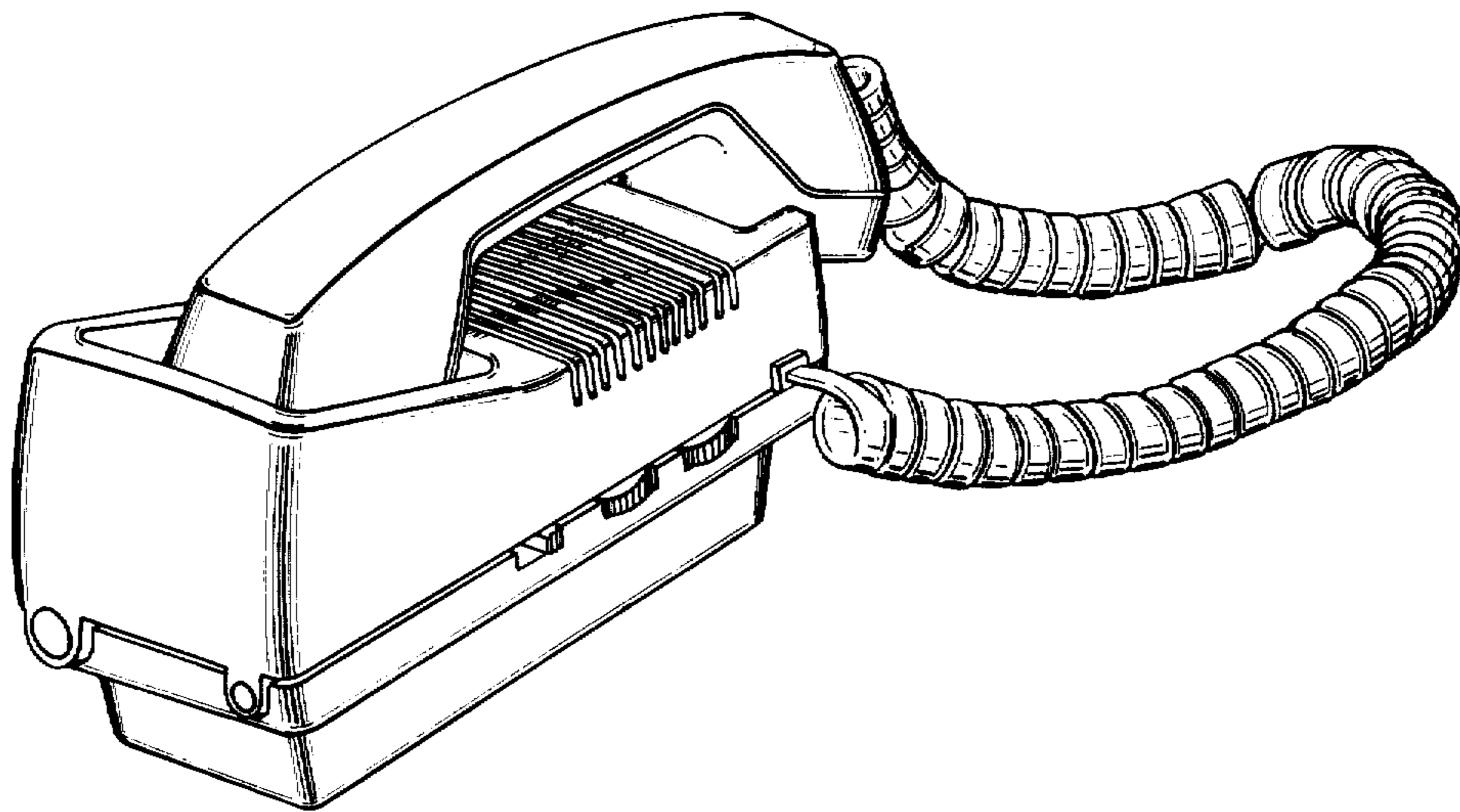

FIG. 10

