

[54] HEAT LAMP STAND

3,262,703 7/1966 Hodlick ..... 248/158 X

[76] Inventor: Donald F. Tripp, 461 Butterfield, East Lansing, Mich. 48823

FOREIGN PATENT DOCUMENTS

826158 12/1937 France ..... 248/122

[\*\*] Term: 14 Years

Primary Examiner—Susan J. Lucas  
Attorney, Agent, or Firm—Ian C. McLeod

[21] Appl. No.: 182,776

[57] CLAIM

[22] Filed: Aug. 29, 1980

The ornamental design for a heat lamp stand, as shown and described.

[51] Int. Cl. .... D24—99; D26—05

[52] U.S. Cl. .... D24/68; D26/63; D26/138

[58] Field of Search ..... 362/250, 285, 410, 413, 362/414, 418, 427, 431; 250/494; D26/61, 63, 93, 138, 142, 145, 148; D24/68; 248/121, 122, 158

DESCRIPTION

FIG. 1 is a left side elevational view of a heat lamp stand showing my new design.

FIG. 2 is a front elevational view of the stand as shown in FIG. 1.

FIG. 3 is a right side elevational view of the stand as shown in FIG. 2.

FIG. 4 is a rear elevational view of the stand as shown in FIG. 2.

FIG. 5 is a top plan view.

FIG. 6 is a bottom plan view.

The heat lamp are shown in broken lines for illustrative purposes only.

[56] References Cited

U.S. PATENT DOCUMENTS

D. 197,908	4/1964	Chaffee	.....	D24/68
1,195,032	8/1916	Lamb	.....	362/414
1,744,635	1/1930	Holder	.....	248/158
3,084,258	4/1963	Furedy	.....	250/494

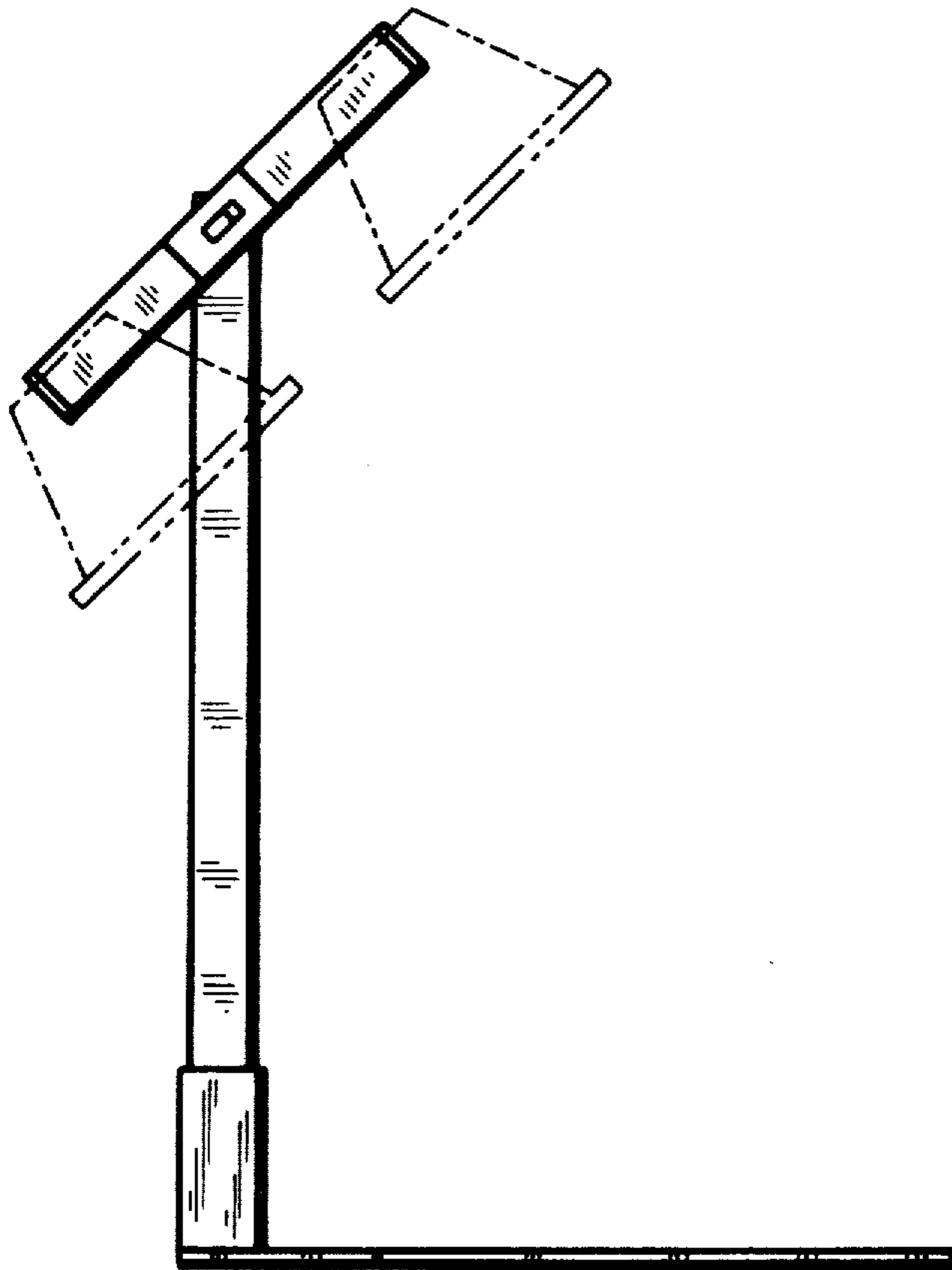

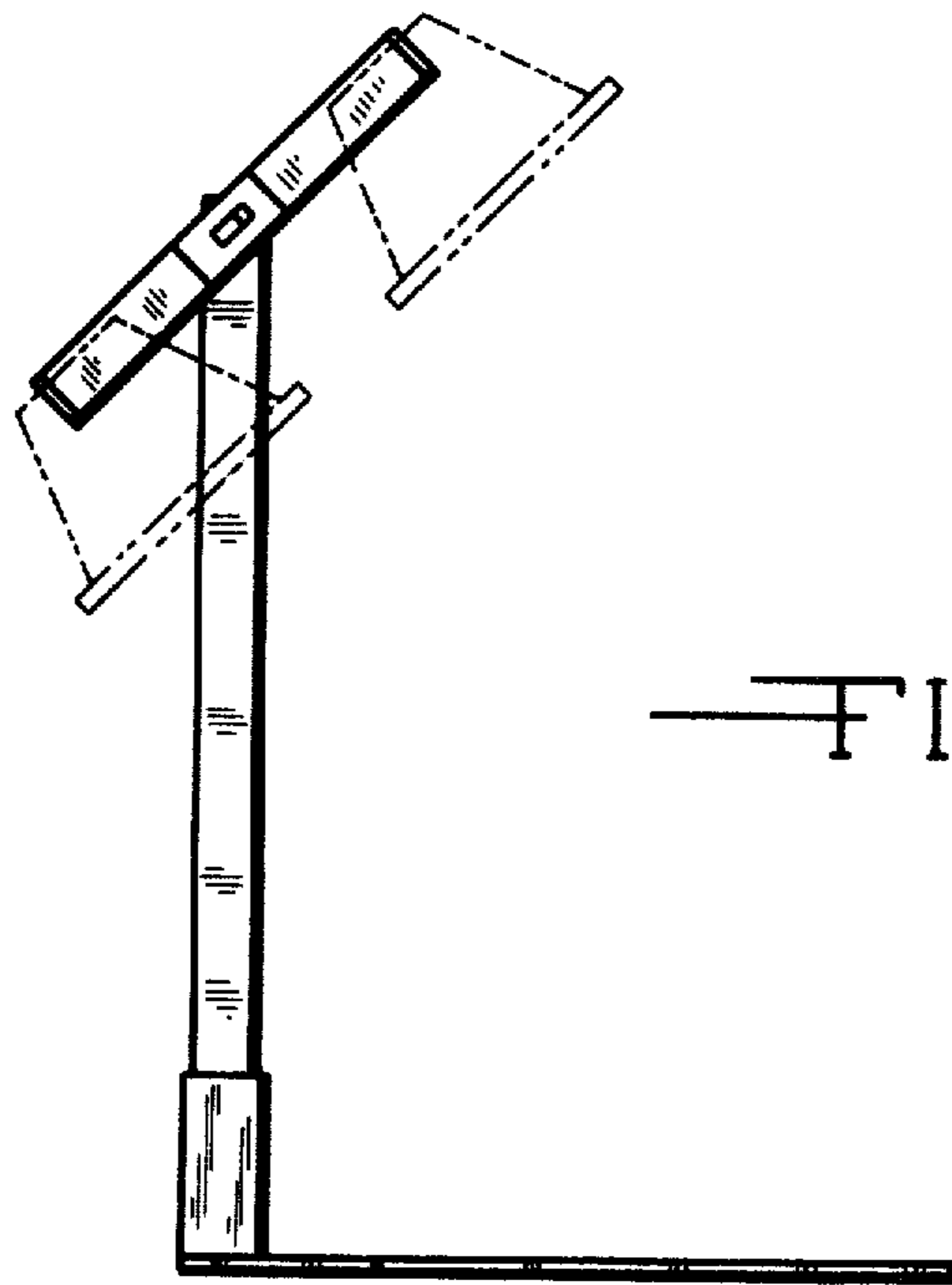

—FIG. 1

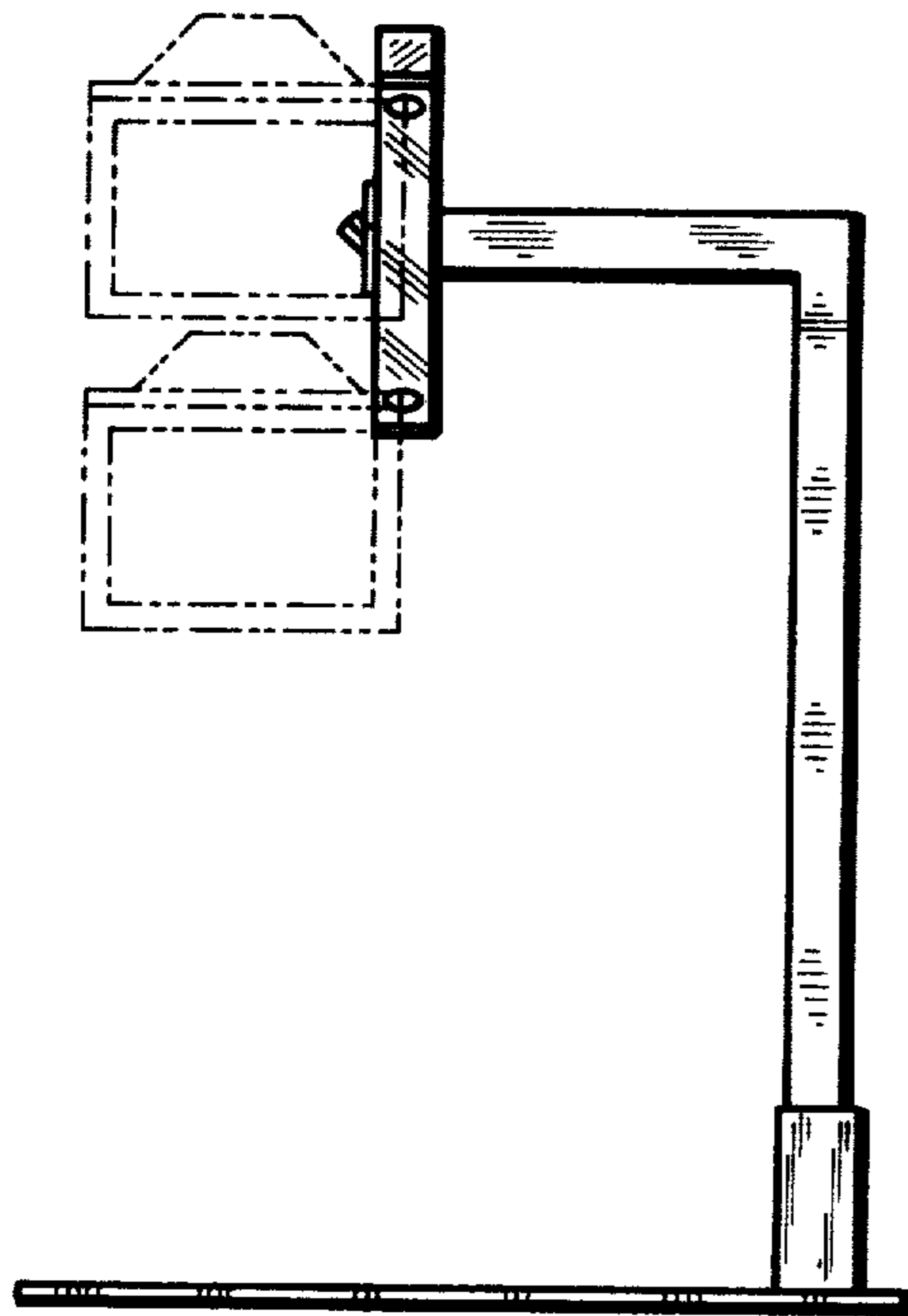

—FIG. 2

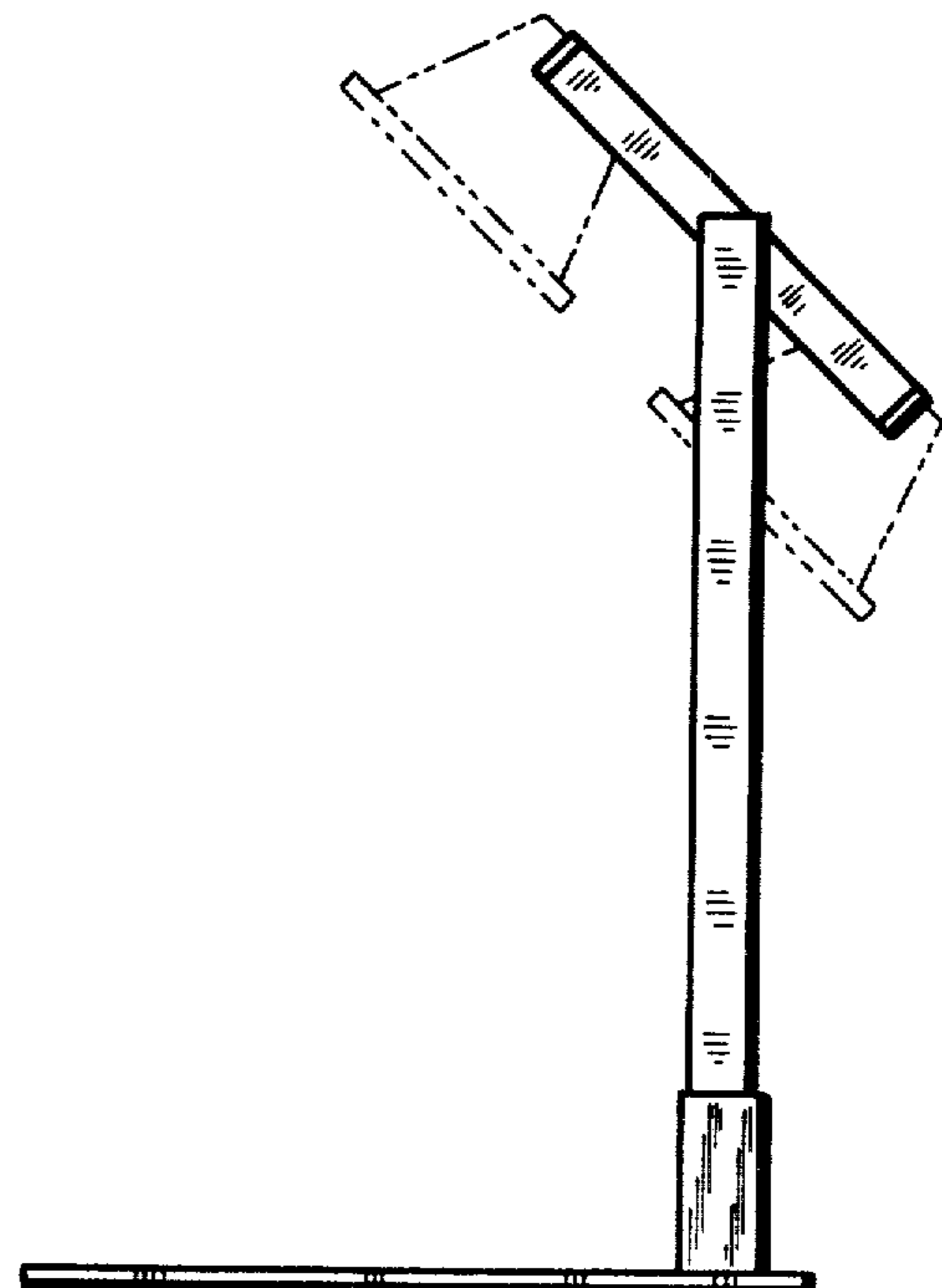

—FIG. 3

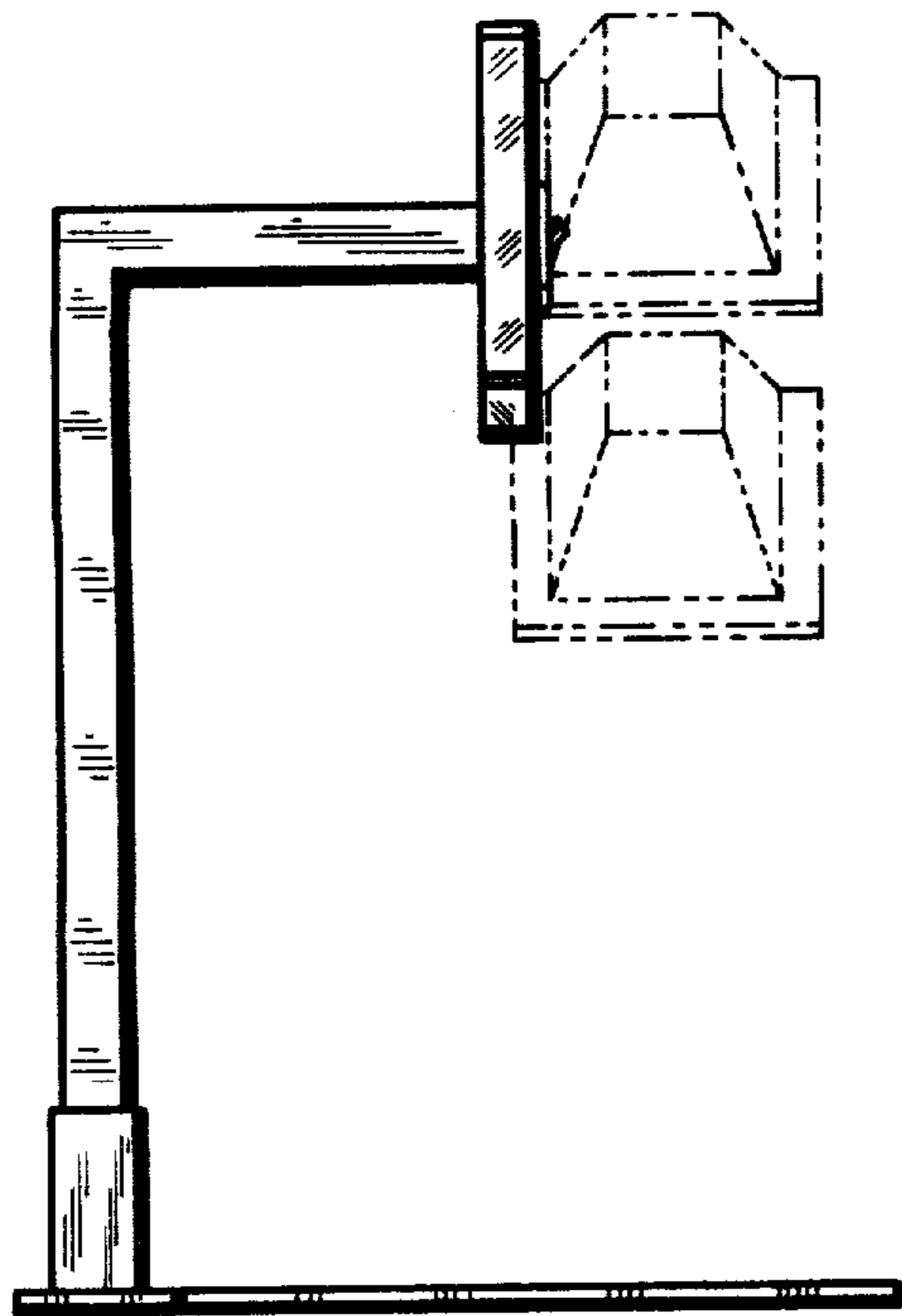

—FIG. 4

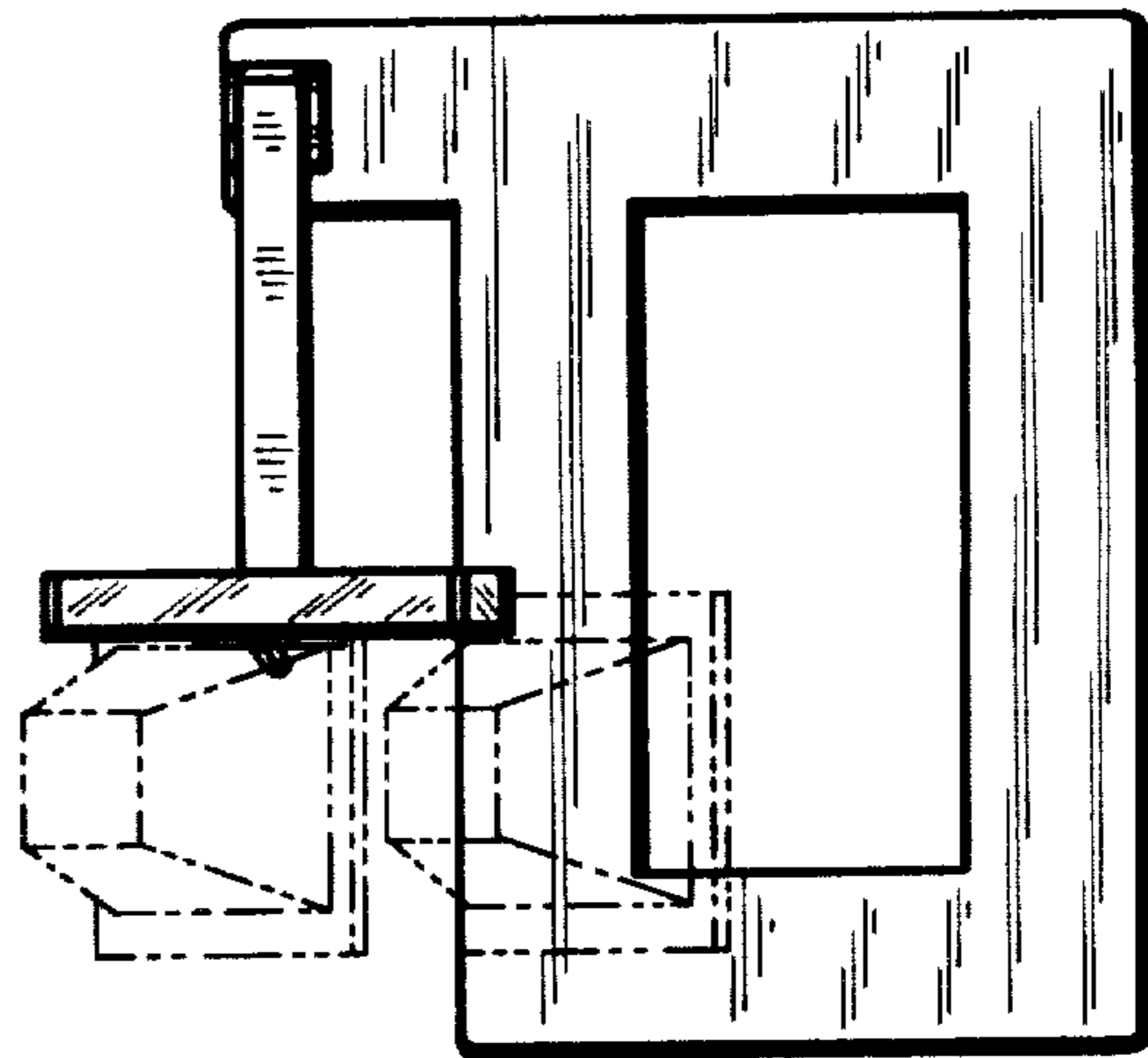

—FIG. 5

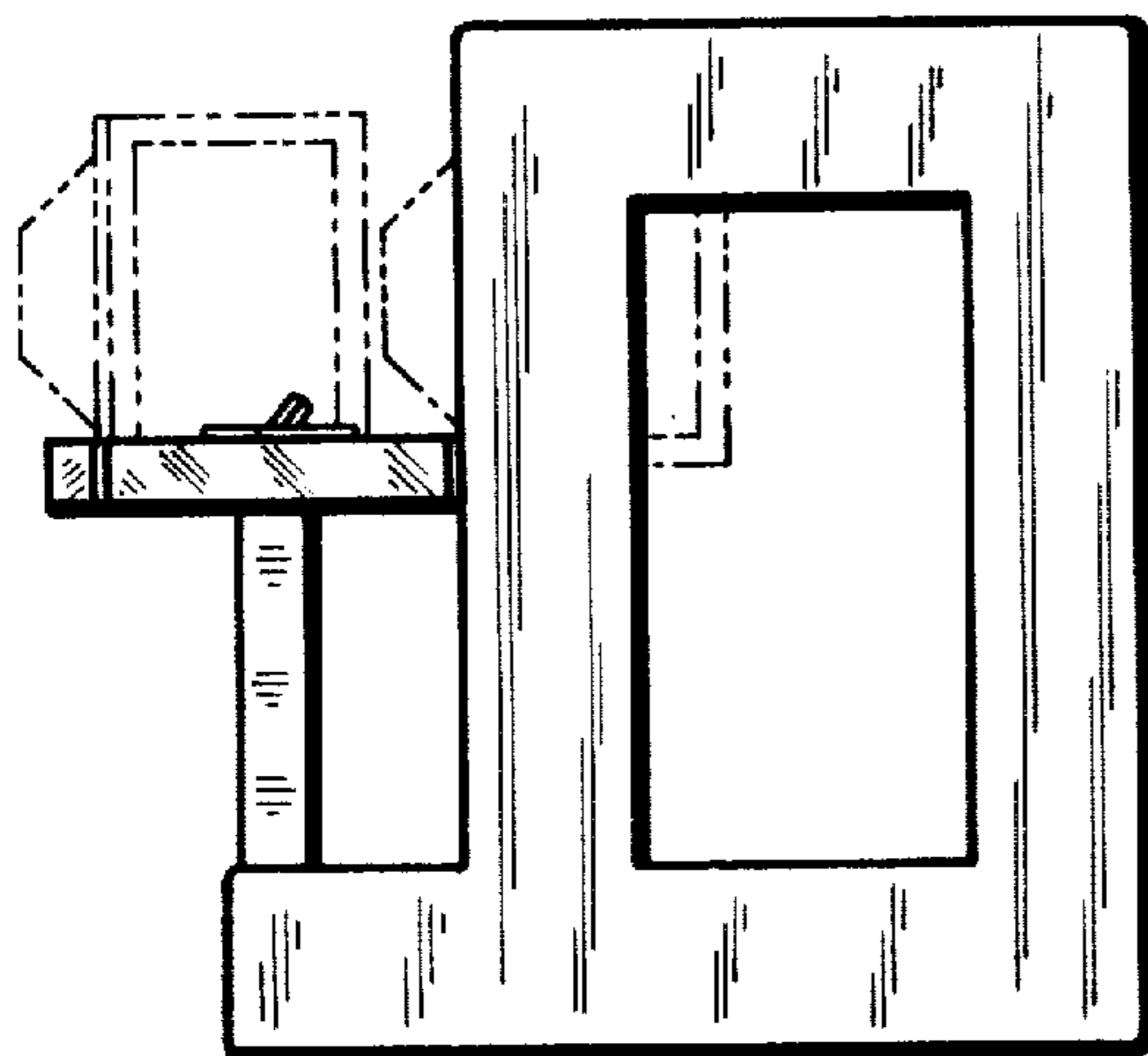

—FIG. 6