

[54] **AIRCRAFT DESIGN**

[75] **Inventor:** Hubert Krojer, Bermatingen, Fed. Rep. of Germany

[73] **Assignee:** Dornier GmbH, Fed. Rep. of Germany

[\*\*] **Term:** 14 Years

[21] **Appl. No.:** 104,708

[22] **Filed:** Dec. 17, 1979

[51] **Int. Cl.** ..... D12-07

[52] **U.S. Cl.** ..... D12/337; D12/319; D12/340; D12/343

[58] **Field of Search** ..... D12/319, 331, 337, 340, D12/341, 343; 244/55, 13, 15, 106

[56] **References Cited**

**U.S. PATENT DOCUMENTS**

D. 138,538	8/1944	Clerc .....	244/55
D. 158,634	5/1950	Paker et al. ....	D12/333
D. 205,563	8/1966	Flock .....	D12/337
D. 236,100	7/1975	Heald et al. ....	D12/337
3,362,659	1/1968	Razak .....	D12/332

*Primary Examiner*—T. Tung

*Attorney, Agent, or Firm*—James E. Bryan

[57] **CLAIM**

The ornamental aircraft design, substantially as shown and described.

**DESCRIPTION**

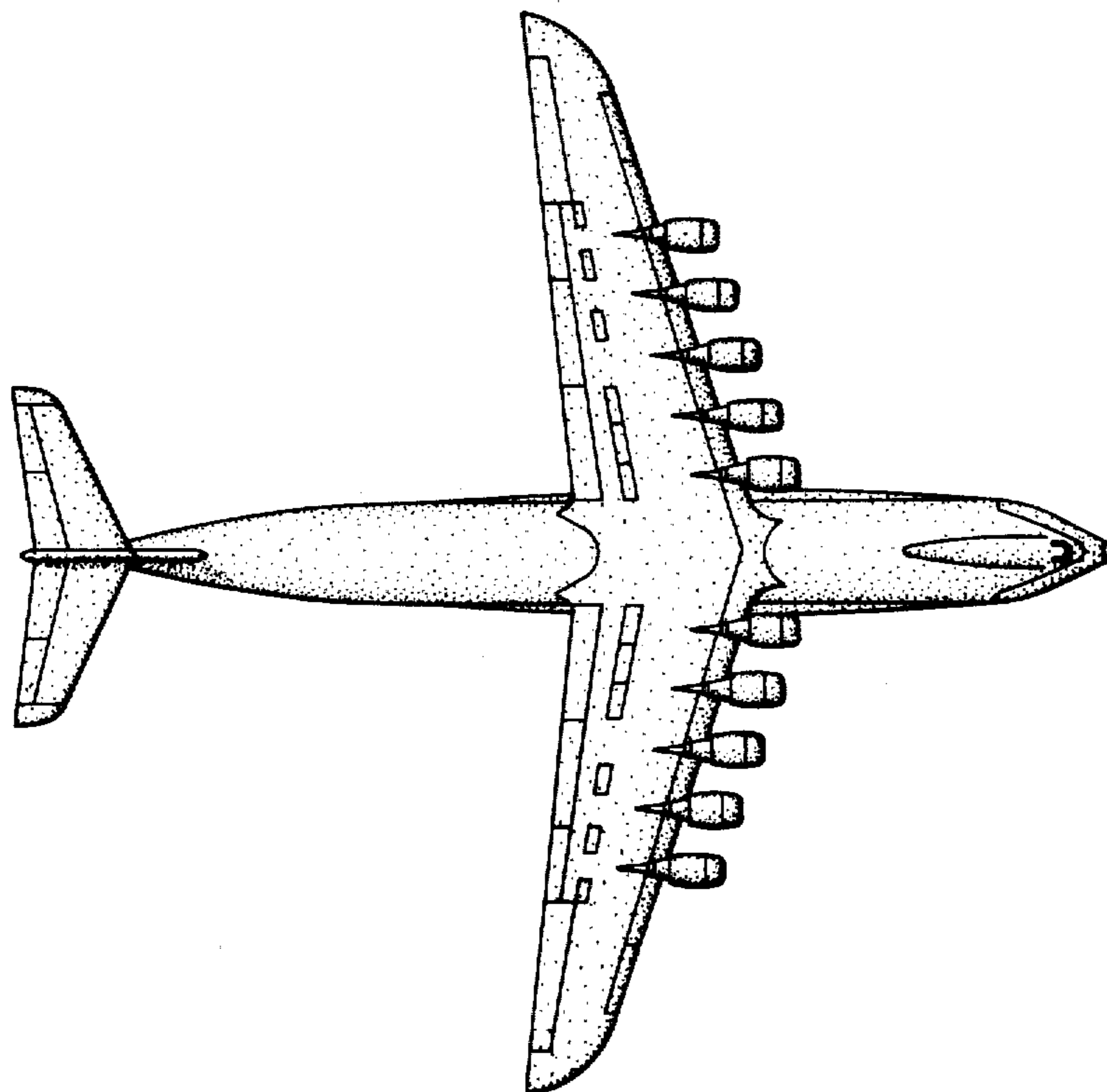
FIG. 1 is a side view in elevation showing my aircraft design,

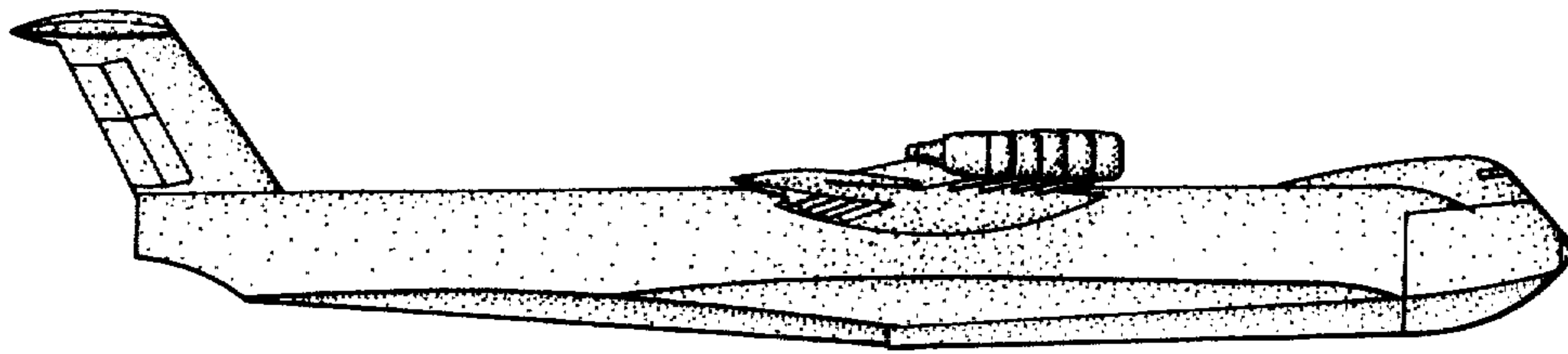
FIG. 2 is a top plan view thereof,

FIG. 3 is a front view thereof,

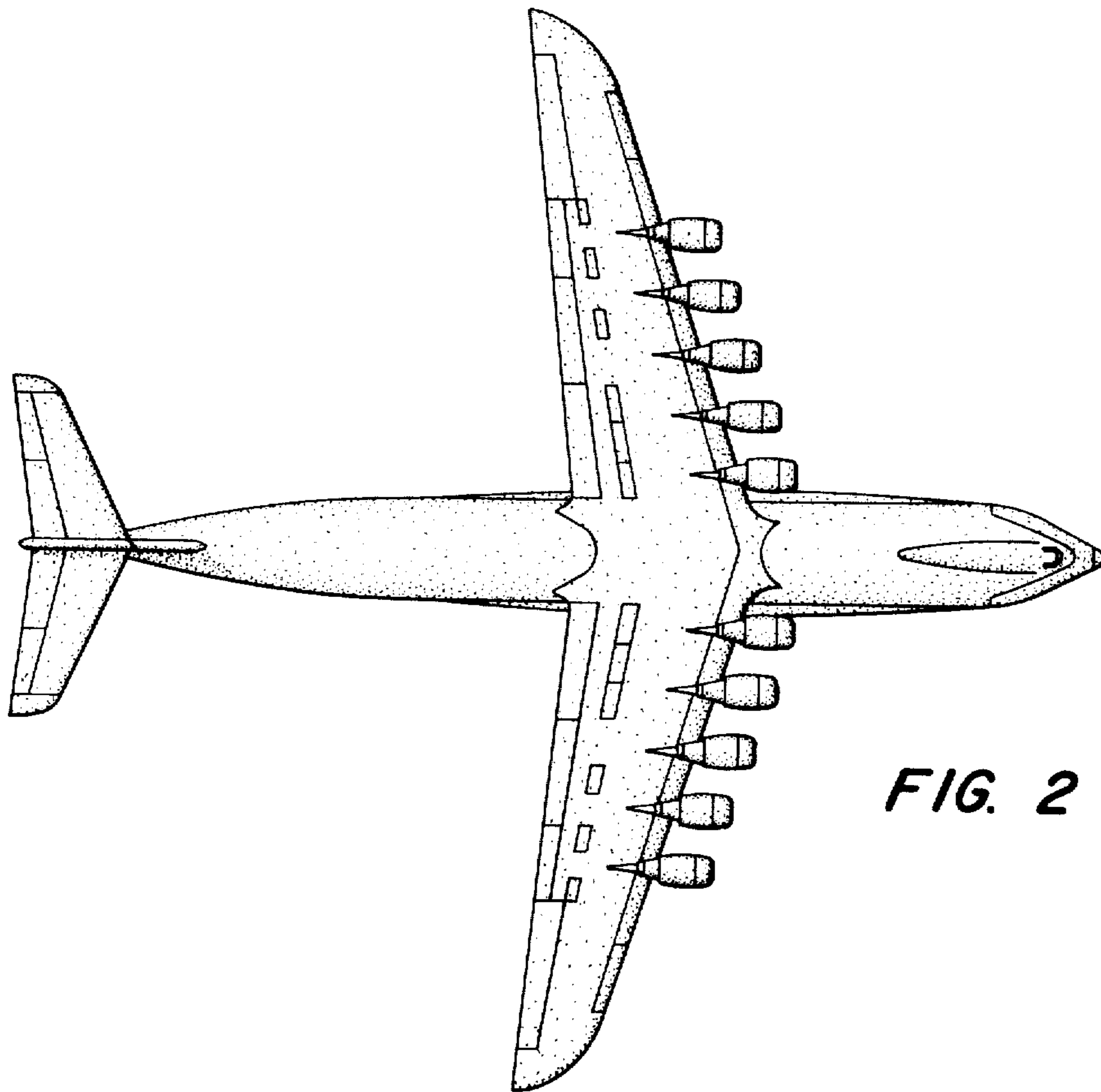
FIG. 4 is a bottom view thereof, and

FIG. 5 is a rear view thereof.

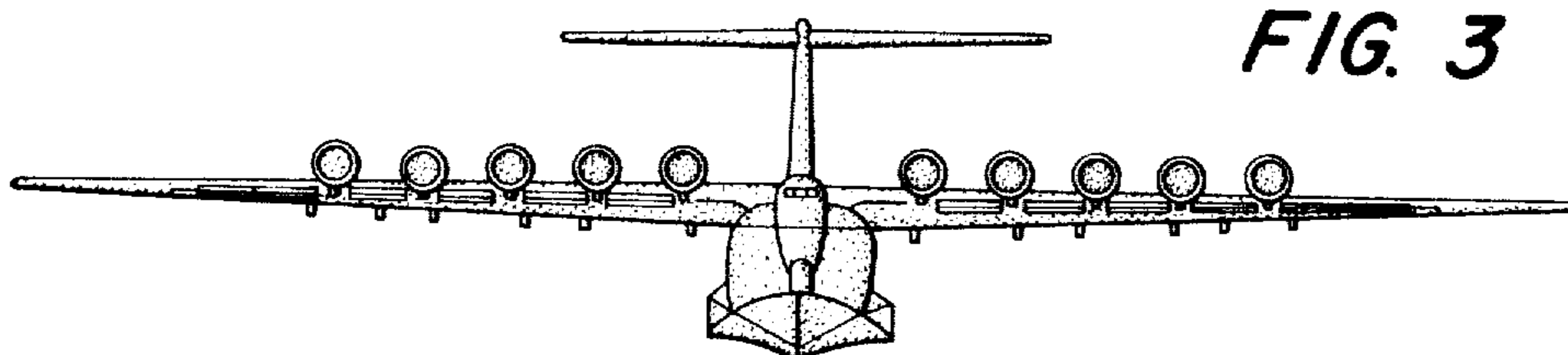




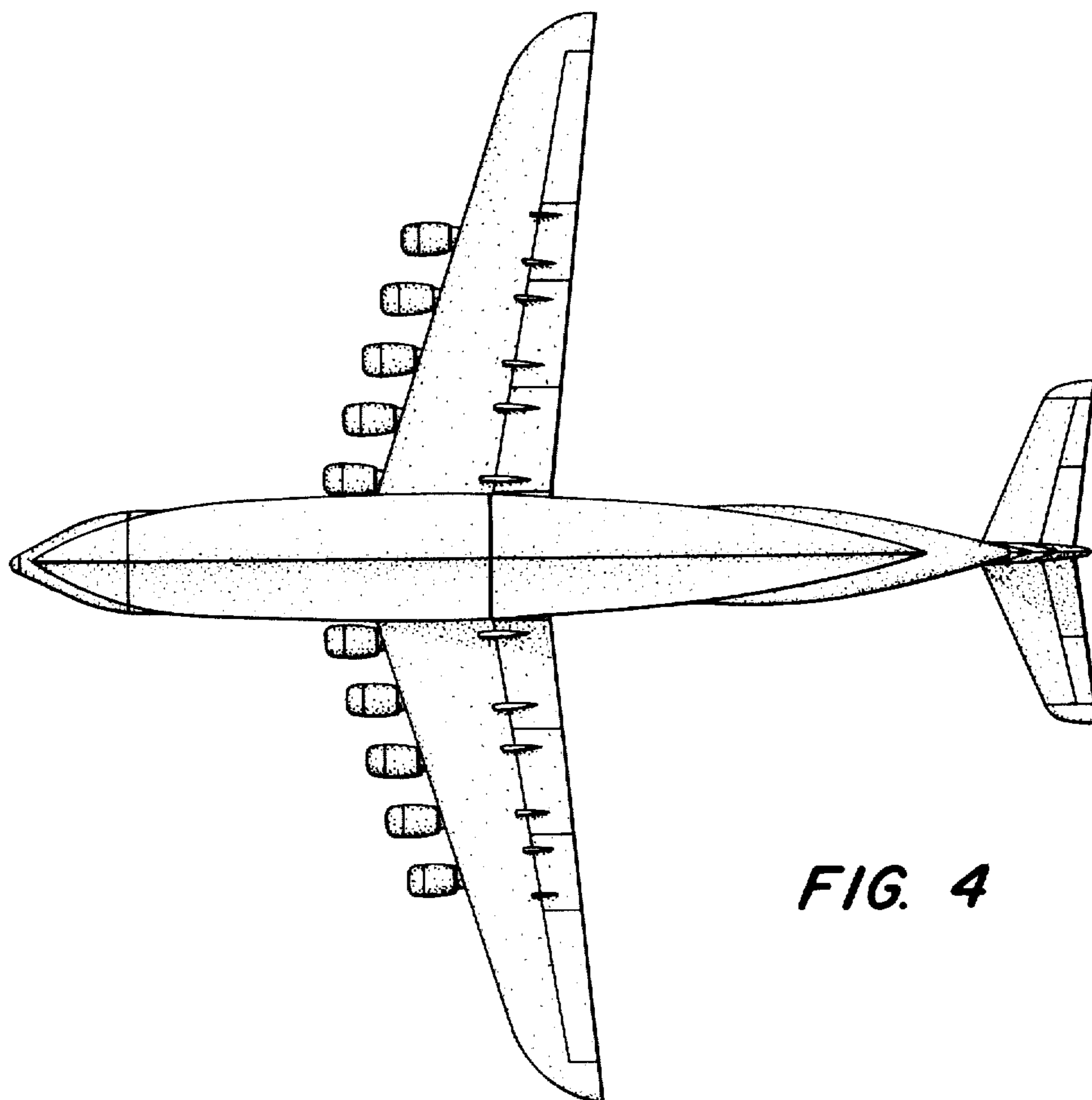
*FIG. 1*



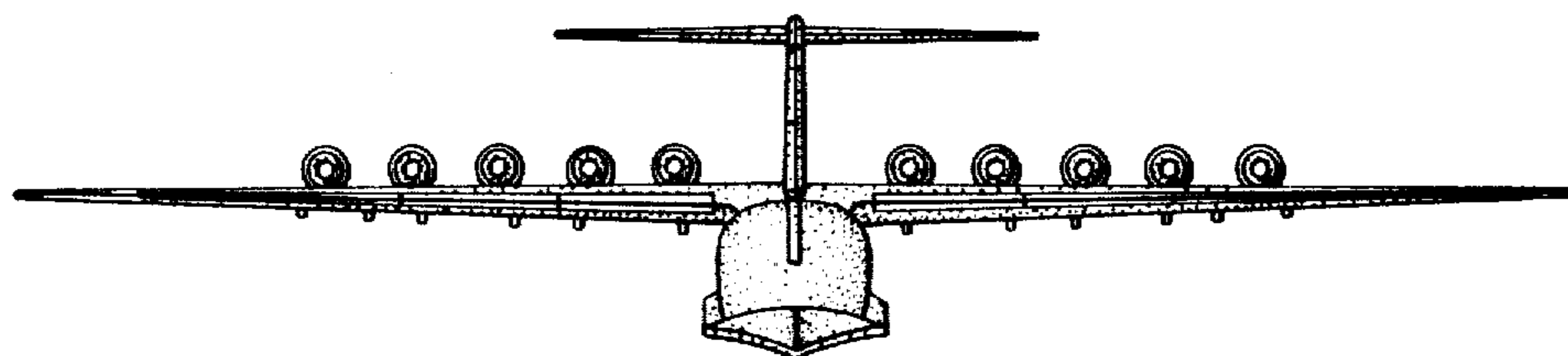
*FIG. 2*



*FIG. 3*



**FIG. 4**



**FIG. 5**