

[54] VEHICLE ARTICLE CARRIER

[76] Inventor: Bruno Urban, 520 S. Courtland, Park Ridge, Ill. 60068

[**] Term: 14 Years

[21] Appl. No.: 159,233

[22] Filed: Jun. 13, 1980

[51] Int. Cl. D12-16

[52] U.S. Cl. D3/40

[58] Field of Search D3/40; D12/155; 224/42.42; 296/37.8, 37.16, 37.13; D6/130, 131

[56] References Cited

U.S. PATENT DOCUMENTS

- D. 33,081 8/1900 Macker D3/40
- D. 249,672 9/1978 VanderWaal D12/155

OTHER PUBLICATIONS

J. C. Whitney Catalog No. 8C, ©1979, p. 49, Truck Cab Organizer, bottom right side of page.

Primary Examiner—James M. Gandy
Attorney, Agent, or Firm—Hume, Clement, Brinks, Willian & Olds, Ltd.

[57] CLAIM

The ornamental design for a vehicle article carrier, substantially as shown and described.

DESCRIPTION

FIG. 1 is a perspective view of a vehicle article carrier showing my new design;
 FIG. 2 is a front elevational view thereof;
 FIG. 3 is a side elevational view thereof;
 FIG. 4 is a top plan view thereof;
 FIG. 5 is a rear elevational thereof;
 FIG. 6 is a perspective view of a vehicle article carrier showing a second embodiment of my new design;
 FIG. 7 is a front elevational view of the embodiment of FIG. 6;
 FIG. 8 is a side elevational view of the embodiment of FIG. 6;
 FIG. 9 is a top plan view of the embodiment of FIG. 6; and
 FIG. 10 is a rear elevational view of the embodiment of FIG. 6.
 FIGS. 1 and 6 show the respective embodiments as installed at the inside rear wall of the cab of an automotive vehicle.
 FIGS. 2 through 5 and 7 through 10 show the respective embodiments in flat condition.
 The broken lines showing the frames of the rear window and side door of the vehicle in FIGS. 1 and 6 are understood to be for illustrative purposes only, and the broken lines on the surface of the article carrier shown in FIGS. 1, 2, 6 and 7 represent stitching.

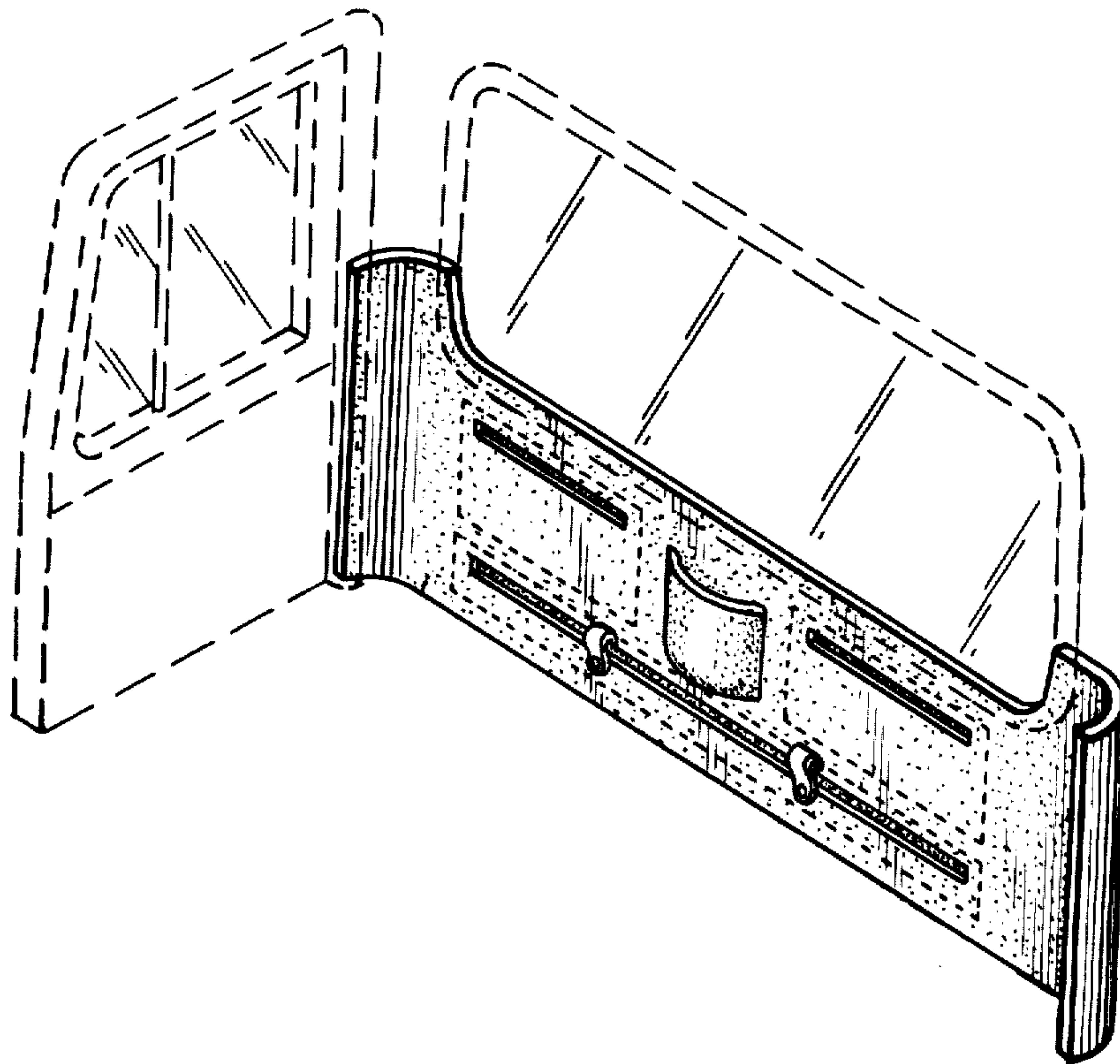

FIG. 3



FIG. 1

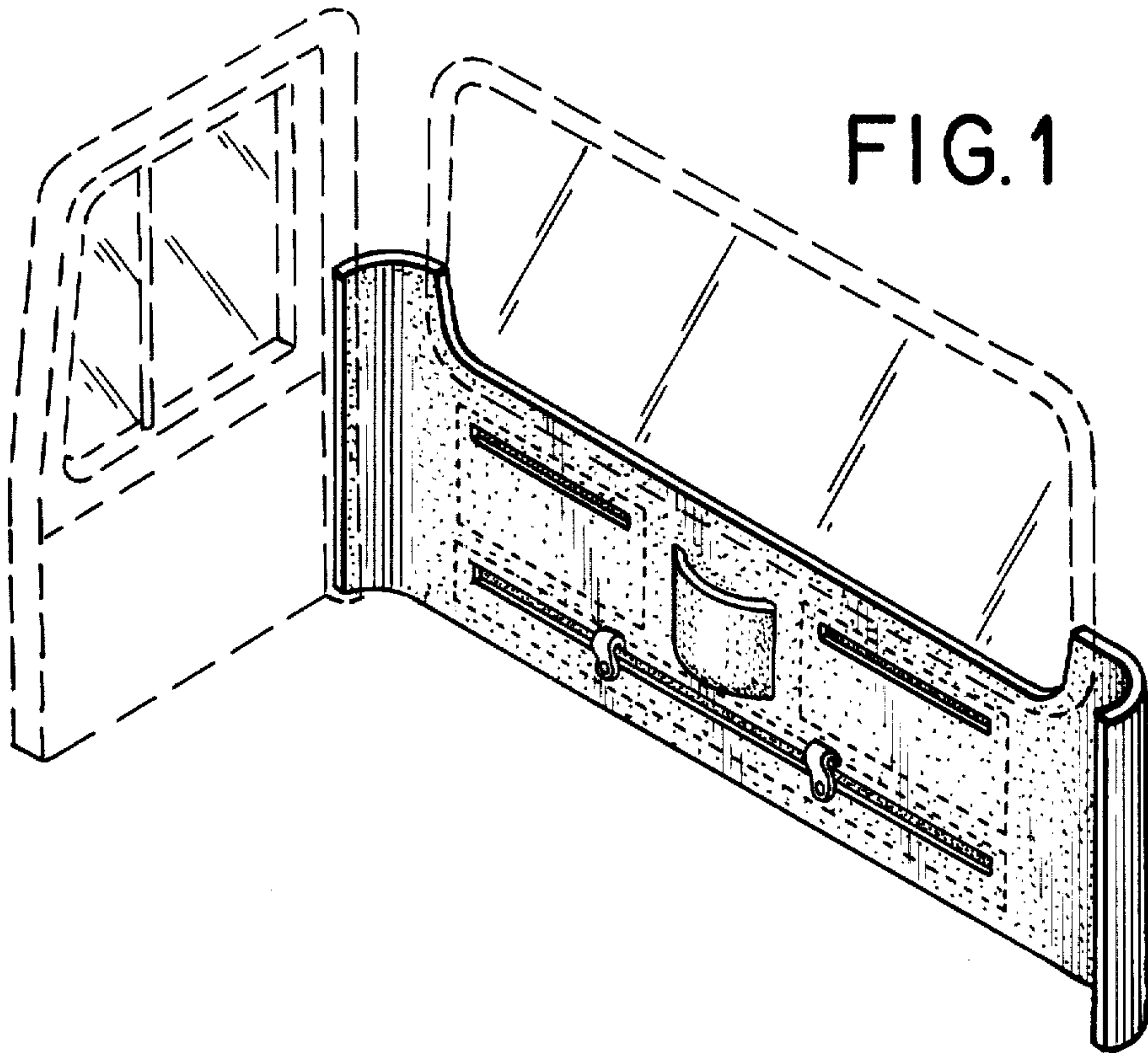

FIG. 2

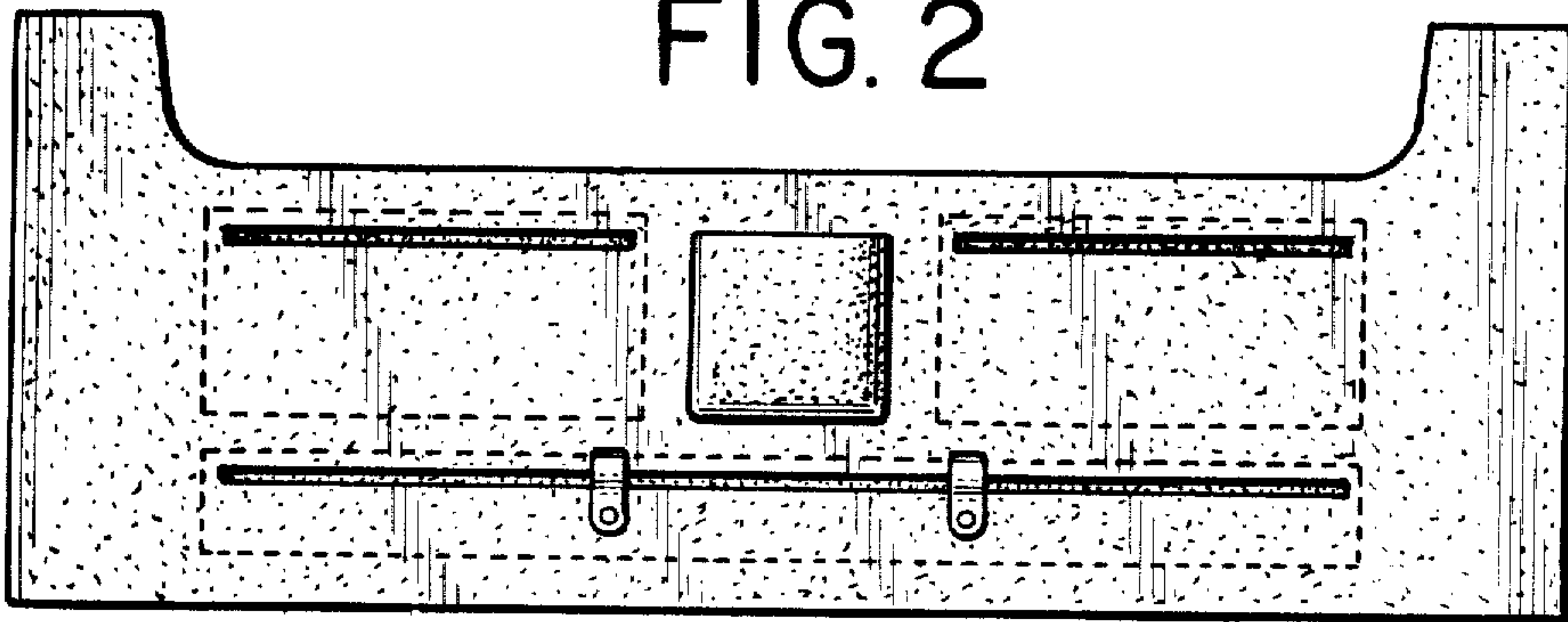

FIG. 4



FIG. 5

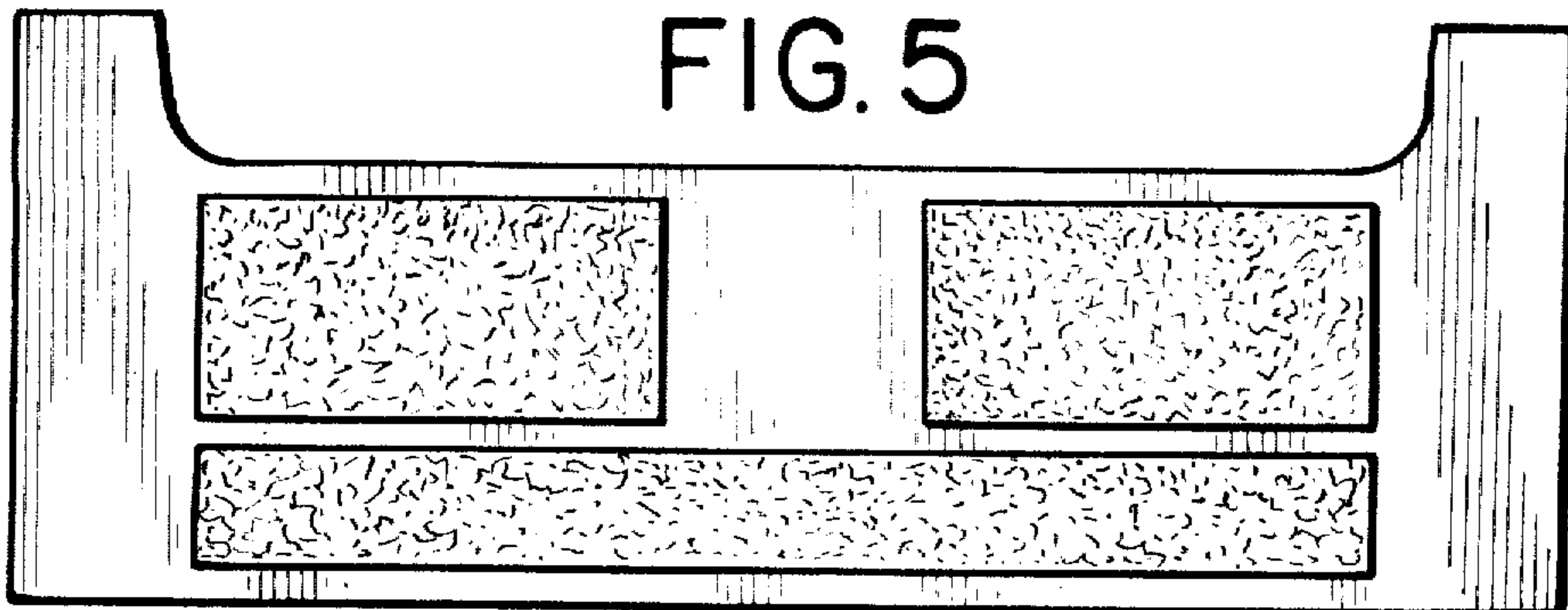

FIG. 8



FIG. 6

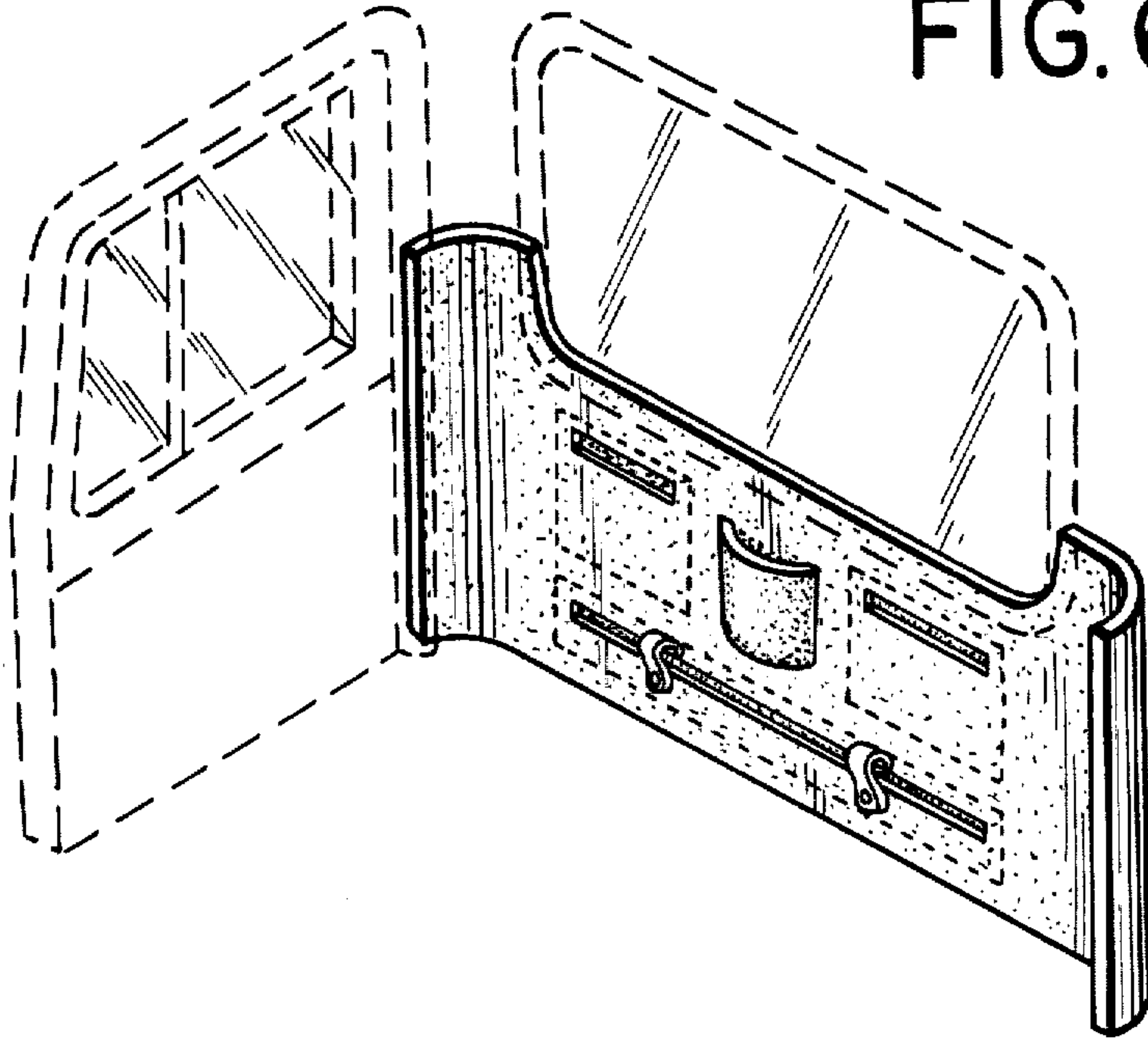

FIG. 7

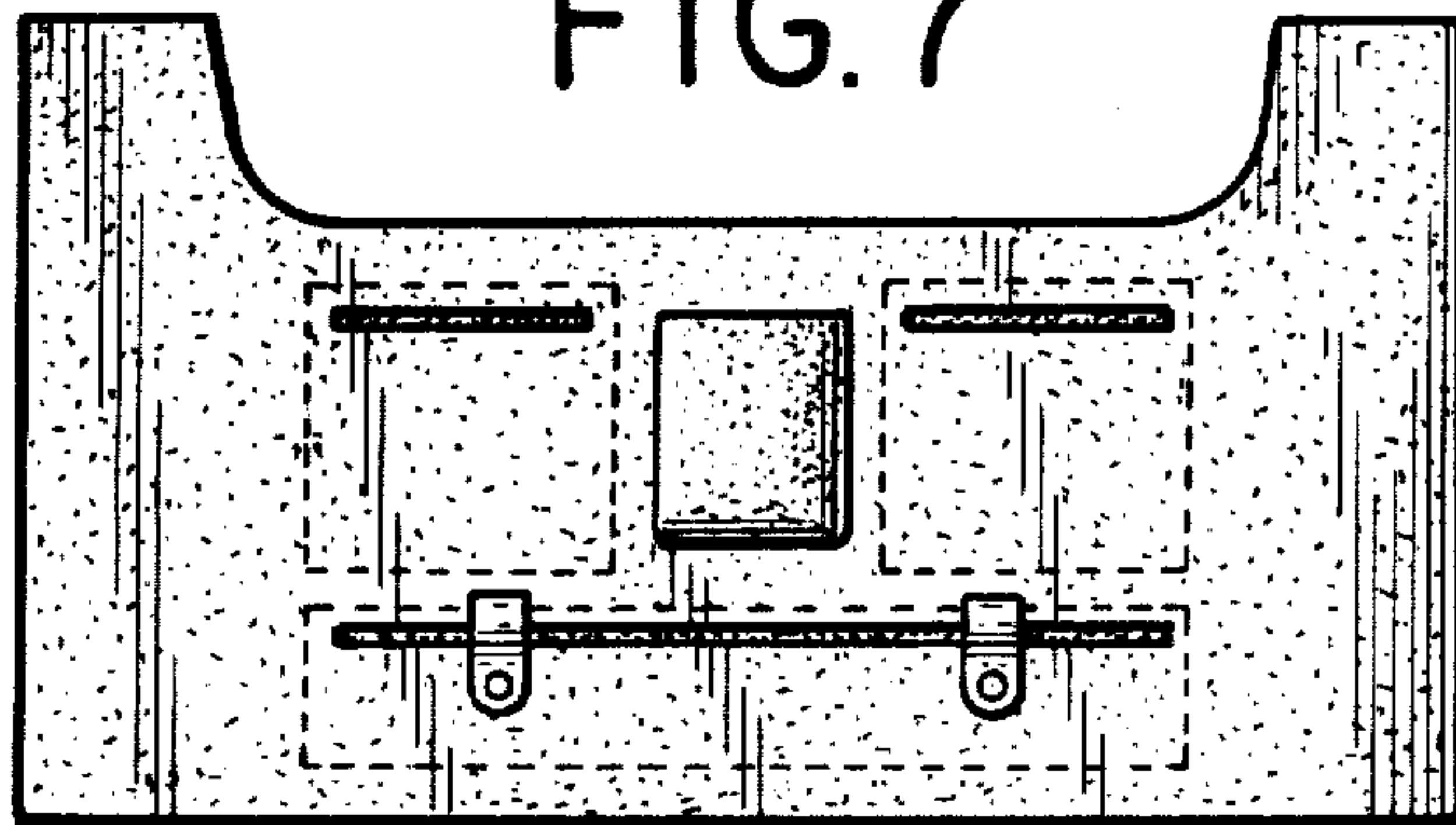

FIG. 9



FIG. 10

