

- [54] DOCUMENTATION HANGER BAR FOR LIBRARY STORAGE UNIT
- [75] Inventors: Frederick J. Moriarty, Worcester; Edmund T. Paquette, Shrewsbury, both of Mass.
- [73] Assignee: Wright Line Inc., Worcester, Mass.
- [**] Term: 14 Years
- [21] Appl. No.: 134,706
- [22] Filed: Mar. 27, 1980
- [51] Int. Cl. D6-06
- [52] U.S. Cl. D6/191; D6/181
- [58] Field of Search D6/114, 130, 132-135, D6/181, 182, 184-186, 188-191; 108/59, 108, 114, 152; 211/134, 135, 153, 186, 187; 312/242

[56] References Cited

U.S. PATENT DOCUMENTS

- D. 193,243 7/1962 Chapman et al. D6/136
- D. 220,703 5/1971 Deguchi et al. D6/179
- 2,639,040 5/1953 Tapley D6/191 X

3,244,127 4/1966 Evans 108/108

OTHER PUBLICATIONS

Interiors, vol. 131. Sep. 1971, p. 85, Modular Shelf in right center.

Primary Examiner—Leland A. Sebastian
Attorney, Agent, or Firm—Milton E. Gilbert; Gary E. Ross

[57] CLAIM

The ornamental design for a documentation hanger bar for library storage unit, as shown and described.

DESCRIPTION

FIG. 1 is a front elevational view of a documentation hanger bar for library storage unit showing our new design;
 FIG. 2 is a right side elevational view, the left side being substantially identical thereto;
 FIG. 3 is a rear elevational view;
 FIG. 4 is a top plan view;
 FIG. 5 is a bottom plan view; and,
 FIG. 6 is a perspective view.

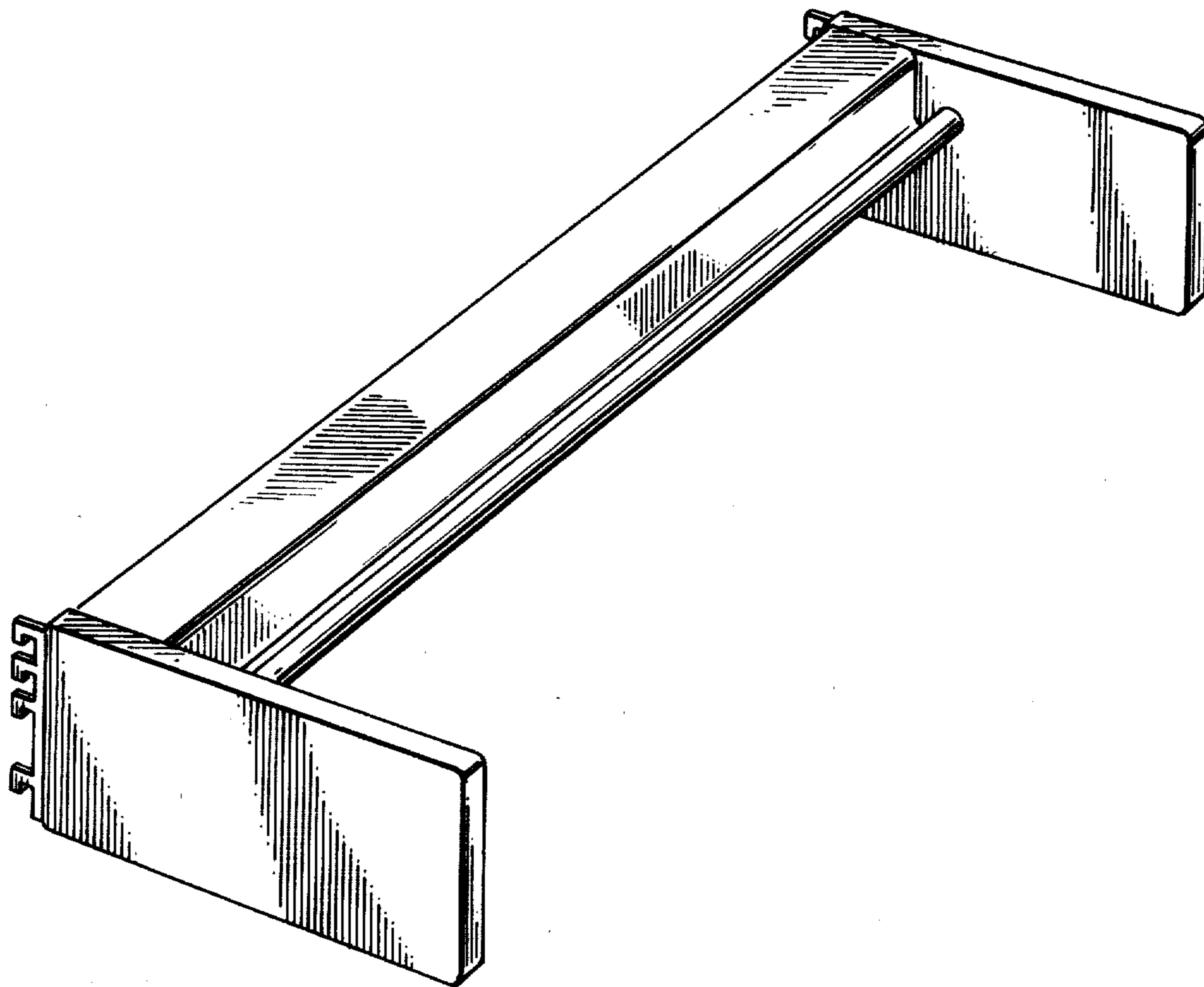

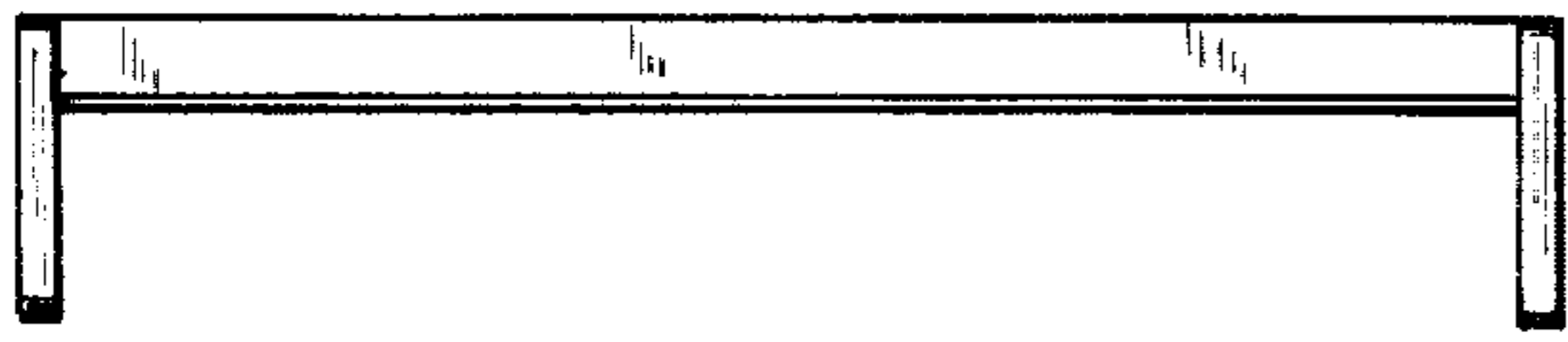

FIG. 1

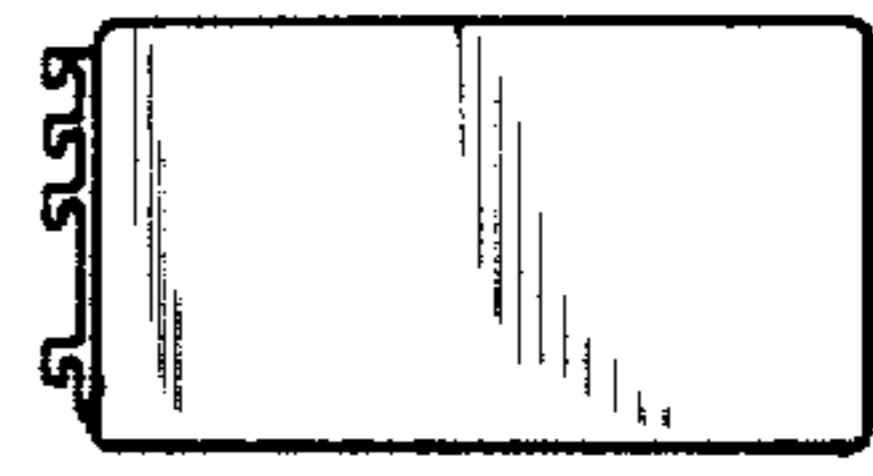

FIG. 2

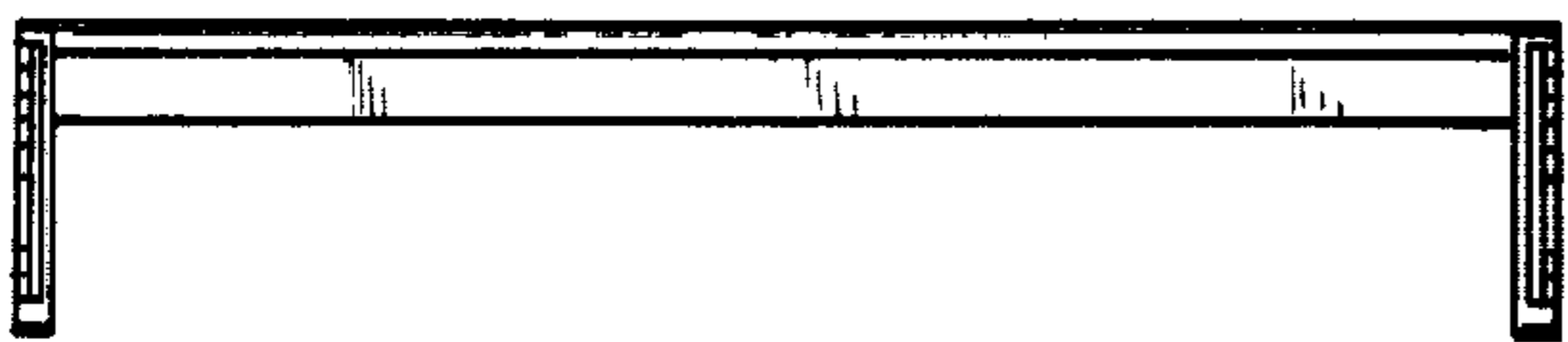

FIG. 3

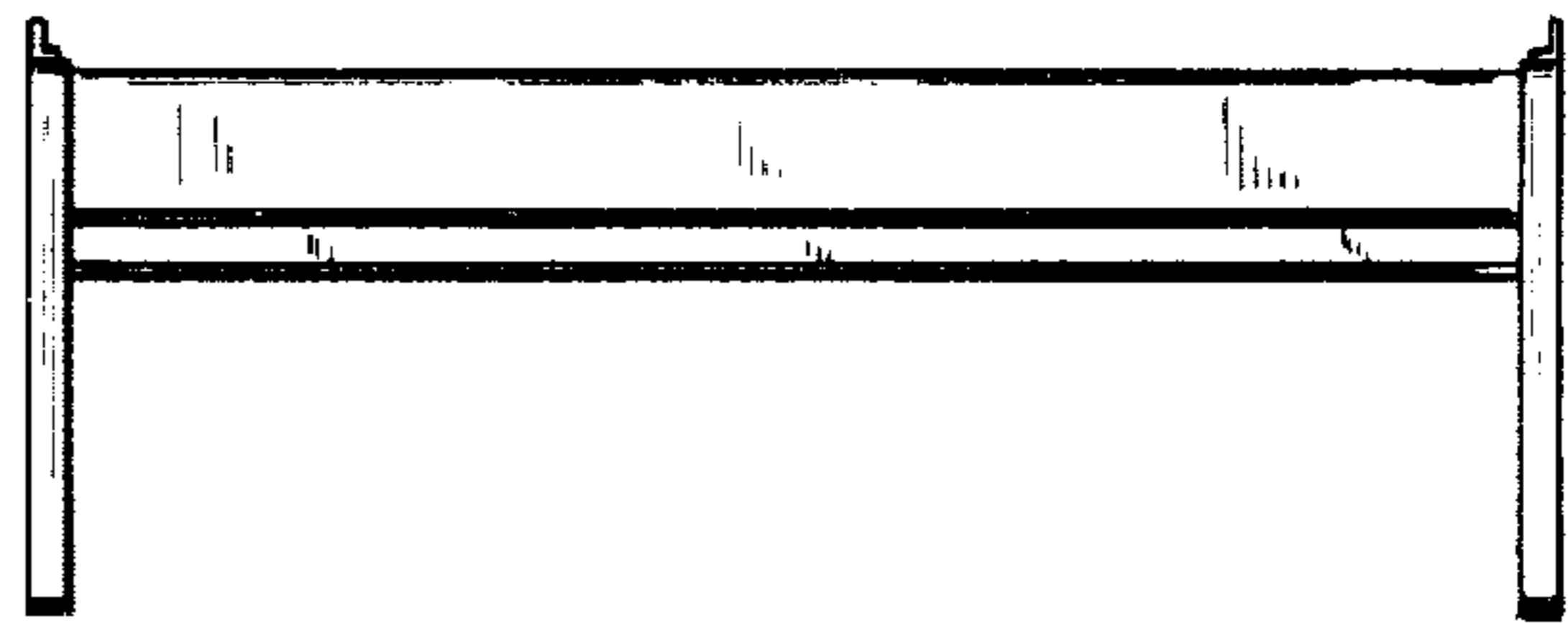

FIG. 4

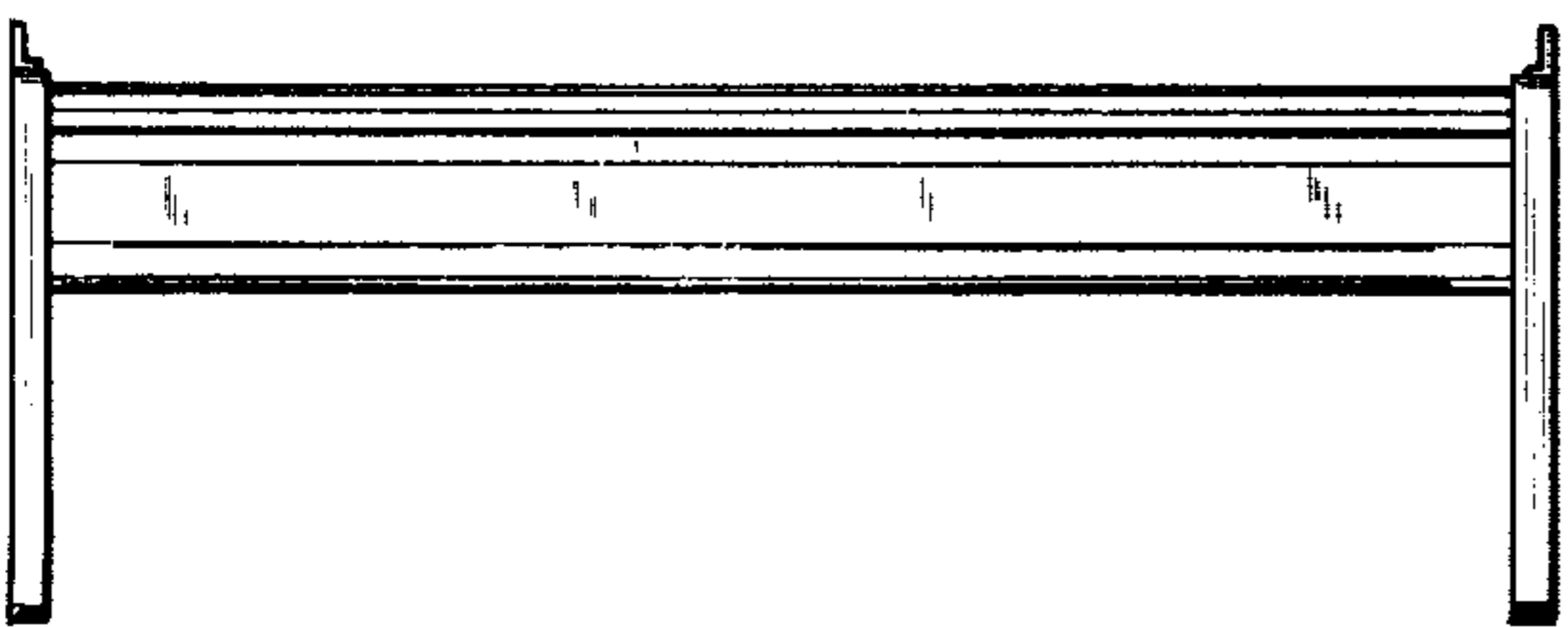

FIG. 5

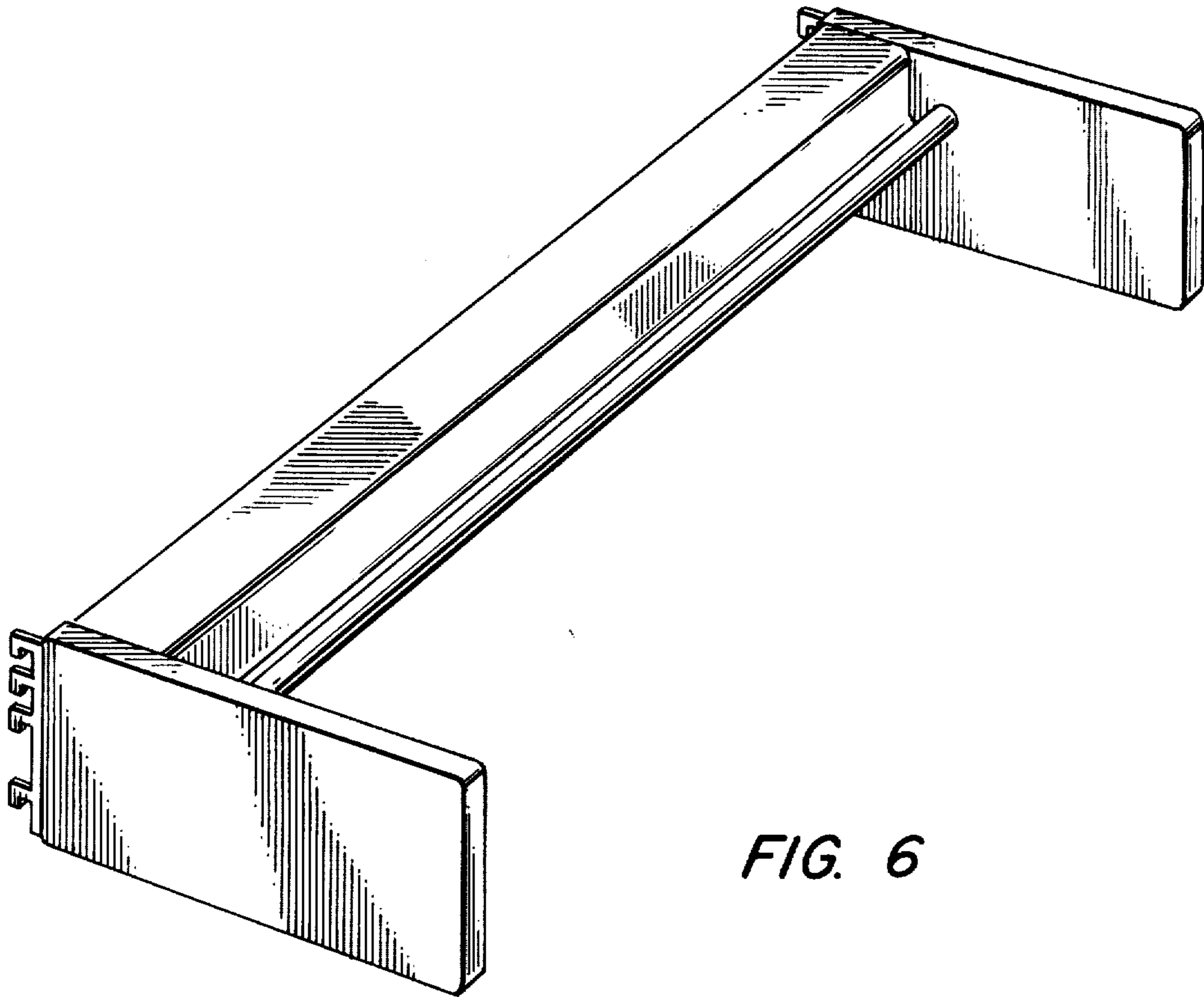

FIG. 6