

[54] **MOTORCYCLE**

[75] **Inventor:** Shinji Iwasaki, Tokyo, Japan

[73] **Assignee:** Yamaha Hatsudoki Kabushiki Kaisha,
Japan

[**] **Term:** 14 Years

[21] **Appl. No.:** 232,402

[22] **Filed:** Feb. 6, 1981

[30] **Foreign Application Priority Data**

Aug. 9, 1980 [JP] Japan 55-32660

[51] **Int. Cl.** D12-11

[52] **U.S. Cl.** D12/110

[58] **Field of Search** D12/110; 180/219

[56] **References Cited**
PUBLICATIONS

Cycle World, 2/79, p. 57, Honda CB650.
Cycle World, 2/79, p. 86, Kawasaki LTD400.
Cycle World, 6/80, p. 74, Yamaha 1979 XS650F, top of page.

Primary Examiner—James M. Gandy
Attorney, Agent, or Firm—Ostrolenk, Faber, Gerb & Soffen

[57] **CLAIM**

The ornamental design for a motorcycle, as shown.

DESCRIPTION

FIG. 1 is a perspective view of a motorcycle showing my new design;

FIG. 2 is a left side elevational view thereof;

FIG. 3 is a front elevational view thereof;

FIG. 4 is a rear elevational view thereof;

FIG. 5 is a right side elevational view thereof; and

FIG. 6 is a top plan view thereof.

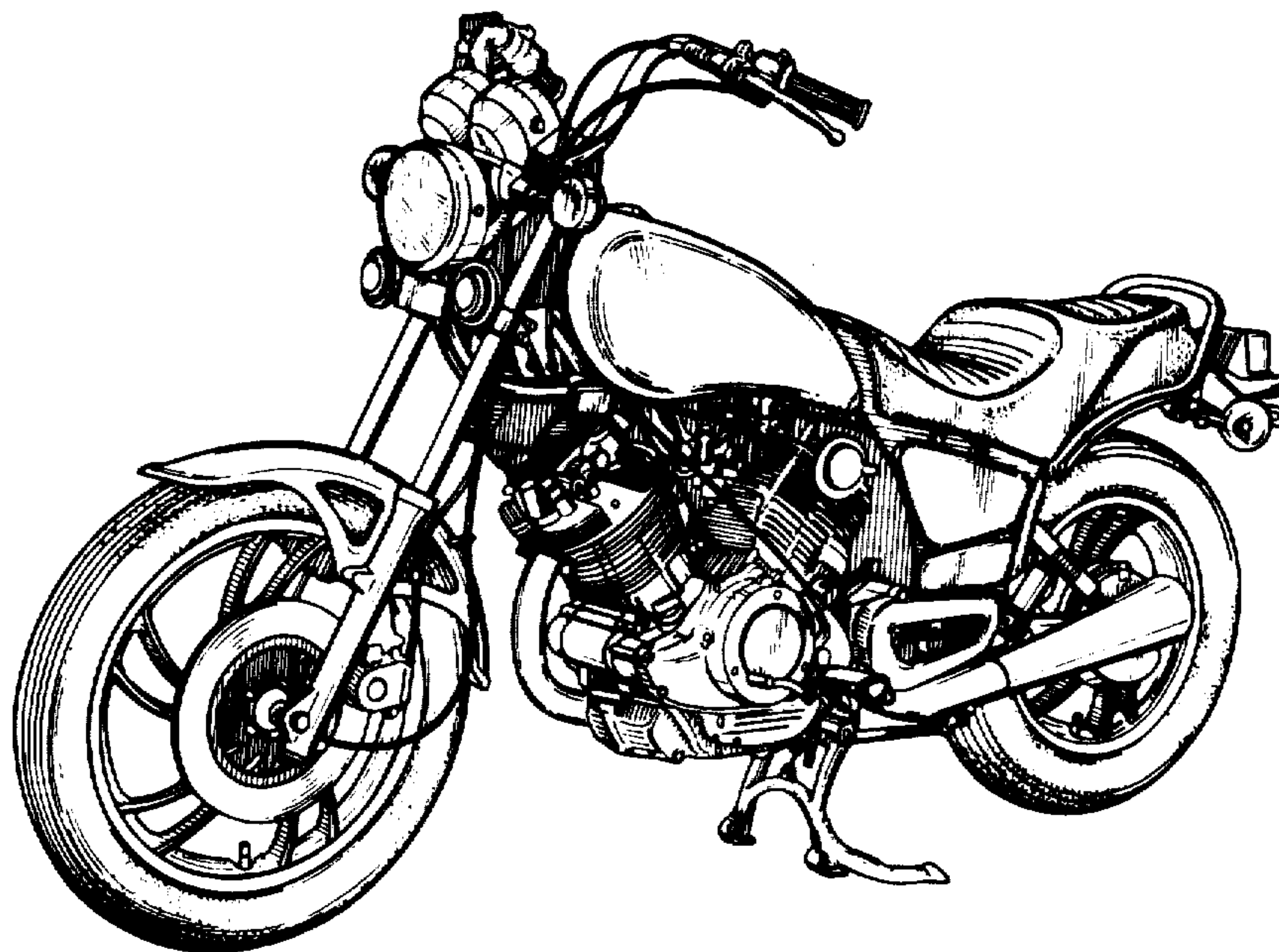

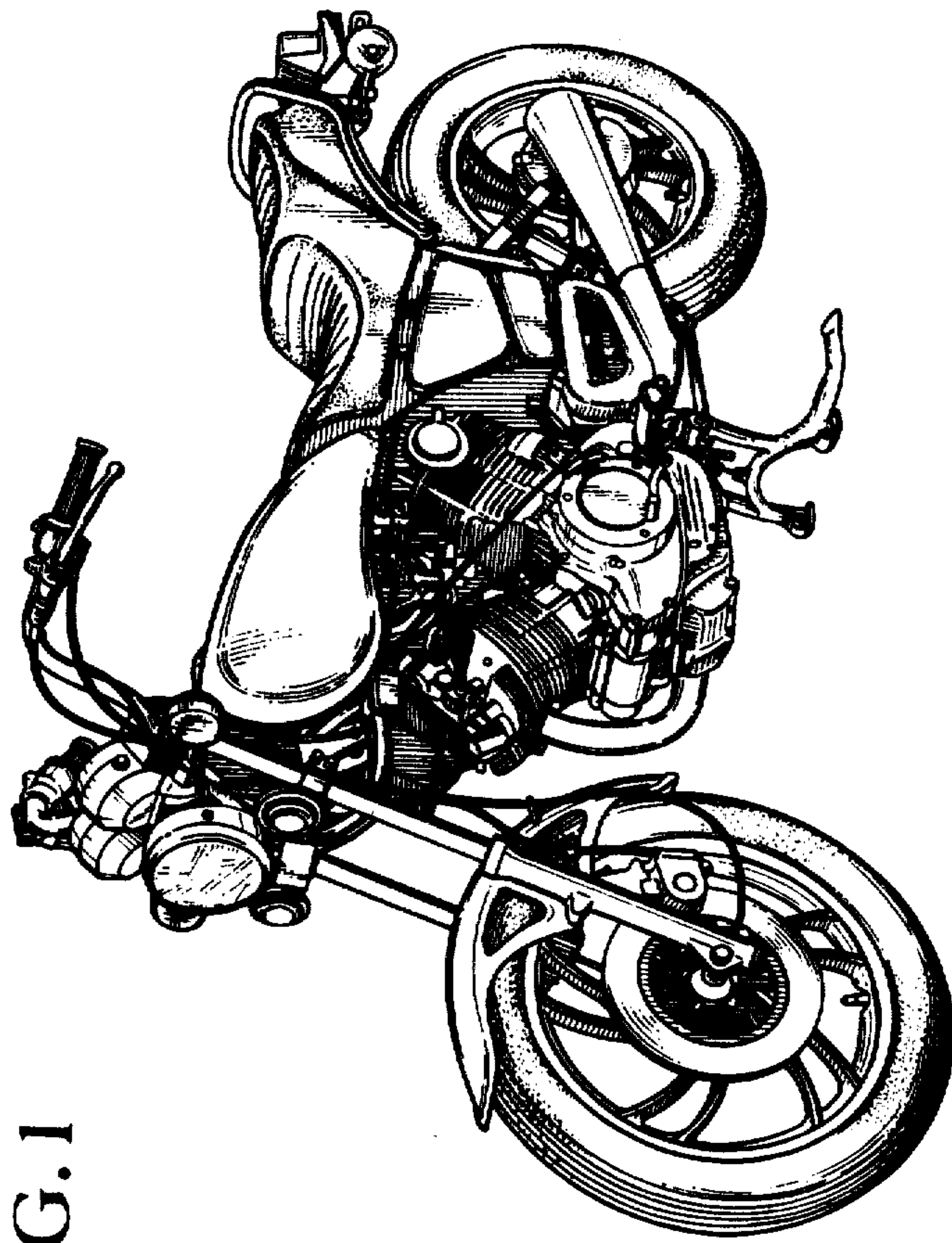

FIG. 1

FIG.2

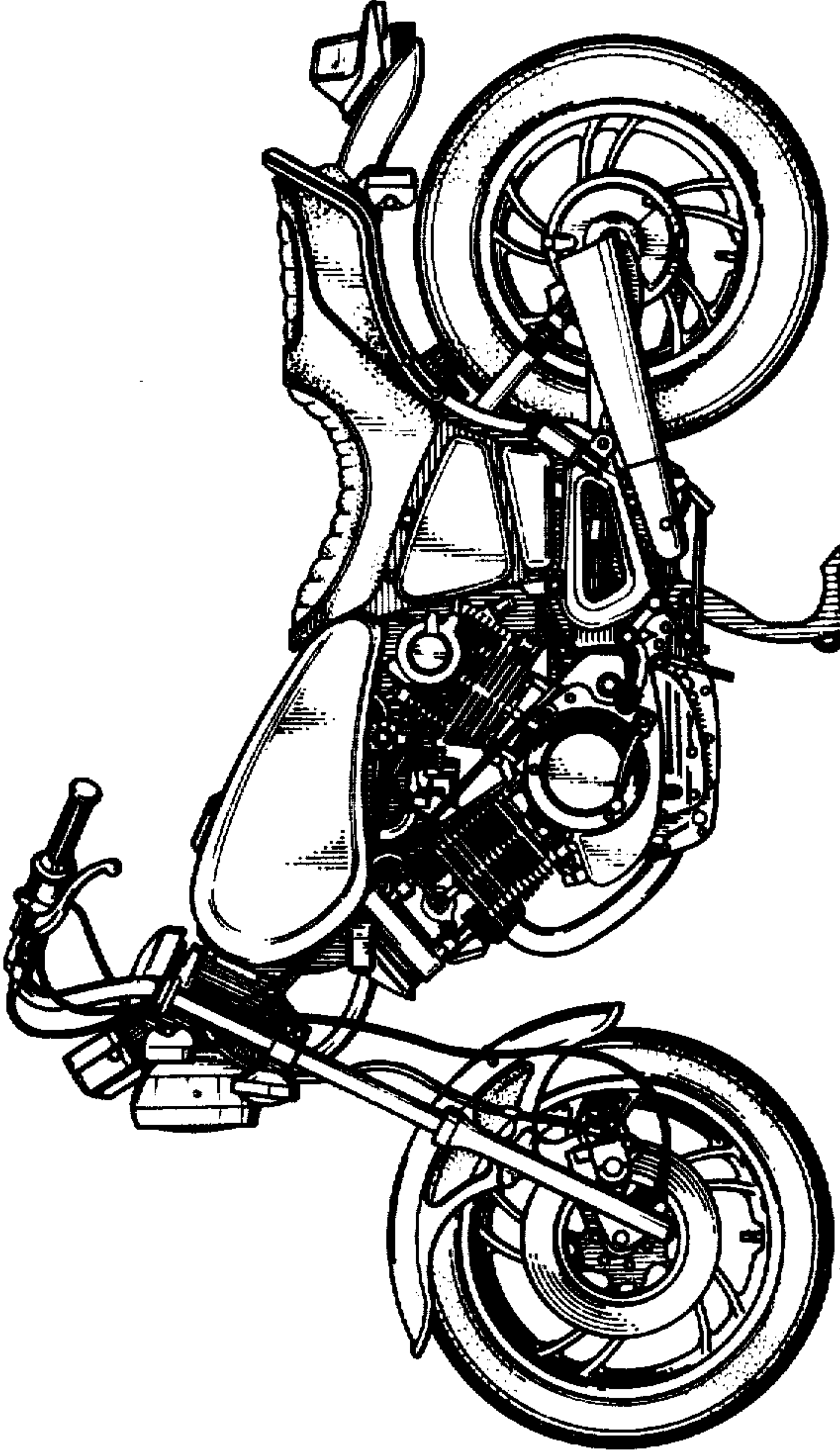

FIG.4

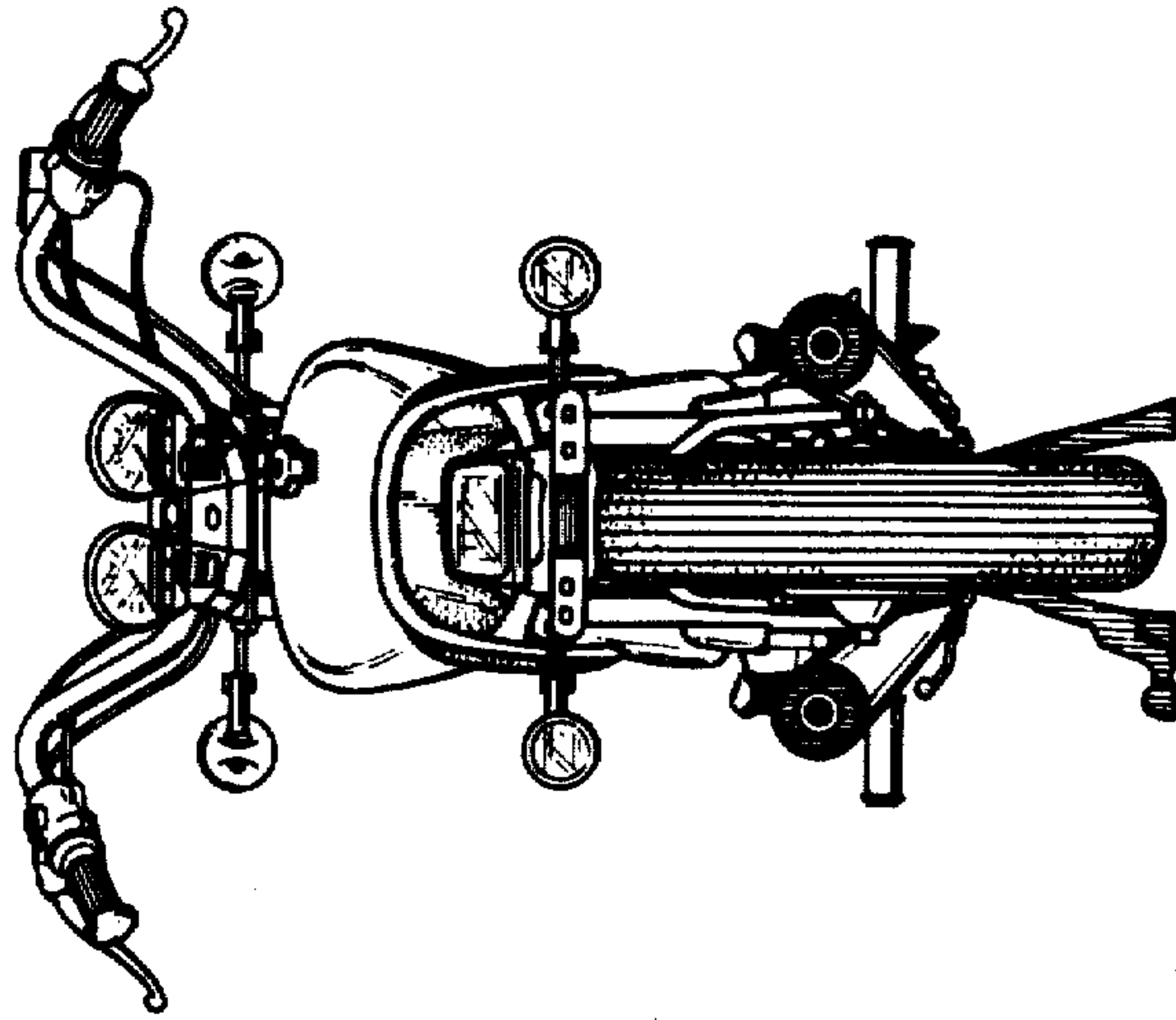

FIG.3

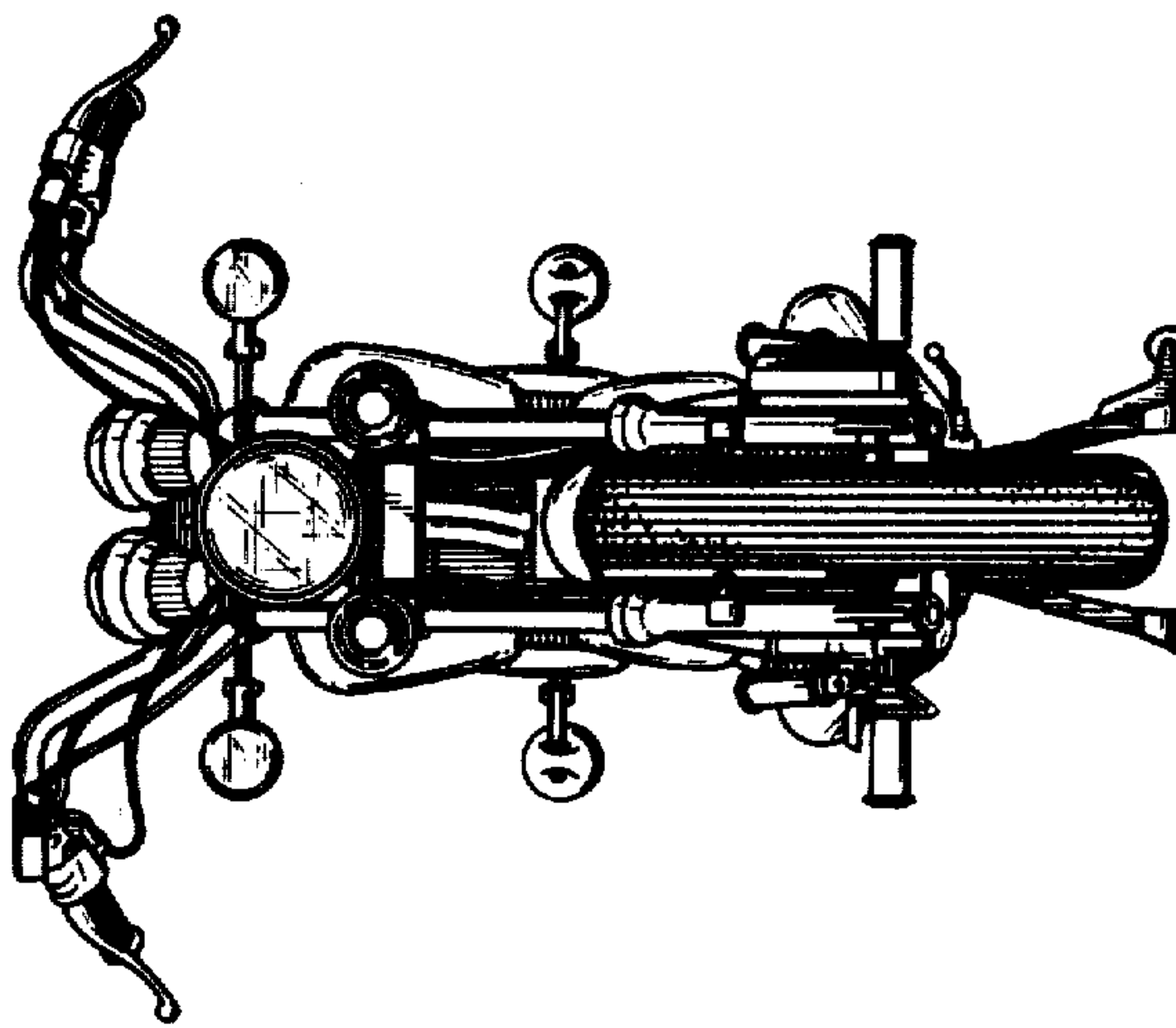

FIG.5

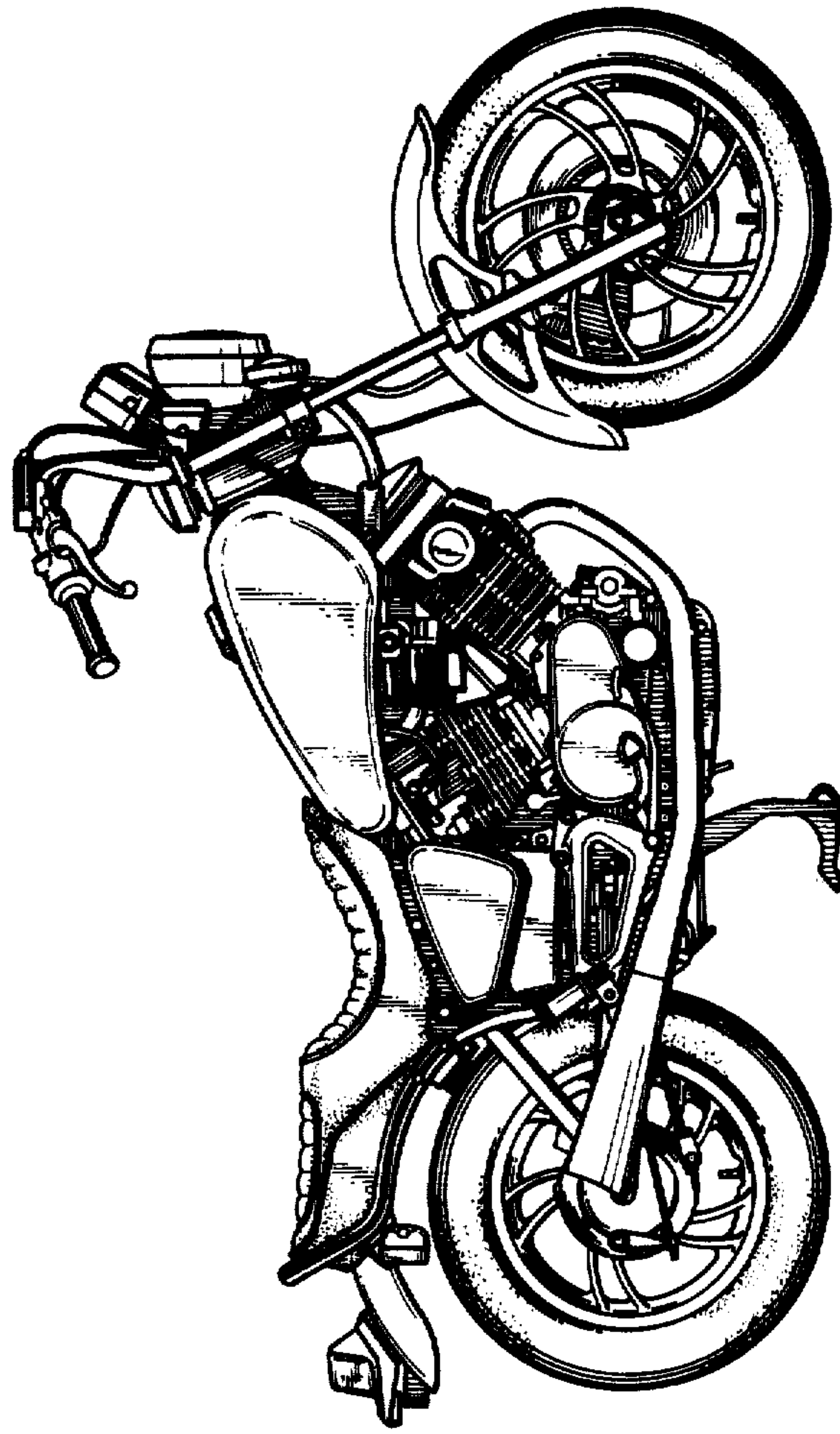

FIG.6

